



EUROfusion

WPRM-CPR(18) 20239

S Budden et al.

Rescue and recovery studies for the DEMO Blanket Transporter

Preprint of Paper to be submitted for publication in Proceeding of
30th Symposium on Fusion Technology (SOFT)



This work has been carried out within the framework of the EUROfusion Consortium and has received funding from the Euratom research and training programme 2014-2018 under grant agreement No 633053. The views and opinions expressed herein do not necessarily reflect those of the European Commission.

This document is intended for publication in the open literature. It is made available on the clear understanding that it may not be further circulated and extracts or references may not be published prior to publication of the original when applicable, or without the consent of the Publications Officer, EUROfusion Programme Management Unit, Culham Science Centre, Abingdon, Oxon, OX14 3DB, UK or e-mail Publications.Officer@euro-fusion.org

Enquiries about Copyright and reproduction should be addressed to the Publications Officer, EUROfusion Programme Management Unit, Culham Science Centre, Abingdon, Oxon, OX14 3DB, UK or e-mail Publications.Officer@euro-fusion.org

The contents of this preprint and all other EUROfusion Preprints, Reports and Conference Papers are available to view online free at <http://www.euro-fusionscipub.org>. This site has full search facilities and e-mail alert options. In the JET specific papers the diagrams contained within the PDFs on this site are hyperlinked

Rescue and recovery studies for the DEMO Blanket Transporter

Stuart Budden¹, Victor Agudo¹, Ane Barturen¹, Luis Hannoun¹, Jonathan Keep¹, Antony Loving¹, Paul Shaughnessy², Gregory Keech³

¹Remote Applications in Challenging Environments (RACE), UKAEA, Culham Science Centre, Abingdon, Oxfordshire, OX14 3DB, United Kingdom

²AREVA RMC, 305 Bridgewater Place, Birchwood Park, Warrington, Cheshire, WA3 6XF, United Kingdom,

³EUROfusion Consortium, Boltzmannstr.2, Garching 85748, Germany

RACE has been developing a Blanket Transporter concept for the replacement of tritium breeding blankets within the EUROfusion DEMO tokamak. This operation will be challenging due to the scale of the blankets (~10m & 80 tonnes) and the current vessel design, which necessitates complex blanket kinematics within the vessel prior to a high vertical lift through the upper port. The blanket transporter is a key high technical risk system and break-down rescue and recovery has been highlighted as a significant unaddressed risk. This paper outlines the processes used to identify the key hazards resulting from failure scenarios and the improvements made to the concept design to mitigate them. Failure modes were identified via industrial expert input, failure and hazard analyses. Mitigation of the failure scenarios was achieved by providing secondary load paths in the main structure, redundancy in key components and the inclusion of additional features that allowed secondary rescue equipment to engage to assist rescue.

Keywords: DEMO, remote maintenance, blanket transporter, rescue & recovery, complexity

1. Introduction

A key requirement of a viable Fusion power station is the reliable production and supply of electricity to the grid. To achieve this, stoppages for maintenance and breakdowns must be kept to a minimum. RACE has been developing a concept design for the Remote Maintenance (RM) system for the EUROfusion demonstration powerplant (DEMO). Within the DEMO tokamak, tritium breeding blankets will require periodic replacement via the upper vertical ports at the top of the vacuum vessel – see Fig. 1. This operation will be challenging due to the scale of the blankets (~10m tall, up to 80 tonnes) and the kinematics required to remove the blankets.



Fig. 1. Section through the 2017 EU DEMO configuration showing the Blanket Transporter removing a blanket.

The blanket transporter concept has been developed and has been previously presented as a key high technical risk system for the blanket replacement process [1]. Several independent industrial experts have reviewed the concept and highlighted break-down rescue and recovery as significant unaddressed risk. This paper outlines the processes used to identify the key hazards resulting from failure scenarios and the improvements made to the concept design to mitigate them.

2. DEMO Blanket transporter

2.1 Hybrid kinematic mechanism

The blanket transporter concept is a hybrid kinematic mechanism with an integrated base plate that rigidly mounts on to the vacuum vessel port and provides 6-DoF at the blanket interface – see Fig. 2. The upper half consists of three leadscrew linear actuators creating a 3-DoF parallel mechanism. Mounted below is a serial mechanism comprising of three rotational axis joints. The blanket transporter is ~10m in height with a mass of ~70t.

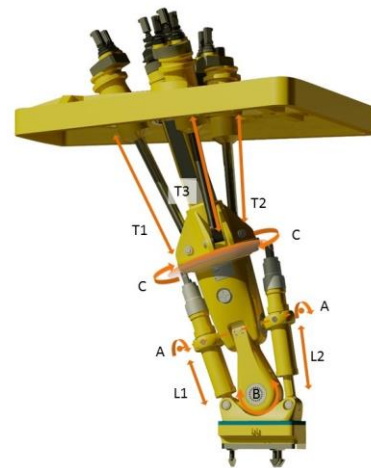

Fig. 2. DEMO Blanket transporter with joint identification

2.2 Key features in current design

The drivetrains (motor, gearbox, clutch and brake) for the parallel mechanism (actuators T1-T3) and rotational joint C are all positioned above the VV interface plate, meaning they are easily accessible from the port above. The drivetrains are modularized, having a single housing that contains all the required components, minimizing the number operations RM will have to perform. The drivetrains also have the capability to be operated by an external drive – for the instance where continuing operation is more economic than immediate repair.

Actuated joints A & B are situated below the VV interface plate, which has openings that would be suitable for access of a dexterous manipulator. The smallest opening is currently 740 x 800mm (for reference the port opening used for the MASCOT boom used on JET [2] is 1200x400mm). The current design for both joints A & B again utilizes modular units to simplify and speed up replacement and are designed to be RM compatible.

3. Rescue & Recovery process

3.1 Method

The following method, as displayed in Fig. 3, was utilized to review the blanket transporter concept, identify failure modes and formulate possible solutions.

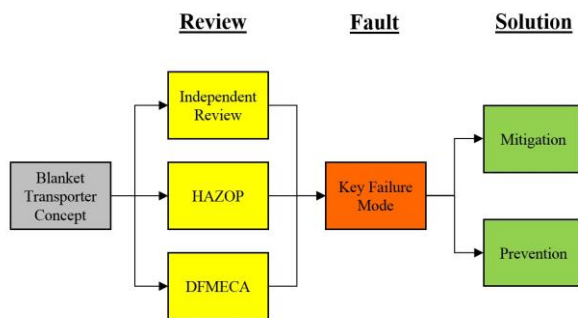

Fig. 3. Rescue & recovery process flow diagram

3.2 Input sources

The blanket transporter concept was independently reviewed by several industrial experts [3-5] to gain an impartial and original assessment of the concept and highlight areas that had been overlooked. The reviewers reported concerns with specific aspects of the current concept design when subjected to several breakdown scenarios. To consolidate these findings a hazard and operability study (HAZOP) was conducted under a further independent review [6]. The key hazards were identified and a range of engineering recommendations to mitigate them were specified. These included improved verification that a process or function had been successfully completed, additional redundancy in the design, the need for further testing to substantiate key components and further consideration of recovery from fault scenarios.

A Design, Failure mode, Effects and Criticality analysis (DFMECA) was performed [7] which systematically reviewed each component within the blanket transporter and assessed failure modes identified

in the HAZOP, probable effects of failure and the likelihood of occurrence.

Reviewing all the above studies lead to consolidation of the fault scenarios into four groups:

1. Prevention of / mitigating the consequences of a dropped load scenario
2. Safe release of the load during a fault scenario
3. A fault that during normal operations results in the locking/seizing (i.e. no movement) of each joint.
4. A fault that during normal operations results in the releasing/freeing (i.e. limp/loose) of each joint.

In addition, the following points required addressing:

5. Incomplete twistlock operation i.e. half open / half closed
6. Continuation of operations when a Blanket becomes stuck/jammed/wedged during the removal process

3.3 Fault scenarios

An Analytic Hierarchical Process was used to create a prioritized list of key failure scenarios, comparing the likelihood and severity of each.

Table 1. Prioritized fault scenarios.

Ranking	Title	%
1	Prevent Dropped Load	24.8
2	T1-T3: Seized	17.2
3	Twist-lock: Unknown status	12.2
4	Safely release the Blanket	9.7
5	Joint A: Seized	6.9
6	Joint C: Free	6.6
7	Joint A: Free	4.9
8	Joint B: Seized	4.2
9	T1-T3: Free	3.8
10	Jammed Blanket	3.6
11	Joint C: Seized	2.9
12	Joint B: Free	2.9

3.4 Possible solutions

Each of the fault scenarios was investigated and possible solutions identified. A standard method was followed for each scenario:

- Identification of component failure that results in the fault scenario (based on HAZOP [6] or DFMECA [7] data)
- Assessment of likelihood of component failure and difficulty of in-situ replacement
- Identification of mitigation strategies for fault

This paper focuses on the top two scenarios.

4 Dropped Load prevention/mitigation

A dropped load could have catastrophic consequences concerning both safety and asset protection and is therefore seen as the highest priority event to prevent/mitigate [8]. Removing large, full height,

segments of the blanket via a vertical lift (solely from above), requiring a lift height in excess of 10m, will result in a potential for significant damage, including breach of containment, in the event of a dropped load. Regulatory authorities will require robust evidence that a safety event, such as breaking of confinement cannot occur. Therefore, mitigation against a dropped load event; considering the frequency of the lifting operations, would have to be on a deterministic rather than probabilistic basis. [3]

Several failure modes have been identified that result in a dropped load [6] such as:

- Load Path Failure
- Early release of load resulting from spurious feedback to the control system
- Snagging and disengagement on adjacent equipment i.e. cooling pipes that have not been cut as specified

Two areas for investigation were identified concerning the dropped load fault scenario:

1. Prevention: introduction of a secondary load path
2. Mitigation: reduced dropping height

4.1 Prevention: Secondary load path

A dropped load can occur if there is a catastrophic failure of any key item within the load path between the upper port of the vacuum vessel and the blanket – see Fig. 3. [6, 7]. The load path includes components such as the upper gimbals, upper lead screws, slew bearing, blanket interface plate and twistlocks. The initial design proposed to mitigate this fault by utilizing an over-engineered design approach (incorporation of significant load factor) of the primary load path. Due to the space requirements and constraints of the problem achieving the required load factor was challenging and not possible in all parts of the path. In addition, this approach may not be deemed acceptable by the regulator, dependent on the safety implications. Often a deterministic view is applied where if it is possible for a component to fail at some point it is assumed it will.

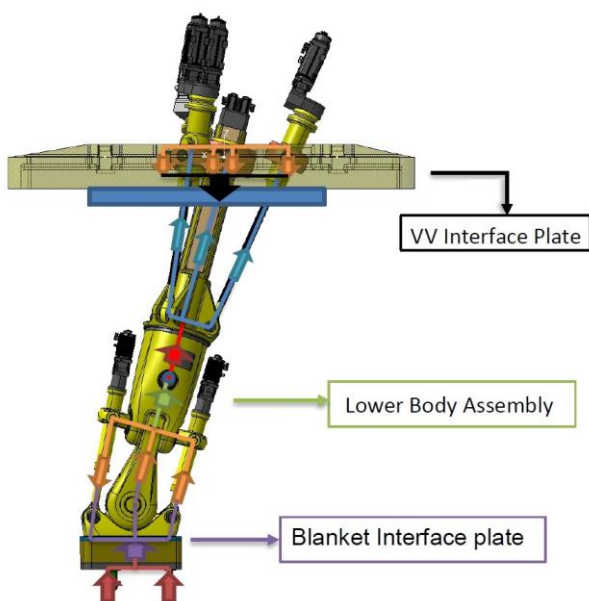

Fig. 3. DEMO Blanket transporter load path [6]

An alternative approach to mitigate this issue is to incorporate a secondary load path in the design. A secondary load path can be incorporated by including load arrestors between the VV interface plate and blanket interface plate. Load arrestors are an effective system for automatically halting the descent of released loads if the primary support system fails, such as the Neofeu NCHL Series Load Arrestors [9]. Three load arrestors would be incorporated in the solution, each one effectively acting as a substitute for each of the upper lead screws. Static analysis determined the peak tensile load in an upper lead screw as $\sim 1,550\text{kN}$ ($\sim 160\text{t}$) in the worst-case orientation. Currently COTS are not available at such capacities, therefore bespoke units would have to be commissioned.

A variation of this option would be to utilize a driven winch reel system instead of automatically activating load arrestors. This may be able to replicate many of the blanket transporter blanket manipulations by adjusting the length of the connecting cables. Inevitably this would result in a more complex solution and again suitable COTS are not available for the load capacity and size required.

4.2 Mitigation: Reduce dropping height

The consequences of a dropped load are directly related to the mass and height of the lift involved. The mass of the blanket is fixed within the current design requirements, but methods of reducing the drop height are available.

The drop height can also be separated into two zones:

1. In-vessel maneuvering
2. Vertical crane lift (in vertical shaft above vessel)

4.2.1 In-vessel maneuvering

During blanket transporter in-vessel blanket maneuvers, the blanket remains relatively low within the vessel (raised less than 3m), with the primary purpose being to position the blanket to enable the crane vertical lift phase. Due to this the potential energy, and hence potential damage caused by a dropped load is limited.

A proposed mitigation method is to deploy a raising platform mechanism through either the divertor or equatorial ports that would catch a dropped load. The mechanism will be telescopic and follow the blanket as it is raised, keeping the drop height to a minimum. A Serapid ChainLift telescopic actuator [10] may be a suitable technology to use for the raising mechanism as high lifting capacities can be attained in a compact deployment volume.

4.2.2 Vertical crane lift

During the crane lift, initially the blanket remains within the vessel, therefore the raising platform solution would be employed. Once clear of the vessel a robust hinged port lid could be activated and closed. This would provide some protection to the vessel and equipment below should a load be dropped, but as the lift progresses the dropping height and the potential for significant structural damage increases. A proposed solution is to widen the vertical shaft, allowing the crane to traverse

once the blanket is clear of the vessel vertical port. This would permit the vertical lift to be performed away from the vessel opening resulting in a dropped load not striking the vessel. If there is sufficient space, the new lifting zone could also contain a telescopic platform which would follow the remainder of the vertical lift, otherwise a crash structure could be included to absorb the impact forces of a dropped load. This solution would require extensive redesign of the surrounding area of the tokamak.

5 Actuators T1-T3: Seized

If one of the upper actuators became seized and therefore inactive the blanket transporter is unlikely to be able to continue with normal blanket maneuvering operations. Activating the two remaining actuators will allow some maneuverability, pivoting around the central gimbal and the seized actuator. Therefore, operations may be able to continue with a reduction in range of motion enabling recovery.

The key system components that could lead to a seized T1-T3 actuator are listed in Table 2. Each component is assessed to determine the likelihood that it could be replaced in-situ and likelihood of the fault occurring using standard severity and occurrence scoring [11].

Table 2. Prioritized fault scenarios.

No.	Fault	Remotely fixed/replaced	Likelihood of fault	Outcome
1	Motor inactive	Probably - modular unit accessible from above	High	OK
2	Jammed gearbox	Probably - modular unit accessible from above	Low	OK
3	Faulty brake	Probably - modular unit accessible from above	High	OK
4	Jammed Lead Screw	Unlikely	Low	Low Fail

The actuator drive train (motor, gearbox, brake, clutch) are located above the VV interface plate and are therefore easier to access to replace the modular unit. A seized lead screw is unlikely to be replaced in situ due to the size of the unit and complexity of integration.

There are two proposed solutions to mitigate this fault, depending on the source of the seizure. For loss of drive a remote tool could be deployed to operate the built-in external drive. Otherwise a temporary brace would be installed between the VV interface plate and the upper body shaft. This locks the upper parallel mechanism (joints T1-T3) allowing removal and replacement of key components via a dexterous manipulator without risk of movement of the transporter or blanket.

6 Conclusions

The current vessel design necessitates a high vertical lift, with little geometric scope for safe stopping points. Mitigating the dropped load scenario is imperative to gaining nuclear regulatory approval, as highlighted by several independent industrial reviews. Implementation of the load arrestor concept is a high-level priority if the blanket transporter concept is to be further developed. This solution provides a secondary load path between the VV interface plate and the blanket which mitigates a catastrophic mechanical failure in numerous blanket

transporter components. In addition, the system could be developed to aid in the event of other component failures (i.e. drivetrains) by allowing limited manipulation of the blanket to assist recovery. This method mitigates the failure, but further work is needed to demonstrate it is possible to rescue or recover fully from this state and return to normal operations.

Rescue and recovery solutions will add further complexity to an already novel blanket transporter concept, further challenging the reliability of the system. Due to the space restrictions and high structural loads specifying suitable COTS is challenging and, in many cases a bespoke solution is the only option, which inevitably increases the total cost and further impacts reliability and repeatability. Therefore, extensive physical testing will be vital for this novel and complex system, to reduce or eliminate design, manufacturing, assembly, maintenance and operating failures.

At the pre-concept stage a key aim of plant design must be to ensure plant layout permits maintenance operations to be performed as simply as possible, which leads to less complex systems and greater reliability and overall availability.

Acknowledgments

This work has been carried out within the framework of the EUROfusion Consortium and has received funding from the Euratom research and training programme 2014-2018 under grant agreement No 633053. The views and opinions expressed herein do not necessarily reflect those of the European Commission. We would also like to thank AREVA (Orano) and Nuvia Ltd for their contribution to this work.

References

- [1] J. Keep, Remote handling of DEMO breeder blanket segments: Blanket transporter conceptual studies, SOFT 2016
- [2] O. David et. al, Operational Experience Feedback in JET Remote handling, Fusion Engineering and Design Vol 75-79, Nov 2005, P519-523
- [3] Assystem Ltd, Assystem Industrial Review Report, EUROfusion 2016 - 2MMCQH
- [4] Nuvia Ltd, Nuvia Industrial Review, EUROfusion 2016 - 2N7SRZ
- [5] AREVA, AREVA Industrial Review, EUROfusion 2017 - 2MZJ2V
- [6] AREVA, AREVA Blanket Transporter Safety Justification Report, EUROfusion 2017 - 2N62JJ
- [7] L. Hannoun, Blanket transporter DFMECA, EUROfusion 2018 - 2NEG4B
- [8] D. Perrault, Safety issues to be taken into account in designing future nuclear fusion facilities, Fusion Engineering and Design, 109-111 (2016)
- [9] Neofeu NCHL Series Load Arrestors - www.neofeu.com
- [10] Serapid Chainlift Lifting Chain - www.serapid.com
- [11] D. v. Houtte, K. Okayama and F. Sagot, "ITER RAMI Analysis Program," ITER, 2012