



EUROfusion

WPPMI-CPR(17) 16953

R. Zanino et al.

**Benchmark of the GETTHEM Vacuum
Vessel Pressure Suppression System
(VVPSS) model for a? helium-cooled EU
DEMO blanket**

Preprint of Paper to be submitted for publication in Proceeding of
27th European Safety and Reliability Conference (ESREL 2017)



This work has been carried out within the framework of the EUROfusion Consortium and has received funding from the Euratom research and training programme 2014-2018 under grant agreement No 633053. The views and opinions expressed herein do not necessarily reflect those of the European Commission.

This document is intended for publication in the open literature. It is made available on the clear understanding that it may not be further circulated and extracts or references may not be published prior to publication of the original when applicable, or without the consent of the Publications Officer, EUROfusion Programme Management Unit, Culham Science Centre, Abingdon, Oxon, OX14 3DB, UK or e-mail Publications.Officer@euro-fusion.org

Enquiries about Copyright and reproduction should be addressed to the Publications Officer, EUROfusion Programme Management Unit, Culham Science Centre, Abingdon, Oxon, OX14 3DB, UK or e-mail Publications.Officer@euro-fusion.org

The contents of this preprint and all other EUROfusion Preprints, Reports and Conference Papers are available to view online free at <http://www.euro-fusionscipub.org>. This site has full search facilities and e-mail alert options. In the JET specific papers the diagrams contained within the PDFs on this site are hyperlinked

Benchmark of the GETTHEM Vacuum Vessel Pressure Suppression System (VVPSS) model for a helium-cooled EU DEMO blanket

A. Froio, A. Bertinetti, L. Savoldi, R. Zanino
NEMO group, Dipartimento Energia, Politecnico di Torino

F. Cismondi, S. Ciattaglia
PPPT Department, EUROfusion Consortium

ABSTRACT: In the nuclear field, the correct evaluation of the effects of design-basis accidents is fundamental to correctly design the countermeasures needed to preserve the integrity of the containment barriers and to confine the radioactive material. Therefore, both in fission and in fusion, notwithstanding the different amounts of radioactive materials, the availability of models that can predict the accidental transients is crucial.

Here we describe the model recently developed to analyse an in-vessel Loss-Of-Coolant-Accident in the EU DEMO fusion reactor, and implemented in the GETTHEM code. In particular, we focus on the release of coolant inside the Vacuum Vessel (VV) following a break in the breeding blanket cooling loop, considering a helium-cooled blanket solution. The model of the VV pressure suppression system is calibrated and benchmarked exploiting results from the validated CONSEN code by ENEA.

NOMENCLATURE

Symbol	Variable	SI Unit
m	Mass	kg
\dot{m}	Mass flow rate	kg/s
V	Volume	m ³
ρ	Density	kg/m ³
t	Time	s
E	Energy	J
\dot{Q}_{ext}	Thermal power	J
u	Specific internal energy	J/kg
h	Specific enthalpy	J/kg
p	Pressure	Pa
T	Temperature	K
R^*	Gas constant	J/(kg K)
c_v	Specific heat at constant volume	J/(kg K)
K	Localized pressure loss coefficient	-
F_k	Ratio of specific heats factor	-
x	Ratio of pressure drop to absolute inlet pressure	-
x_T	Terminal pressure drop ratio	-
Y	Compressibility factor	-

Horizon 2020 EU fusion roadmap (Romanelli, et al., 2012), is expected to be the first fusion reactor to produce net electricity by the 50's.

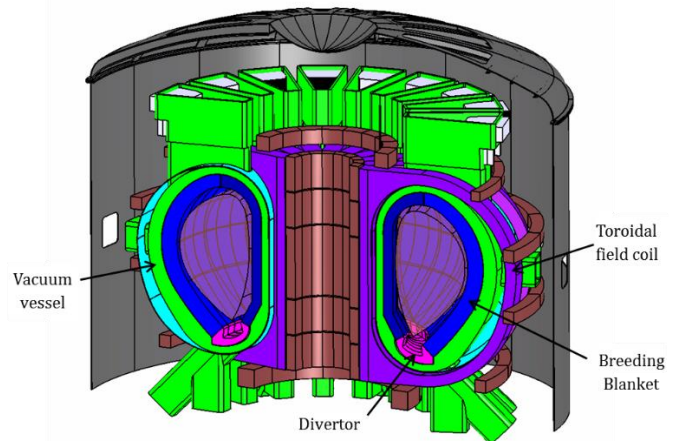

Figure 1: Sketch of the EU DEMO reactor.

1 INTRODUCTION

In the future, nuclear fusion could play a non-negligible role in electricity production, in view of the increasing demand of CO₂-free energy. The most important forthcoming fusion experiment will be the ITER tokamak, which is currently under construction in France.

Europe is proposing the European Demonstration Fusion Power Reactor (EU DEMO), see Figure 1, as the step next to ITER, which, as foreseen by the

One of the design-basis accidents (DBAs) foreseen for this kind of reactor is the in-vessel Loss-Of-Coolant Accident (LOCA) (Bachmann, Personal communication, 2016), occurring when the high-pressure coolant leaks from the Breeding Blanket (BB) or from the divertor into the Vacuum Vessel (VV), which must be kept at very low pressures (order of μPa) for the plasma operation; this may happen because of the melting of a portion of the First Wall (FW), which is the first component facing the plasma, caused by runaway electrons that can pro-

duce a large toroidal break in the FW (Maviglia, 2016). Consequently, if a rupture in the cooling system occurs, the VV experiences a rapid pressurization. To avoid the rupture of the VV, which is also the first containment barrier for the radioactive tritium contained in the plasma chamber, a Vacuum Vessel Pressure Suppression System (VVPSS) is to be designed, in line with ITER, which should accomplish the double action of preserving the integrity of the VV and of safely storing the coolant inventory.

During the last couple of years, a system-level code for the transient analysis of thermal-hydraulic transients in tokamak fusion reactors, called General Tokamak THERmal-hydraulic Model (GETTHEM), has been developed at Politecnico di Torino (Froio, et al., 2016; Froio, et al., in press). It is a fast-running tool able to evaluate the transient thermal-hydraulic behaviour of the tokamak Primary Heat Transfer System (PHTS) and Balance of Plant (BoP). GETTHEM is able to cope with either helium or water as coolant, and currently contains the model for the cooling loops of the Helium-Cooled Pebble Bed (HCPB) and Water-Cooled Lithium-Lead (WCLL) BB concepts. The tool is based on the Modelica language, which is an equation-based a-causal object-oriented modelling language aimed at simplified modelling of complex systems (Mattsson, et al., 1998; Fritzon, 2003).

This paper presents the simplified model developed for the EU DEMO VVPSS, for the case of a helium-cooled BB concept, and implemented in GETTHEM. The model calibration and benchmark

against the validated CONSEN code (Caruso, 1997) is also shown.

2 METHODOLOGY

The simplified layout of the VVPSS in the EU DEMO reactor, used for the definition of our model, is shown in Figure 2. It consists of the PHTS, that is the piping system in which the coolant flows inside the BB, the VV and an Expansion Volume (EV), used to safely store the coolant and to avoid overpressure, connected to the VV by means of one or more relief lines, equipped with Burst Disks (BDs). In addition to the relief lines, other, smaller lines, connecting the VV to the EV are available, equipped with valves, to be used in case of small leakages; these are called *bleed lines* (BLs). These smaller lines may intervene also in the case of larger leakages, as the large toroidal break considered as DBA, although their smaller cross section limits their effectiveness in the pressure mitigation. The BB is contained inside the VV. For the scope of this work, the VV is assumed to have a maximum design pressure of 0.2 MPa, in line with the ITER VV. The EV is a tank where the coolant shall be stored; in order to reduce the helium temperature (and, consequently, pressure), it might be partly filled with room-temperature water.

The DBA analysed here (an in-vessel LOCA) is assumed to occur due to the melting of a portion of the First Wall (FW), which is the first component facing the plasma and is thus actively cooled.

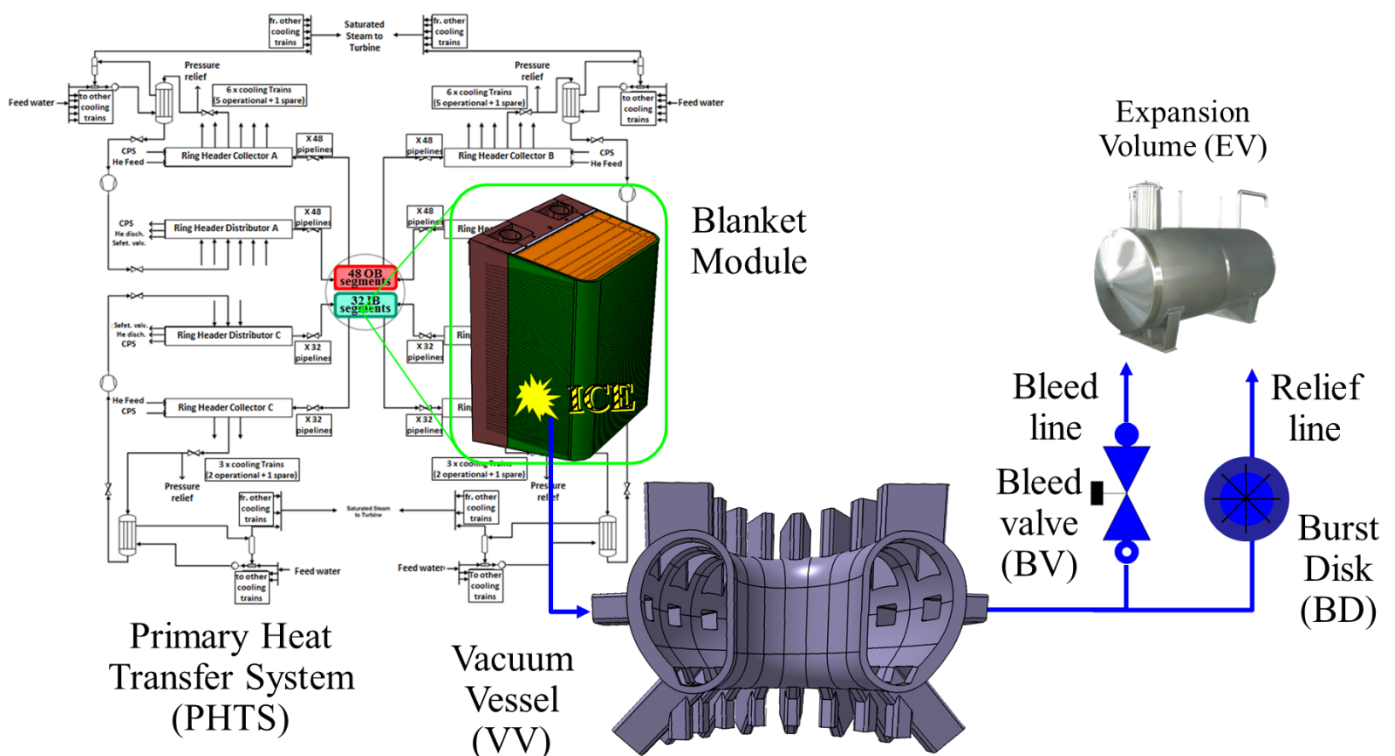

Figure 2: EU DEMO VVPSS system layout (adapted from Norajitra, et al., 2015; Hurlzmeier, et al., 2015).

When this break occurs, the helium coolant (nominally at 8 MPa) flows out of the FW into the plasma chamber, which is kept at very low pressures (at 5 μ Pa before the injection of the fuel) during tokamak operation.

This huge pressure difference will necessarily cause a choked flow between the FW and the VV, thus decoupling the cooling loop dynamics from the VVPSS dynamics. At this time, the pressure within the VV rapidly increases, as it gets filled by the He coolant; when the set-point differential pressure of the bleed valves (BVs) is reached the BVs open and the BLs start discharging the coolant inside the EV, albeit removing possibly only a small fraction of the coolant flow rate entering the VV (as their cross section is much smaller than the break size).

Since the BLs alone are not able to effectively reduce the pressure, at some time also the differential pressure causing the rupture of the burst disks is reached and a much larger flow rate of coolant starts to be discharged inside the EV. At this point, the evolution of the transient is largely affected by the ratio of the flow rates (incoming in the VV vs. outgoing to the EV), and, consequently, of the ratio of the cross sections of the break and the relief line: if the latter is large enough, the pressure in the VV starts decreasing immediately, while it continues increasing for a short time otherwise. Eventually, the pressure within the VV and EV reaches the same value.

2.1 Helium system model

Figure 3 shows the GETTHEM model of the EU DEMO VVPSS for the helium-cooled blanket. All the components are modelled with a 0D approach. Although the 1D model of the PHTS (already present in GETTHEM) might be used, the choice of a 0D model for the present analysis is justified considering the choked flow occurring at the break, which, by limiting the flow rate, makes the timescale rele-

vant for 1D localized effects in the PHTS much larger than the characteristic times of the transient. The 0D approach helps also in keeping the computational cost low.

The components relevant for the VVPSS analysis have been added to the GETTHEM library starting from components available in the publicly available validated ThermoPower Modelica Library (Casella, et al., 2003; Casella, et al., 2006). For the computation of the thermophysical properties of the coolant, the helium ideal gas model defined in the Modelica Standard Library is adopted.

The models of the relevant subsystems are described in the following sections.

2.2 PHTS, VV, and EV models

The PHTS, VV and EV are modelled as 0D constant volume tanks. In these models, conservation of mass (Equation 1) and energy (Equation 2) are imposed:

$$\frac{dm}{dt} = \sum \dot{m}_{in} - \sum \dot{m}_{out} = V \frac{d\rho}{dt} \quad (1)$$

$$\frac{dE}{dt} = \frac{\partial(mu)}{\partial t} = \sum \dot{m}_{in} h_{in} - \sum \dot{m}_{out} h_{out} + \dot{Q}_{ext} \quad (2)$$

where V is the volume, m and E are the total mass and energy inside the volume, $\dot{m}_{in/out}$ are the inlet/outlet mass flow rates, ρ is the helium density, u is the helium specific internal energy and $h_{in/out}$ are the helium specific enthalpies at inlet/outlet. The kinetic and potential energy terms at inlet/outlet are neglected, and the control volume is assumed to be fixed (*i.e.*, no potential and kinetic energy variation inside the control volumes are computed). Moreover, no mechanical organs are present and no phase change may happen, since the working fluid is a homogeneous gas.

The models include in principle the possibility to apply external thermal sources or sinks \dot{Q}_{ext} (positive

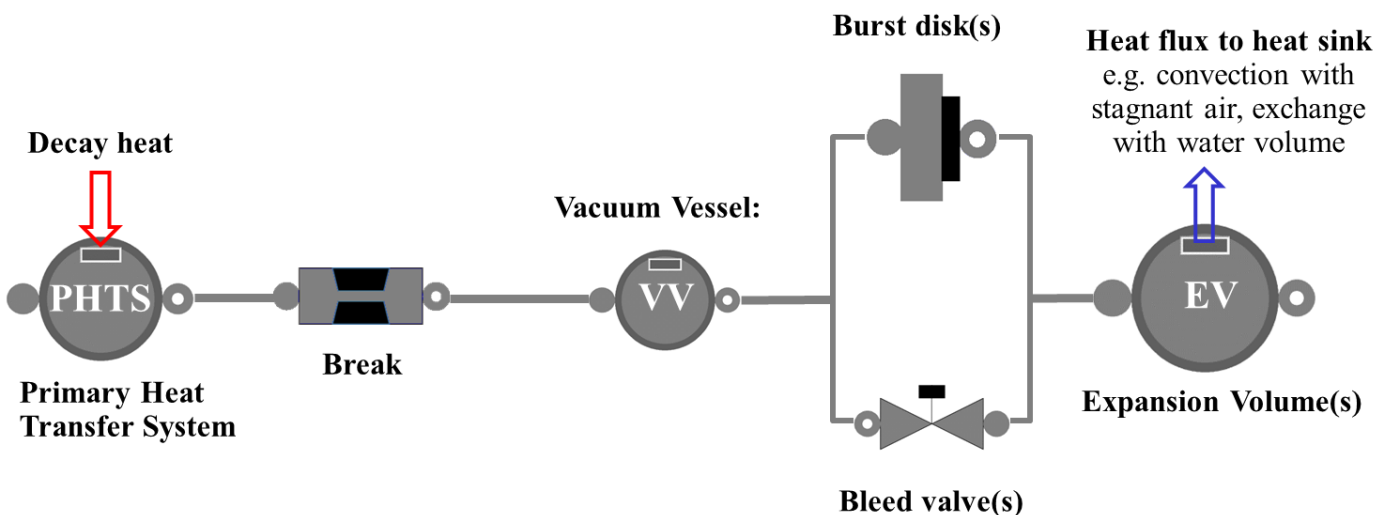

Figure 3: GETTHEM model of the EU DEMO VVPSS for helium coolant.

if heat is entering the volume) on all the components, which may represent, for instance, the decay heat deposition in the PHTS or the effect of any cooling strategies in the EV, such as the above-mentioned water mass or simply the natural convection heat transfer with the air outside the EV.

Note that the choice to use a 0D model also for the PHTS is justified by the decoupling of the PHTS dynamics from the VVPSS dynamics provided by the choked flow occurring at the break, as mentioned earlier.

2.3 Break model

The break in the FW is modelled as a 0D localized pressure loss, solving Equation 3:

$$\dot{m} = A\sqrt{K\rho\Delta p_{eff}} \quad (3)$$

where \dot{m} is the mass flow rate through the component, A is the break cross section, K is the localized pressure loss coefficient, ρ is the helium density and the effective pressure loss Δp_{eff} is computed in order to account for choked flow: if $p_{in}/p_{out} < (p_{in}/p_{out})_{crit}$ then $\Delta p_{eff} = p_{in} - p_{out}$, otherwise $\Delta p_{eff} = p_{in} - p_{in}/(p_{in}/p_{out})_{crit}$. The only input parameters for this model are A and K , while the critical pressure ratio $(p_{in}/p_{out})_{crit}$ is a characteristic of the fluid.

2.4 Burst disks and BV models

The burst disks and BVs are modelled as 0D valves (according to the ANSI/ISA-75.01 standard (ANSI/ISA, 2007)) that open when the pressure drop across the component is higher than a threshold value Δp_{thresh} , as described in Equation 4:

$$\dot{m} = \begin{cases} 0 & \text{until } \Delta p < \Delta p_{thresh} \\ AY\sqrt{K\rho x_{eff} p_{in}} & \text{when } \Delta p \geq \Delta p_{thresh} \end{cases} \quad (4)$$

where \dot{m} is the mass flow rate through the component, Δp_{thresh} , K (the localized pressure loss coefficient) and A (the cross section) are parameters which can be set independently for each instance¹ of the model, p_{in} is the pressure at inlet and the compressibility factor Y and the effective pressure drop ratio x_{eff} are determined according to Equations 5 and 6, respectively:

$$Y = 1 - \frac{|x_{eff}|}{3F_k x_T} \quad (5)$$

¹ In object-oriented programming, the word *instance* refers to each distinct use of an object.

$$x_{eff} = \begin{cases} \frac{\Delta p}{p_{in}} & \text{if } \frac{\Delta p}{p_{in}} < F_k x_T \\ F_k x_T & \text{if } \frac{\Delta p}{p_{in}} \geq F_k x_T \end{cases} \quad (6)$$

where the ratio of specific heats factor F_k is defined as $\gamma/1.4$ ($\gamma = c_p/c_v$ is the ratio of specific heats of the gas) and the terminal pressure drop ratio x_T is a parameter depending on the valve type. The product $F_k x_T$ is called *critical ratio at full opening*.

The valves are assumed to open instantaneously; after that, they remain open, even if the pressure drop falls again below the threshold.

3 MODEL CALIBRATION AND BENCHMARK

The model described in the previous section is calibrated and benchmarked here against the results obtained from the validated CONSEN code on the same system, described in (Caruso, 2016) and characterized by the parameter values in Table 1. In the referenced report, the large toroidal break previously described is assumed to happen in the EU DEMO tokamak, caused by the melting of 10 m² of FW and leading to the release of all the BB coolant inventory to the VV.

Two scenarios are selected and used here: the first one, which is considered as the reference case in the CONSEN analysis, is used to calibrate the $F_k x_T$ parameters in the burst disk and bleed valve models (see Equations 5 and 6) in order to match the CONSEN results; the second scenario is then used to benchmark the calibrated GETTHEM model under different conditions, keeping the calibration parameters frozen; in the second scenario, the number of BLs and relief lines, as well as their size, are different from the first scenario, as summarized in Table 2. All results from the CONSEN analyses reported in the following are taken from the figures in (Caruso, 2016).

Table 1: Value of the input parameters characterizing the circuit used in the CONSEN and GETTHEM analysis.

PHTS	
Volume [m ³]	2325
Initial pressure [MPa]	8
Initial temperature [°C]	673
Break	
Cross section [m ²]	0.2
Localized pressure loss coefficient	5
VV	
Volume [m ³]	2243
Initial pressure [μPa]	5
Burst disks	
Opening differential pressure* [MPa]	0.15
Localized pressure loss coefficient	3.5
Bleed valves	
Opening differential pressure* [MPa]	0.09
Localized pressure loss coefficient	3.5
EV	

Volume [m ³]	120000
Initial pressure [kPa]	4.2

* These values are assumed to be equal to the ITER VVPSS.

The main difference between the CONSEN model of the VVPSS and the GETTHEM one is the absence in the latter of the piping system in the relief lines; while these pipes can actually be modelled in GETTHEM, the results of the simulation performed including a 1D model of the pipes showed negligible differences, but consistently higher computational cost (due to the necessity to discretize the pipes with a moderate number of nodes) with respect to the simulation without the piping model. This is justified by the very high values of flow rate reached within the lines during most of the transient, which make the transit time inside these pipes much shorter than the characteristic times of the transient; the fluid volume within the pipes is included inside the OD components, although it is only a negligible fraction of the total volume (less than 3 % than the VV volume). Hence, the following results refer to the simulation performed with OD models only.

Table 2: Value of the parameters characterizing the calibration scenario and the benchmark scenario.

	Calibration scenario*	Benchmark scenario
BLs		
Number	2	1
Cross section [m ²]	0.1	1.5
Relief lines		
Number	1	1
Cross section [m ²]	1	6.5

* These values are assumed to be equal to the ITER VVPSS.

3.1 Calibration scenario

Figure 4 compares the evolution of the pressure inside the three considered volumes (PHTS, VV and EV) computed with GETTHEM and CONSEN. The PHTS pressure of course decreases with an exponential-like law, as the coolant gradually outflows towards the VV and EV; the coolant rapidly fills the VV volume, leading in a few seconds to the pressure peak (which is much higher than the VV pressure limit). When the peak is reached, the pressure difference between VV and EV is now high enough to effectively discharge the coolant from the VV, thus decreasing the pressure; the transient timescale becomes larger as the flow rates (from PHTS to VV and from VV to EV) reduce, since the pressure values are going to homogenize.

In this scenario, the F_{kXT} parameters of the burst disk and BVs GETTHEM models have been calibrated in order to reproduce as accurately as possible the CONSEN pressure evolution; consequently, the two models predict the same peak and steady-state VV pressure, with a difference at the peak below 0.2 %. In addition, the time when the peak is reached is correctly reproduced by GETTHEM. The transient

is predicted to be faster by GETTHEM, with an error on the timescale of the VV pressure decay smaller than 10 %. This underestimation has been shown not to be due to the missing piping model in GETTHEM, as simulations performed including the pipes reported the same results, and are due to the different models used for the burst disk, which is modelled as a valve + localised pressure drop in GETTHEM.

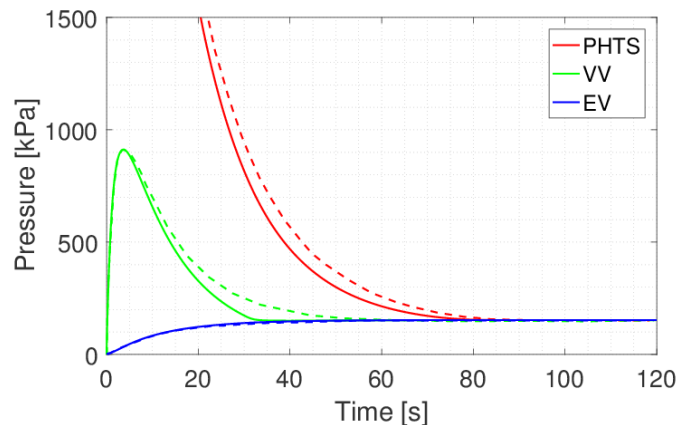

Figure 4: Evolution of the pressure in the three volumes of the VVPSS model (see Fig. 3) in the calibration scenario, for GETTHEM (solid lines) and CONSEN (dashed lines).

The temperature evolution computed by the two codes, as reported in Figure 5, is again very similar; this comes as a consequence of the good agreement obtained by calibration for the pressure, as temperature and pressure are tightly linked by the ideal gas law.

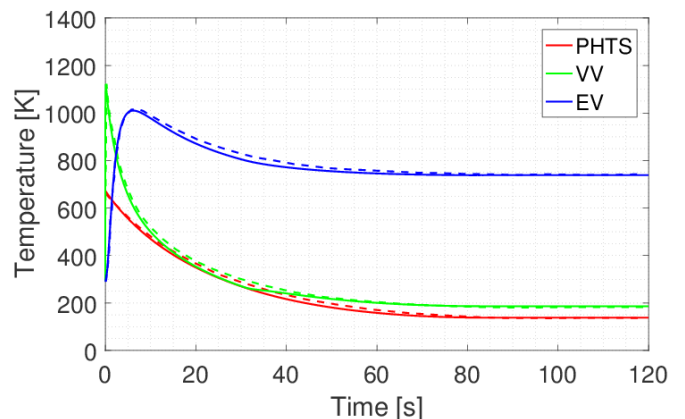

Figure 5: Evolution of the temperature in the three volumes of the VVPSS model (see Fig. 3) in the calibration scenario, computed by GETTHEM (solid lines) and CONSEN (dashed lines).

Of course, the three volumes reach three different values of temperature, as they have the same pressure but different volumes, thus reaching different temperatures as determined by the ideal gas law. The error on the timescale is propagated also to the tem-

perature evolution, but it is less evident when it comes to the transient duration, as the temperature-relevant timescales are much shorter than the pressure ones; in fact, the GETTHEM temperature evolution is almost overlapping with the CONSEN one.

3.2 Benchmark scenario

For the benchmark scenario, the burst disk and bleed valve models are maintained unchanged in GETTHEM with respect to the calibration scenario.

The variations in the system with respect to the previous scenario are related to the number of BLs and relief lines and to their cross sections, with the aim of decreasing the pressure peak in the VV. Table 2 shows the input parameters used in the benchmark process; these values have been chosen in order to limit the maximum pressure value inside the VV to the limit value of 200 kPa.

As already done for the previous scenario, the comparison between GETTHEM and CONSEN codes for the benchmark scenario are reported in terms of pressure (Figure 6) and temperature (Figure 7) in the PHTS, VV and EV components.

As expected, the maximum pressure value reached in the VV is 200 kPa at 1.2 s. The pressure undershoot in the VV after the peak is overestimated by the GETTHEM code in the period between ~ 5 s and ~ 20 s as a consequence of the underestimation of the VV pressure decay characteristic time already highlighted in the calibration scenario. The steady state pressure value in the VV, and in the other components which are in equilibrium, is ~ 150 kPa, well in agreement with the CONSEN results. The temperature evolution is similar with respect to the previous scenario, with slightly smaller peak values.

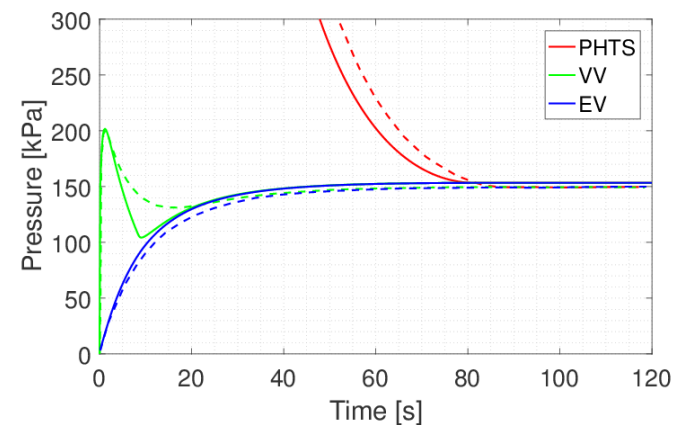

Figure 6: Evolution of the pressure in the three considered volumes for the benchmark scenario, computed by GETTHEM (solid lines) and CONSEN (dashed lines).

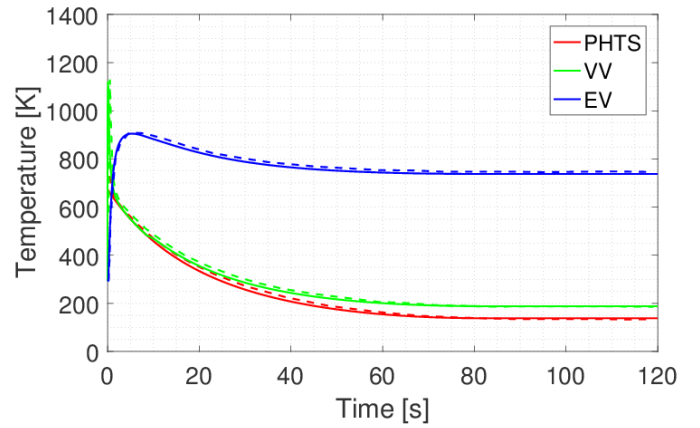

Figure 7: Evolution of the temperature in the three considered volumes for the benchmark scenario, for GETTHEM and CONSEN models (solid lines: GETTHEM; dashed lines: CONSEN).

The comparison of the results shows a good agreement of the pressure and temperature peak values, both within the 1 % of discrepancy if compared to CONSEN results. The timing of the pressure and temperature peaks in the VV are also well reproduced. The overall duration of the transient is slightly underestimated also in the benchmark scenario, with an error comparable with the calibration scenario (~ 2 %). This underestimation is again due to the different models adopted for the burst disk and BVs, leading in GETTHEM to an overestimation of the mass flow rate removed from the VV with respect to CONSEN, as also highlighted by Figure 8, where the evolution of the mass flow rates is compared for the two codes. The change in slope predicted by GETTHEM around 10 s in the flow rate going to the EV is due to the reduction of the pressure drop ratio between VV and EV, which drops below the F_{kxT} value, causing a discontinuity in the x_{eff} derivative (and, consequently, in the mass flow rate derivative, as per Equations 6 and 4, respectively).

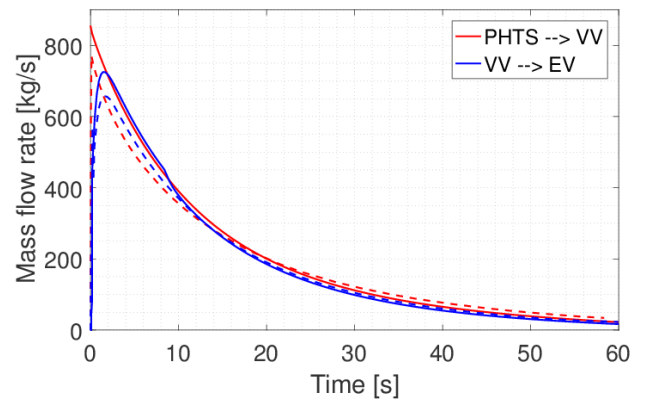

Figure 8: Evolution of the mass flow rate from PHTS to VV and from VV to EV, for the benchmark scenario, for GETTHEM and CONSEN models (solid lines: GETTHEM; dashed lines: CONSEN).

Figure 9 reports the evolution of the mass (a) and energy (b) stored within the three volumes; at the end of the transient, the vast majority (~96 %) of the overall system energy is stored within the EV, as its volume is much bigger than the other two; in fact, most of the system mass is stored inside this volume. During the transient, the evolution of mass and energy inside the VV follows the evolution of the pressure, thus increasing at the beginning but rapidly stabilizing, without ever storing more than a few percent of the total mass and energy.

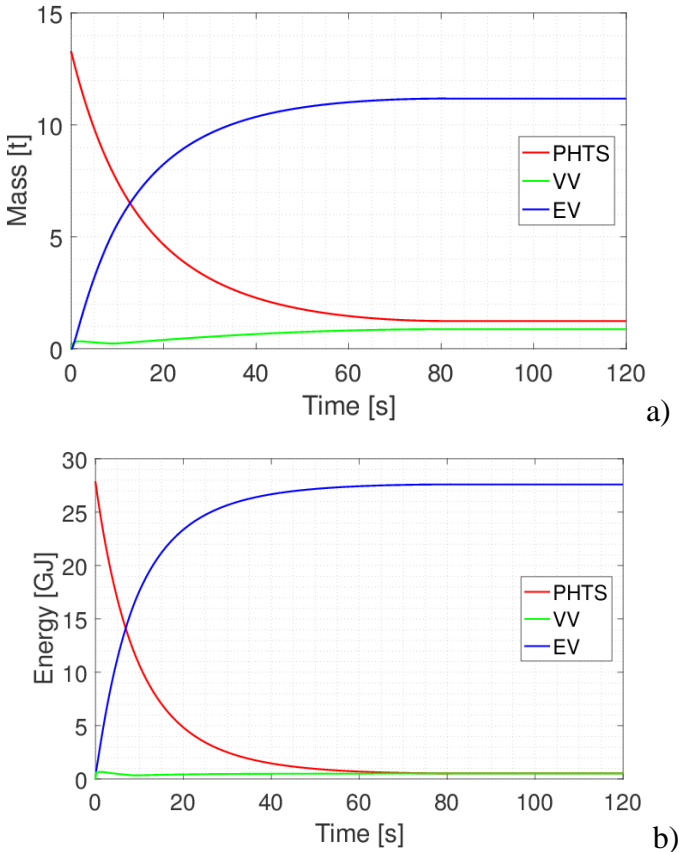

Figure 9: Evolution of the total mass (a) and energy (b) stored inside the three considered volumes for the benchmark scenario, as computed by GETTHEM. The mass inside the EV is plotted as increment with respect to the initial value.

4 CONCLUSIONS AND PERSPECTIVE

A simplified model of the EU DEMO VVPSS has been developed using the Modelica language within the system-level GETTHEM code. In this paper, the calibration and the benchmark of the model (for the case of helium-cooled BB) is performed against the already validated CONSEN model, giving successful results for temperature and pressure, which are the most relevant quantities for in-vessel LOCA safety system design and analysis which shall be performed during 2017.

In the benchmark scenario, the peak values of the helium pressure and temperature in the VV are accurately reproduced by the GETTHEM code, as well as the timing when these peaks are reached. A mod-

erate discrepancy is found in the estimation of the pressure reduction immediately after the peak value in the VV, while minor discrepancies are present in the evaluation of the total transient duration. The final value of pressure and temperature computed in each component are comparable for the two codes.

The high temperature value found at the end of the transient (higher than 700 K) in the EV suggests the application of an active cooling of the tank, even though, considering the timescales relevant in the heat exchange, this strategy would be effective only at the end of the transient.

Thanks to the positive results obtained in the benchmark exercise described in this paper, the GETTHEM model will be applied to parametric simulations on the EU DEMO VVPSS layout, in order to understand which parameters are to affect mostly the transient behaviour and to identify the most effective countermeasures that can be adopted in the VVPSS system design.

A further planned improvement of the GETTHEM model will be focused on the coupling of the VVPSS system with the more detailed 1D model of the PHTS system present in the GETTHEM library, in order to evaluate also the effect of this kind of scenario on the BB temperature and on the cooling circuit.

Finally, an analogous model for a water-cooled BB case is being built and validated, which will allow performing the same kind of analyses also for the water case and, eventually, a critical comparison of the helium and water solutions, in terms of *e.g.* sizing of the VVPSS.

ACKNOWLEDGEMENTS

This work has been carried out within the framework of the EUROfusion Consortium and has received funding from the Euratom research and training programme 2014-2018 under grant agreement No 633053. The views and opinions expressed herein do not necessarily reflect those of the European Commission.

REFERENCES

- ANSI/ISA 2007. Flow Equations for Sizing Control Valves. ANSI/ISA 75.01.01-2007 standard. [Online] Available: <https://www.isa.org/pdfs/microsites121/isa-750101-spbd/> (Accessed 08 January 2017).
- Bachmann, C. 2016. Personal communication.
- Caruso, G. 2007. CONSEN Users Guide. SRS-ENEA-FUS – Frascati (Italy).
- Caruso, G. 2016. Preliminary design of the expansion system for a DEMO reactor based on a helium-cooled blanket. DIAEE-NU(16)-0802 – Rome (Italy).
- Casella F. & Leva A. 2003. Modelica open library for power plant simulation: design and experimental validation.

- Proceedings of 3rd International Modelica Conference. - Linköping, Sweden, 3-4 November 2003, pp. 41-50.
- Casella F. & Leva A. 2006. Modelling of thermo-hydraulic power generation processes using Modelica. *Mathematical and Computer Modelling of Dynamical Systems*. 1(12): 19-33.
- Fritzson P. 2003. Principles of object-oriented modeling and simulation with Modelica 2.2, Wiley, 2003.
- Froio A. et al. 2016. Dynamic thermal-hydraulic modelling of the EU DEMO HCPB breeding blanket cooling loops. *Progress in Nuclear Energy* 93: 116-132.
- Froio A. et al. in press. Dynamic thermal-hydraulic modelling of the EU DEMO WCLL breeding blanket cooling loops. submitted to *Fusion Engineering and Design SOFT2016* special issue.
- Hurzlmeier H. & Meszaros B. 2015. EU DEMO1 2015 - DEMO_TOKAMAK_COMPLEX, EFDA_D_2M9AJJ.
- Mattsson S.E., Elmqvist H. & Otter M. 1998. Physical systems modeling with Modelica. *Control Engineering Practice*. 6: 501-510.
- Maviglia F. 2016. Thermo-hydraulic analysis with the RACLETTE code of the maximum first wall breaks size for an unmitigated DEMO disruption, v 0.1 (draft). Personal communication from F. Cismondi.
- Norajitra P. et al. 2015. DDD 2014 for HCPB, EFDA_D_2MCQCX v1.1.
- Romanelli F. et al. 2012. Fusion Electricity – A roadmap to the realisation of fusion energy. ISBN 978-3-00-040720-8T : European Fusion Development Agreement (EFDA).