



# EUROfusion

EUROFUSION WPMAG-CP(16) 15716

M. Lewandowska et al.

## **Experimental stand for thermal-hydraulic tests of forced flow conductors using water at room temperature**

Preprint of Paper to be submitted for publication in  
Proceedings of 29th Symposium on Fusion Technology (SOFT  
2016)



This work has been carried out within the framework of the EUROfusion Consortium and has received funding from the Euratom research and training programme 2014-2018 under grant agreement No 633053. The views and opinions expressed herein do not necessarily reflect those of the European Commission.

This document is intended for publication in the open literature. It is made available on the clear understanding that it may not be further circulated and extracts or references may not be published prior to publication of the original when applicable, or without the consent of the Publications Officer, EUROfusion Programme Management Unit, Culham Science Centre, Abingdon, Oxon, OX14 3DB, UK or e-mail [Publications.Officer@euro-fusion.org](mailto:Publications.Officer@euro-fusion.org)

Enquiries about Copyright and reproduction should be addressed to the Publications Officer, EUROfusion Programme Management Unit, Culham Science Centre, Abingdon, Oxon, OX14 3DB, UK or e-mail [Publications.Officer@euro-fusion.org](mailto:Publications.Officer@euro-fusion.org)

The contents of this preprint and all other EUROfusion Preprints, Reports and Conference Papers are available to view online free at <http://www.euro-fusionscipub.org>. This site has full search facilities and e-mail alert options. In the JET specific papers the diagrams contained within the PDFs on this site are hyperlinked

# Experimental stand for thermal-hydraulic tests of forced flow conductors using water at room temperature

Monika Lewandowska<sup>a</sup>, Wojciech Rachtan<sup>a</sup>, Aleksandra Dembkowska<sup>a</sup>, Leszek Malinowski<sup>a</sup>, Louis Zani<sup>b</sup>

<sup>a</sup>*West Pomeranian University of Technology, Szczecin, 70-310 Szczecin, Poland*

<sup>b</sup>*CEA, IRFM, F-13108 St-Paul-lez-Durance, France*

A new installation (THETIS) for thermal-hydraulic tests of forced-flow superconducting cables used in fusion technology, such as e.g. Cable-in-Conduit Conductors (CICCs), has been prepared at West Pomeranian University of Technology, Szczecin. The installation enables pressure drop measurements using water at room temperature in short samples of conductors in a wide range of Reynolds number. We present the new installation and demonstrate its capabilities by reporting the results of the first hydraulic test conducted on a reference sample (JT-60SA TF conductor). Further development of THETIS is foreseen to make possible measurements of heat transfer coefficients in superconducting cables.

Keywords: pressure drop, friction factor, superconducting cables

## 1. Introduction

Current models used for thermal–hydraulic analyses of forced-flow superconducting cables used in fusion technology are typically 1-D and they require reliable predictive correlations for the transverse mass-, momentum- and energy transport processes occurring between different cable components, in order to assess any fusion magnet design in both normal and off-normal operating conditions [1]. The void fraction of some Nb<sub>3</sub>Sn superconducting cables designed for the DEMO Toroidal Field coil is strongly reduced (down to about 20%) [2]. Conductors with such low void fractions have never been tested for pressure drop yet. Moreover, it was observed [2], that discrepancies between predictions of different bundle friction factor correlations available in literature [3-5] strongly increase with decreasing the void fraction. There is a need of experimental verification of the accuracy of the existing predictive friction factor correlations at very low void fractions. The situation with heat transfer phenomena in a CICC bundle is even less satisfactory. Only a few heat transfer correlations for flow in a CICC bundle have been proposed in literature [6-8], but none of them is widely accepted for predictive purposes. As a result, in thermal-hydraulic analyses of conductors designed for the DEMO coils [1,9-13] classical heat transfer correlations for flows in smooth tubes are used, which are definitely over-conservative in this case. Systematic measurements of heat transfer coefficients in a CICC bundle should be performed which could serve as a base for further attempts to develop a predictive correlation.

To reliably assess the predictive capability of an existing bundle friction factor correlation, or to develop a new one, it is beneficial to have experimental data measured in a possibly wide range of Reynolds number (Re). Friction factor data can be derived from pressure drop measurements using different fluids, e.g. water [14-18] or nitrogen [19,20] at room temperature (RT), or helium at room or cryogenic temperatures [5,17,18,

21-23]. The largest Re range can be reached when the same sample is tested with water and another, less viscous, fluid [17,18], however it would be desirable to have experimental data covering the whole considered Re range. Systematic experimental studies of pressure drop in CICC with different void fractions and cable layouts, using water at RT, were conducted in EPFL-CRPP [6-10], however in these experiments the maximum pressure at the sample inlet was 10 bar, which limited the maximum Re which could have been reached, particularly for conductors with low void fractions.

A new installation (THETIS) for thermal-hydraulic tests of forced-flow superconducting cables used in fusion technology, such as e.g. CICC, is being prepared at West Pomeranian University of Technology, Szczecin. The first stage of its construction has been completed. The aim of the paper is to present THETIS and demonstrate its capabilities by reporting the results of the first performed hydraulic test.

## 2. Experimental setup

### 2.1 THETIS installation

At the present stage the THETIS installation enables pressure drop tests of short conductor samples using distilled water at room temperature. The photo of the installation and its hydraulic scheme is presented in Figs. 1 and 2. The pressure head up to 25 bar in the installation is induced by a progressive cavity pump (BELLIN LZ 500L/KW) with variable speed operation. The mass flow rate in the circuit is adjusted by changing the rotational speed of the pump in the range 10 to 60 Hz. Two bypasses of the pump with different diameters enable precise adjustment of small mass flow rates by suitable opening of two throttle valves (VT-1 and VT-2 in Fig.2). The tolerable range of the water temperature in the pump is 10-50°C. A conductor sample is attached to the installation using flexible hoses with flange connections,

Table 1. Specification of the instrumentation used in THETIS

Measuring instrument	Type	Measured quantity	Measuring range	Basic measurement uncertainty
Flow meter	KROHNE OPTIMASS 1000	$\dot{m}$	20 - 3000 kg/h	$\pm 0.15\%$ of measured value
Temperature sensor 1 and 2	T-111-6-115-60-3-G1/2-NA-A-Pt 1000-400	$T_1, T_2$	-200 – 400 °C	$\pm 0.15\text{ °C} \pm 0.2\%$ of lmeasured value
Pressure sensor 1	Aplisens PR-28/0-25BAR/M20x1.5	$p_1$	0 – 2.5 MPa	$\pm 0.2\%$ of measuring range

Pressure sensor 2	Aplisens PR-28/0-10BAR/M20x1.5	$p_2$	0 -1 MPa	$\pm 0.2\%$ of measuring range
Differential pressure sensor 1	Aplisens APR-2000PD/0-250KPA/P/M20 x1.5	$\Delta p_1$	0 – 0.25 MPa	$\pm 0.1\%$ of measuring range
Differential pressure sensor 2	Aplisens APR-2000PD/0-16 BAR/P/M20x1.5	$\Delta p_2$	0 – 1.6 MPa	$\pm 0.1\%$ of measuring range
Data Acquisition System	APAR AR207	-	-	$\pm 0.1\%$ of measuring range

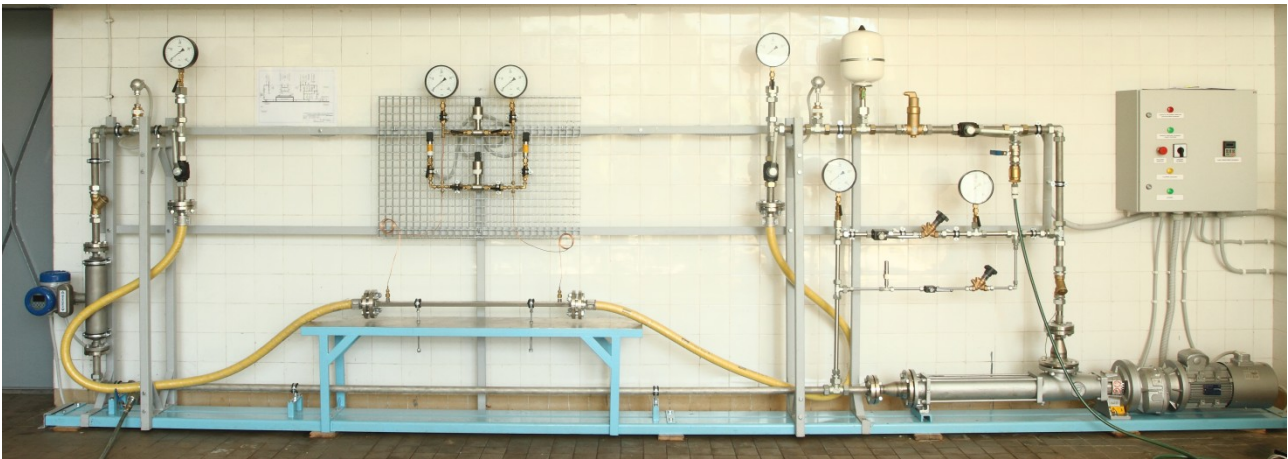

Fig. 1. Photo of the THETIS installation.

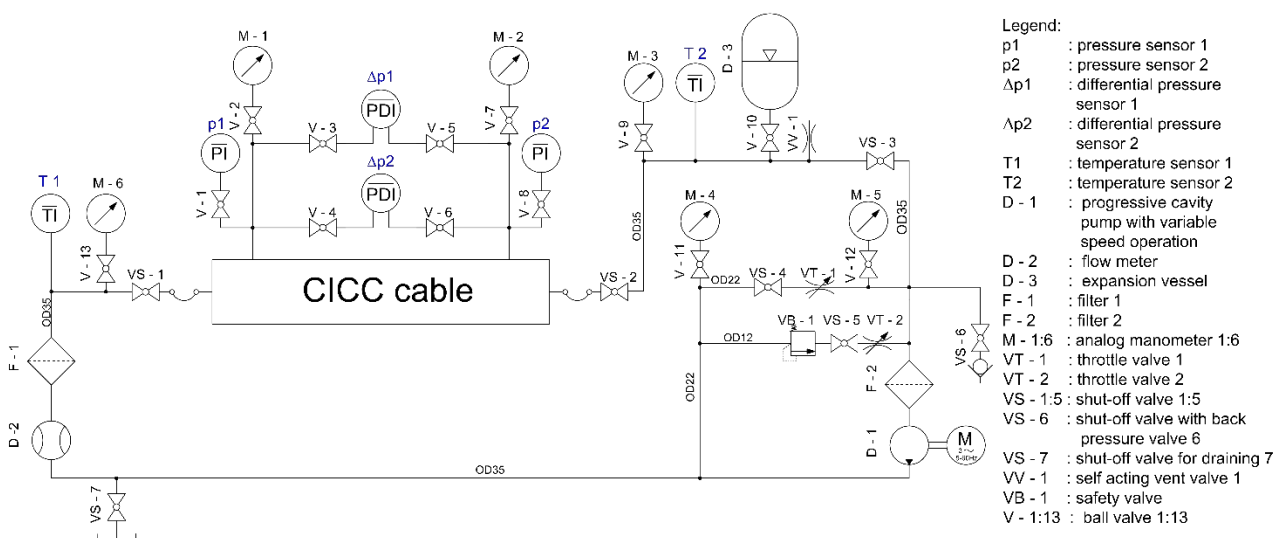

Fig. 2. Hydraulic scheme of the installation

is attached to the installation using flexible hoses with flange connections, which allows to vary the sample length in the range of about 0.5 to 2 m. The applied measuring instrumentation (see Table 1) and the automatic data acquisition system enable accurate and convenient measurements.

## 2.2 Reference sample

A reference sample used for the first pressure drop test performed with THETIS was the JT60-SA TF single channel CICC. Full characteristics of this conductor is given in [20, 24], whereas the conductor parameters relevant for the present study are recalled in Table 2. Fig. 3 shows the photo of the sample connected to THETIS.

Table 2. Characteristics of the JT-60SA TF sample [20]

Description	Symbol	Unit	Value
Void fraction	$\varphi$	%	32
Flow area	$A_f$	mm <sup>2</sup>	125.8
Hydraulic diameter	$D_h$	mm	0.454
Distance between pressure taps	$L$	m	0.865



Fig. 3. Photo of the JT-60SA TF sample.

## 3. Test results and discussion

The mass flow rate in the circuit was increased stepwise and readings of the sensors listed in Table 1 were registered every 1 s. The average values and their standard deviations were calculated for the data collected during steady states. To assess pressure drop in the sample, readings of the pressure sensors  $p_1$  and  $p_2$  were used in the range  $\Delta p > 1.6$  MPa, whereas the more accurate differential pressure sensors  $\Delta p_2$  and  $\Delta p_1$  were used in the range  $0.25 \text{ MPa} < \Delta p_2 < 1.6 \text{ MPa}$  and  $\Delta p_1 < 0.25 \text{ MPa}$ , respectively. The overlap between  $\Delta p$  values measured with different sensors was in good agreement within the range of uncertainties and confirmed the good accuracy of their calibration. The longitudinal Darcy friction factor ( $f$ ) and the Reynolds number were deduced from measurements of pressure drop and mass flow rate ( $\dot{m}$ ), according to the formulas:

$$f = (2D_h \rho A_f^2 \Delta p) / (\dot{m}^2 L), \quad (1)$$

$$\text{Re} = (\dot{m} D_h) / (\mu A_f), \quad (2)$$

where the water density ( $\rho$ ) and dynamic viscosity ( $\mu$ ) were calculated at the reference conditions:  $p_{ref} = (p_1 + p_2) / 2$  and  $T_{ref} = (T_1 + T_2) / 2$ . The combined uncertainties of the friction factor and Re were calculated as [25]:

$$u(f) = f \sqrt{\left[ \frac{u(\Delta p)}{\Delta p} \right]^2 + 2 \left[ \frac{u(\dot{m})}{\dot{m}} \right]^2 + \left[ \frac{u(L)}{L} \right]^2}, \quad (3)$$

$$u(\text{Re}) = (u(\dot{m}) D_h) / (\mu A_f). \quad (4)$$

The results of the performed test in the dimensionless form ( $f$  vs. Re) are presented in Fig. 4. Over seventy JT-60SA TF short samples, cut from different conductor unit lengths provided by manufactures, were tested for pressure drop in the OTHELLO test facility using nitrogen at RT [20]. Although the design of all these conductors was identical a noticeable scattering of the pressure drop test results was reported in [20]. The test results of two samples with the maximum and minimum friction factor, obtained in this experimental campaign have been added in Fig. 4. For the sake of comparison we have also included in Fig. 4 predictions of different friction factor correlations taken from literature [3-5].

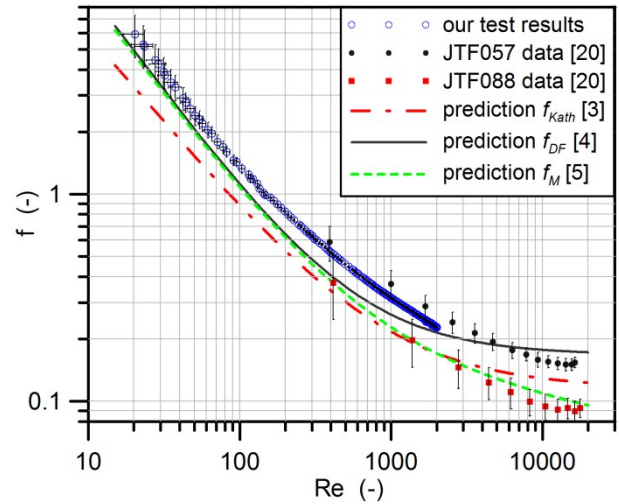

Fig. 4. Comparison of our test results with predictions of the friction factor correlations taken from literature [3-5] and with the extreme results of pressure drop test of similar samples performed at the OTHELLO test facility [20].

It is seen in Fig. 4 that our test results are consistent with the results of tests of similar samples performed at the OTHELLO test facility [20] and with predictions of friction factor correlations [3-5] used in thermal-hydraulic analyses of the DEMO TF coils [1,9-12]. The Re range achievable at THETIS and OTHELLO partially overlap. In the common Re range (400 - 2000) the accuracy of our measurements is better than that of OTHELLO. Both installations can be considered as complementary, and allow together to achieve a very wide Re range necessary for reliable

experimental verification of the existing friction factor correlations for conductors with very low void fraction.

#### 4. Summary, conclusions and perspectives

The new THETIS installation for thermal-hydraulic tests of forced flow cooled superconducting cables using water at RT is being prepared at the West Pomeranian University of Technology, Szczecin. At the present stage THETIS enables convenient and accurate pressure drop tests of short conductor samples. The performed pressure drop test of the reference sample (JT-60SA TF CICC) demonstrated that the Re range achievable in THETIS is complementary to that of the OTHELLO test facility. Further development of THETIS is foreseen, e.g. adding several temperature sensors as well as a heater at the sample inlet and a cooler at the pump inlet, to make possible measurements of heat transfer coefficients in superconducting cables. External teams are invited to send us conductor samples to be tested, on a collaborative basis.

#### Acknowledgments

This work has been carried out within the framework of the EUROfusion Consortium and has received funding from the Euratom research and training programme 2014-2018 under grant agreement No 633053. The views and opinions expressed herein do not necessarily reflect those of the European Commission. This scientific work was also partly supported by Polish Ministry of Science and Higher Education within the framework of the scientific financial resources in the year 2016 allocated for the realization of the international co-financed project.

We are indebted to B. Białecky for technical support.

#### References

- [1] R. Zanino, L. Savoldi Richard, A review of thermal-hydraulic issues in ITER cable-in-conduit conductors, *Cryogenics* 46 (2006) 541-545.
- [2] M. Lewandowska, K. Sedlak, L. Zani, Thermal-Hydraulic Analysis of the Low-Tc Superconductor (LTS) Winding Pack Design Concepts for the DEMO Toroidal Field (TF) Coil, *IEEE Trans. Appl. Supercond.* 26 (2016) 4205305.
- [3] H. Katheder, Optimum thermohydraulic operation regime for cable in conduit superconductors (CICS). *Cryogenics* 34 (1994) 595-598.
- [4] M. Bagnasco, L. Bottura, M. Lewandowska, Friction factor correlation for CICC's based on a porous media analogy, *Cryogenics* 50 (2010) 711-719.
- [5] M. Lewandowska, M. Bagnasco, Modified friction factor correlation for CICC's based on a porous media analogy, *Cryogenics* 51 (2011) 541-545.
- [6] S. Nicollet, D. Ciazynski, J.-L. Duchateau, B. Lacroix, B. Renard, Evaluation of the ITER cable-in-conduit-conductor heat transfer. *Proceedings of the 20<sup>th</sup> ICEC*, Beijing, China, Elsevier Ltd; 2005, 589-92.
- [7] L. Bottura, C. Marinucci, A porous medium analogy for the helium flow in CICC's, *Int. J. Heat Mass Transfer* 51 (2008), 2494-2505.
- [8] M. Lewandowska, L. Malinowski, Transverse heat transfer coefficient in the dual channel ITER TF CICC's. Part III: Direct method of assessment, *Cryogenics* 73 (2016) 91-100.
- [9] M. Lewandowska, K. Sedlak, Thermal-Hydraulic Analysis of LTS Cables for the DEMO TF Coil, *IEEE Trans. Appl. Supercond.*, 24 (2014) 4200305.
- [10] M. Lewandowska, K. Sedlak, Thermal-hydraulic analysis of the improved LTS conductor design concepts for the DEMO TF coil, *Prz. Elektrotech.* 92 (2016) 179-182.
- [11] R. Zanino *et al.*, Development of a Thermal-Hydraulic Model for the European DEMO TF Coil, *IEEE Trans. Appl. Supercond.* 26 (2016) 4201606.
- [12] R. Vallcorba *et al.*, Thermo-hydraulic analyses associated with a CEA design proposal for a DEMO TF conductor, *Cryogenics*, in print, 2016.
- [13] R. Zanino, L. Savoldi, Common approach for thermal-hydraulic calculations, memo for WPMAG-MCD-2.1, IDM Reference: EFDA\_D\_2LMECE.
- [14] P. Bruzzone, Pressure drop and helium inlet in the ITER CS1 conductor, *Fus. Eng. Des.* 58-59 (2001) 211-215.
- [15] C. Marinucci, P. Bruzzone, A. della Corte, L. Savoldi Richard., R. Zanino, Pressure drop of the ITER PFI cable-in-conduit conductor *IEEE Trans. Applied Supercon.* 15 (2005) 1383-1386.
- [16] M. Bagnasco, *et.al.*, Pressure drop of cable-in-conduit conductors with different void fraction, *Adv. Cryo. Eng.* 53 (2008) 1317-1324.
- [17] M. Bagnasco, M. Lewandowska, Pressure drop measurements in Cable-in-Conduit Conductors (CICC) with different layouts. *Proceedings of the 22<sup>nd</sup> ICEC-ICMC 2008*, Seoul, 865-870.
- [18] M. Lewandowska, M. Bagnasco, Pressure drop measurements in Cable-in-Conduit Conductors (CICC's) for an extended range of Reynolds number, *Przegl. Elektrotech.* 85 (2009) 155-157.
- [19] S. Nicollet, H. Cloez, J.L. Duchateau, J.P. Serries, Hydraulics of the ITER toroidal field coil cable-in-conduit conductors, *Proceedings of the 20<sup>th</sup> SOFT 1998*, 771-774.
- [20] P. Decool, *et.al.*, JT-60SA TF Coils: Experimental Check of Hydraulic Operating Conditions, *IEEE Trans. Appl. Supercond.* 26 (2016) 4201705.
- [21] J.W. Lue., J.R. Miller., J.C. Lottin, Pressure drop measurement on forced flow cable conductors, *IEEE Trans. Magn.* 15 (1979) 53-55.
- [22] M.A. Daugherty, Y. Huang, S.W. Van Sciver, Pressure drop measurements on supercritical helium cooled cable in conduit conductors, *IEEE Trans. Magn.* 25 (1989) 1512-15.
- [23] M.A. Daugherty, S.W. Van Sciver, Pressure drop measurements on cable-in-conduit conductors of various geometries, *IEEE Trans. Magn.* 27 (1991) 2108-2111.
- [24] L. Zani, P. Barabaschi, M. Peyrot, Starting EU Production of Strand and Conductor for JT-60SA Toroidal Field Coils, *IEEE Trans. Appl. Supercond.* 22 (2012) 4801804.
- [25] B.N. Taylor, C.E. Kuyatt., Guidelines for evaluating and expressing the uncertainty of NIST measurement results. *NIST Technical note 1297*, 1994.