



EUROfusion

EUROFUSION WPJET1-CP(16) 15348

M Lennholm et al.

Real time control developments at JET in preparation for deuterium-tritium operation

Preprint of Paper to be submitted for publication in
Proceedings of 29th Symposium on Fusion Technology (SOFT
2016)



This work has been carried out within the framework of the EUROfusion Consortium and has received funding from the Euratom research and training programme 2014-2018 under grant agreement No 633053. The views and opinions expressed herein do not necessarily reflect those of the European Commission.

This document is intended for publication in the open literature. It is made available on the clear understanding that it may not be further circulated and extracts or references may not be published prior to publication of the original when applicable, or without the consent of the Publications Officer, EUROfusion Programme Management Unit, Culham Science Centre, Abingdon, Oxon, OX14 3DB, UK or e-mail Publications.Officer@euro-fusion.org

Enquiries about Copyright and reproduction should be addressed to the Publications Officer, EUROfusion Programme Management Unit, Culham Science Centre, Abingdon, Oxon, OX14 3DB, UK or e-mail Publications.Officer@euro-fusion.org

The contents of this preprint and all other EUROfusion Preprints, Reports and Conference Papers are available to view online free at <http://www.euro-fusionscipub.org>. This site has full search facilities and e-mail alert options. In the JET specific papers the diagrams contained within the PDFs on this site are hyperlinked

Real Time Control Developments at JET in Preparation for Deuterium-Tritium Operation

M.Lennholm^{1,2}, I. S. Carvalho^{3,4}, K. Cave-Ayland⁴, A. Chagnard⁵, C. Challis⁴, R. Felton⁴, D. Frigione⁶, L. Garzotti⁴, A. Goodyear⁴, J.P.Graves⁷, C. Guillemaut^{3,4}, J. R. Harrison⁴, E.Lerche^{8,4}, P. J. Lomas⁴, R. Mooney⁴, F. Rimini⁴, A.C.C. Sips^{1,2}, C. Sozzi⁹, D. Valcarcel⁴, J. Vega¹⁰ and JET contributors*

EUROfusion Consortium, JET, Culham Science Centre, Abingdon, OX14 3DB, UK

¹*European Commission, B-1049 Brussels, Belgium*

²*JET Exploitation Unit, Culham Science Centre, Abingdon, OX14 3DB, UK*

³*Instituto de Plasmas e Fusão Nuclear, Instituto Superior Técnico, Universidade de Lisboa, P-1049-001 Lisboa, Portugal*

⁴*CCFE, Culham Science Centre, Abingdon, OX14 3DB, UK*

⁵*Ecole Centrale de Lille, 59651 Villeneuve d'Ascq, France ;*

⁶*ENEA, C.R. Frascati, Roma, Italy*

⁷*EPFL, CRPP, CH-1015 Lausanne, Switzerland*

⁸*Laboratory for Plasma Physics, Koninklijke Militaire School - Ecole Royale Militaire Renaissancelaan 30 Avenue de la Renaissance B-1000 Brussels, Belgium*

⁹*Istituto di Fisica del Plasma – CNR, Milano, Italy*

¹⁰*Laboratorio Nacional de Fusión. CIEMAT, Madrid, Spain*

** See the Appendix of F. Romanelli et al., Proceedings of the 25th IAEA Fusion Energy Conference 2014, Saint Petersburg, Russia*

Robust high performance plasma scenarios are being developed to exploit the unique capability of JET to operate with Tritium and Deuterium. In this context, real time control schemes are used to guide the plasma into the desired state and maintain it there. Other real time schemes detect undesirable behaviour and trigger appropriate actions to assure the best experimental results without unnecessary use of the limited neutron and Tritium budget. This paper discusses continuously active controllers and event/threshold detection algorithms triggering a variety of actions. Recent advances include: (i) Control of the degree of plasma detachment via impurity injection; (ii) ELM frequency control via gas/Pellet injection; (iii) Sawtooth pacing using ICRH modulation and (iv) the determination that a discharge is not evolving as desired, triggering a cascade of actions attempting to stop the plasma rapidly and safely, eventually triggering massive gas injection if a disruption is deemed unavoidable. For high power Deuterium-Tritium operation these control schemes need to be integrated into the plasma scenarios ensuring that they are mutually compatible.

Keywords: Real Time Control, Tritium Operation, Plasma Termination, ELMs, Sawteeth, Detachment, Isotope control.

1. Introduction

The JET tokamak is the only currently operating tokamak which can operate with the Deuterium-Tritium fuel mix required in a nuclear fusion reactor. The current JET plan envisages operation with pure Tritium (TT) plasma in 2018 followed by Deuterium-Tritium (DT) operation in 2019. Gaining further experience in operating a nuclear tokamak is considered essential for the success of ITER and the current and future JET programme is strongly focused on gathering the maximum information and experience from the upcoming TT and DT campaigns. The information sought encompasses the isotope scaling of H-mode threshold, confinement, ELM frequency etc. best gathered through TT experiments. The DT operation will provide valuable information on the physics of a plasma with significant alpha particle heating and neutron production. JET has undergone major changes since the

previous DT experiments in 1997 [1], the most important of which is the installation of the all metal ITER like wall in 2010-11, using Beryllium as first wall material in the main chamber and Tungsten in the Divertor, as foreseen for ITER [2-4]. Operation with DT fuel and with the ITER like wall poses a series of specific challenges as described in section 3. The current paper investigates the role that real time control can play in meeting these challenges.

2. JET real time control architecture

Two core control systems are required for the routine operation of the JET machine: The Plasma Position and Current Control system (PPCC) uses the poloidal coils as actuators while the density control system (PDF) uses gas injection as its actuator. Though these systems are not discussed further, it is understood that they are active together with all the controllers discussed. The

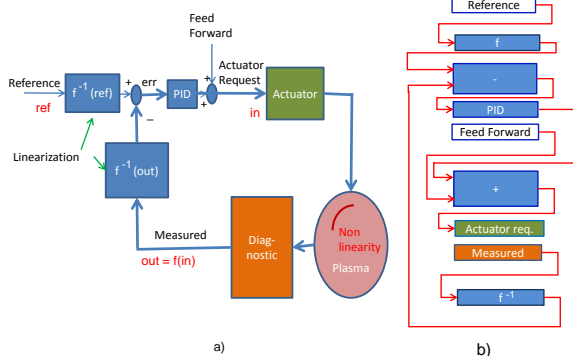

Fig.1 a) A simple closed loop algorithm with compensation for static nonlinearity. b) Schematic illustration of the implementation of this controller in the RTCC language.

controllers described in the following are running in a central controller (RTCC) which receives data, in real time, from a large number of JET measurement systems and real time processors [5]. RTCC can output request signals to various actuators, notably heating and gas introduction systems but also to PPCC and PDF. The programming of controllers in RTCC is done in a high level, block diagram language where each block in a standard block diagram is translated into a line in the programme. The user can program a control algorithm without having to worry about interface issues and as a consequence simple control algorithms can be implemented rapidly – even ‘on the fly’ during sessions.

Figure 1a shows a simple single input single output (SISO) control scheme which is representative of a number of the controllers used at present at JET. The controller includes a nonlinear function which corrects for a known static nonlinearity in the input output map. The simple implementation in the RTCC high level language is shown schematically in figure 1b. For a robust implementation a few bells and whistles have to be added including things like limits and anti-windup.

Four separate control algorithms can run simultaneously within RTCC. Multi input multi output (MIMO) controllers with up to 3 inputs and 3 outputs have been implemented in a single algorithm and this is close to the current limit of the system capabilities. The possibility of upgrading the system to allow more complicated algorithms, while simplifying the interface for the operators, is under investigation.

3. Operational challenges and the role of real time control in meeting them.

Tungsten influx: The dominant change associated with the installation of the ITER like wall on JET, already well documented on ASDEX-Upgrade [6], is the tendency of tungsten to accumulate near the plasma centre [7-8]. Such accumulation can lead to a radiation collapse invariably causing a disruption. Several techniques have been developed to avoid or counter this accumulation. It turns out that ELMs, while sputtering tungsten from the divertor, also help to expel tungsten from the plasma edge. As a consequence a high ELM frequency can help limit impurity influx [9]. Once the tungsten has moved beyond the reach of the ELMs it

moves towards the centre of the plasma. Here sawteeth are seen to expel tungsten effectively towards the outer part of the plasma. [10-11]. A final tool, effective in preventing excessive tungsten accumulation, is central electron heating [12]. On JET such heating can be provided by ICRH, whereas ECRH has been shown to be effective on ASDEX-Upgrade. Effective avoidance of tungsten accumulation using these tools is readily achievable on JET, but a heavy price can be paid in terms of confinement if ELM and sawtooth frequencies are increased excessively. Real time control of ELM and sawtooth frequencies can play an important role in achieving the optimal compromise, avoiding tungsten accumulation while maintaining good confinement.

Divertor Energy Handling: A second, though linked, challenge posed by the metal wall is its limited power and energy handling. Maintaining a sufficiently high ELM frequency is again desirable, though other techniques also need to be employed. These techniques include sweeping the divertor strike-point location and the introduction of light impurities into the divertor region to radiate energy locally, creating a partially or fully detached plasma. Finally a reduction in the input power may prove necessary. Real time control can play a crucial roll in controlling radiation, detachment and divertor heat load allowing the best possible plasma performance while staying within the limits imposed by the divertor power and energy handling capability.

Disruptions: A less obvious complication in the operation with the metal wall is the fact that disruption forces have increased significantly in comparison with carbon wall operation. This is exacerbated by the fact that the new walls, especially the beryllium in the main chamber, are prone to flash melting during disruptions. Prevention, prediction and mitigation of disruptions have therefore become even more important. Avoiding tungsten accumulation is probably the most important prevention action, though preventing the triggering of NTMs through sawtooth shortening and limitation of beta are also important. Early prediction that the plasma is heading towards a disruption may allow the disruption to be prevented by initiating a predetermined termination scenario [13-14]. A range of termination scenarios have been developed, each optimised for the specific conditions triggering the initiation of the termination. Once it is clear that a disruption is imminent the main mitigating action employed at JET is the firing of the disruption mitigation valve injecting a large amount of gas terminating the discharge rapidly while radiating

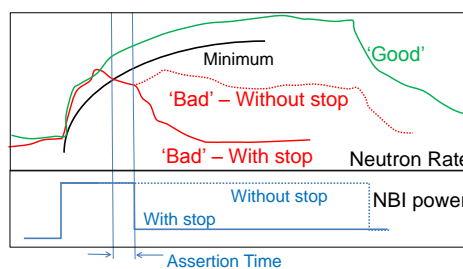

Fig.2 ‘Dud’ detection. When the neutron production is deemed unsatisfactory, the pulse is terminated.

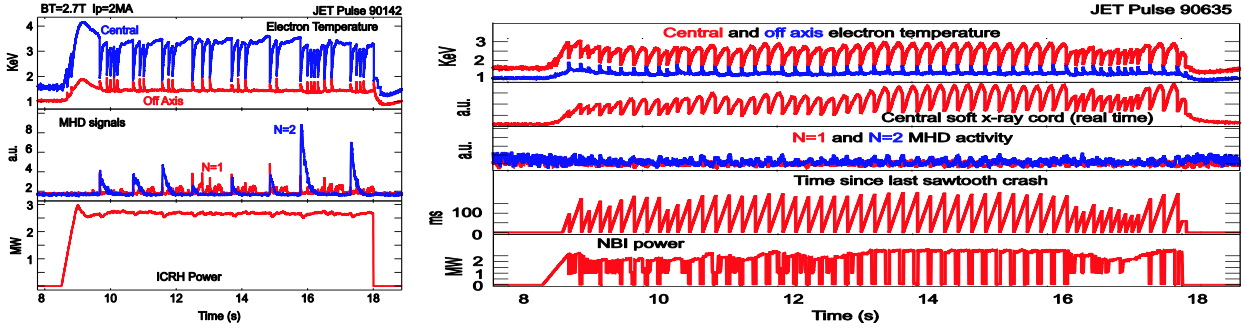

Fig.3 Sawtooth and N=2 activity for two discharges: 'a) Constant ICRH power. Long sawteeth trigger N=2 NTMs. (90142); b) Effective sawtooth pacing leading to the avoidance of NTMs.

most of the plasma energy.

Dud detection: The main concern when operating with tritium, especially in active operation with deuterium-tritium plasmas, is to make optimal use of the limited amount of tritium available and to consume the severely restricted neutron budget wisely. Determining, in real time, when a discharge is unlikely to be of scientific value and, if so, terminating it safely can result in significant reduction in neutron production and Tritium consumption. In DT discharges the simplest way to do this, already exploited during the JET DTE 1 experiments in 1997, is to monitor whether the neutron rate remains above a predetermined curve. Figure 2 illustrates the idea behind such a scheme. Other signals, such as impurity content and heating power can also be used to determine whether a discharge should be terminated early.

Isotope control: A second issue, which will be more important during DT operation, is the control of the isotope ratio as required to achieve maximum fusion power. Controllers developed for this purpose are closely related to existing minority concentration controllers used in ICRH heated discharges.

4. Real Time Controllers in use at JET

A number of real time controllers have been developed at JET, each contributing to meeting one or more of the challenges outlined above. In the following, experimental evidence of the effectiveness of each of these controllers is discussed.

ELM frequency control: An ELM frequency controller is routinely used at JET. This controller exploits the fact that, under most conditions, the ELM frequency increases with gas injection rate. This controller, which is effective in its own right, is also regularly used as a 'safety net'. In this case it only acts when the ELM frequency drops below a threshold. When this happens the controller becomes active and injects gas to maintain the frequency at the required minimum. When triggering ELMs through pellet injection, this is particularly useful due to the variability in the pellet ELM triggering efficiency [15-17].

Sawtooth Pacing. Controlling the sawtooth period with a view to preventing large sawtooth crashes from triggering of Neoclassical Tearing Modes (NTMs) has been investigated on JET over the last decade [18-20]. All the techniques developed in this research rely on

locating the ICRH deposition near the $q=1$ surface to destabilise the $m,n=1,1$ mode, inducing more frequent sawteeth. Similar techniques using ECRH have been explored on other Tokamaks [21-24]. TCV has also demonstrated the pacing of sawteeth using modulation of centrally deposited ECRH [25-26]. Given the strong stabilising effect of central ICRH, pacing sawteeth using modulated centrally deposited ICRH should be very effective [27]. This has indeed been proven by recent experiments on JET [28]. In these experiments the ICRH modulation was controlled in real time, switching the ICRH power off when the time since the previous sawtooth crash exceeded a threshold and then switching it back on as soon as a new sawtooth crash is detected. Figure 3 shows two pulses, a) without sawtooth pacing and b) with sawtooth pacing. In a) long sawteeth lead to the triggering of N=2 NTMs while sawteeth are effectively paced in b) leading to the complete absence of long sawteeth and NTMs. In b) the threshold for switching off the ICRH is set to 0.15s. The time between the request to switch off ICRH and the triggering of a sawtooth is ~ 50 ms in this pulse, leading to a sawtooth period < 0.2 s throughout the pulse. Note that the real time control means that the ICRH is not switched off when the natural sawtooth period is sufficiently short. The real time control therefore maximises the ICRH duty cycle allowing the optimal use of ICRH for central heating and effective tungsten screening, while assuring NTM avoidance and tungsten flushing by keeping the sawtooth period low.

Detachment Control: A feedback controller, controlling the divertor detachment fraction has recently been developed at JET [29]. The controller uses the ion saturation current (I_{sat}) measurements from an array of Langmuir probes, situated in the divertor, to determine the degree of detachment in real time. The detachment is controlled, in feedback, by injecting nitrogen into the divertor. Figure 4 shows a sketch of the steady state map relating input gas to ion saturation current for the

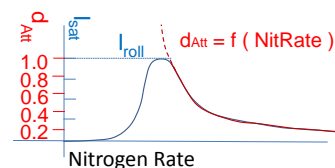

Fig.4 Sketch showing attachment fraction $d_{Ait} = I_{sat}/I_{roll}$ as a function of input gas flow rate (blue) and an exponential curve matching this for nitrogen rates beyond the rollover (red).

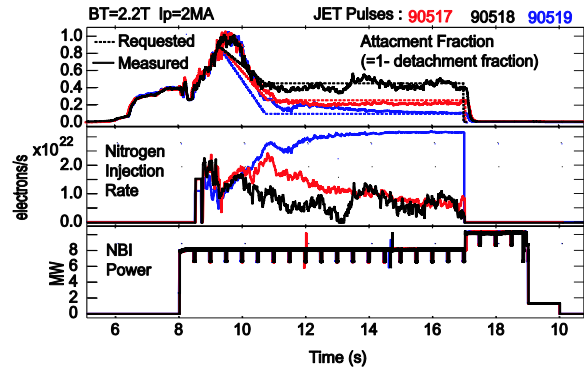
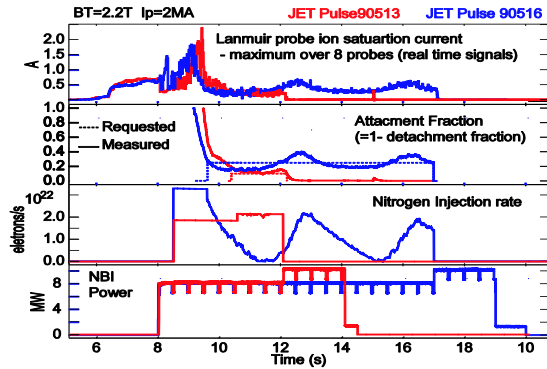

Fig.5 Closed loop detachment control without a) and with b) compensation for the non-linearity seen in figure 4.

Langmuir probe situated closest to the divertor strike point. This curve exhibits a maximum and the value at this point is termed the ‘roll over’ saturation current I_{roll} . The degree of detachment d_{Det} at this point is zero by definition. At higher impurity injection rates the degree of detachment is defined as $d_{Det} = (I_{roll} - I_{sat})/I_{roll}$, which reaches one when the ion saturation current drop to zero. For simplicity the controlled value is the ‘attachment fraction’ $d_{Att} = 1 - d_{Det} = I_{sat}/I_{roll}$. With this definition figure 4 directly translates into showing attachment fraction as a function of gas injection rate. As the input output map is non monotonic the controller sign must change when moving from left to right of the roll over point. This is handled by starting with a constant, large, gas flow, continuously detecting the maximum I_{sat} which has been reached since the start of the discharge. Once I_{sat} drops clearly below this maximum the controller assumes that the right hand side of the input output map, where d_{Att} decreases with increased gas injection, has been reached and closed loop control is started.

Figure 5a shows the result of two similar discharges, one shortened for operational reasons, using this controller with different requested attachment fractions. The fact that low attachment fraction leads to stable controller behaviour while a higher attachment fraction results in controller oscillations is caused by the static non-linearity in the input output map. The non-linearity can be eliminated from the closed loop by introducing a non-linear compensating block in the control diagram as suggested in figure 1 resulting in stable operation over a range of attachment fractions as illustrated by figure 5b. The exponential curve used to produce this linearization, valid for nitrogen injection larger than the rollover value, is shown schematically by full and dashed red lines in

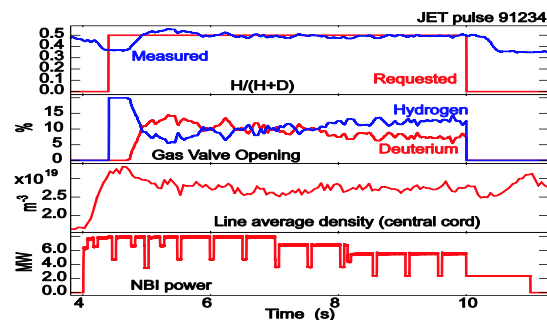

Fig.6 Hydrogen-Deuterium mixture control. (#91234). The controller compensates for the disturbance introduced by variations in the deuterium neutral beam power.

figure 4.

Plasma Composition Control: As mentioned in section 2 it is desirable to control the isotope ratio, especially during DT operation. Figure 6 shows an example where the isotope mix is maintained efficiently at 50% Hydrogen, 50% Deuterium by such a controller. Two gas injection modules, one injecting deuterium and one injecting hydrogen, are used simultaneously varying the ratio of the two gas injection rates, while keeping the total injection rate constant. The isotope ratio is determined in real time using spectroscopic signals [30]. Similar control schemes are also used for controlling the H and He₃ minority fraction for optimisation of ICRH absorption.

5. Multi Input Multi Output Control

The previous section described a number of individual single input single output controllers. When moving on to Deuterium Tritium operation it is important that these controllers can operate together. Experience with the simultaneous operation of the controllers required for high power ILW operation remains very limited. Figure 7a shows the JET ELM frequency and He₃ controllers operating together. It should be noted that the ELM frequency controller rapidly reaches saturation level and it is not clear whether the two controllers, which are likely to exhibit a not insignificant coupling, would have operated satisfactorily if neither of them had been running against their limits. Figure 7b shows the operation of the JETs standard beta controller using NBI power as actuator combined with a bang/bang controller which steps up the gas injection strongly when the plasma radiation peaking, defines as the ratio between a central and an off axis bolometer channel, is seen to exceed a certain threshold and reduces the gas injection again when the peaking returns below another, lower, threshold. In the discharge shown the gas helps to keep the plasma alive for a while but, eventually, strong MHD activity triggers a plasma termination.

The combination of controllers in figure 7 only scratches the surface of the likely future requirement for combining controllers. A study investigating the simultaneous use of deuterium injection, nitrogen injection and NBI power to control ELM frequency, radiated fraction and normalised beta, has been undertaken and a decoupled MIMO controller has been developed. The principle used in developing this controller is based on the observation that the main time

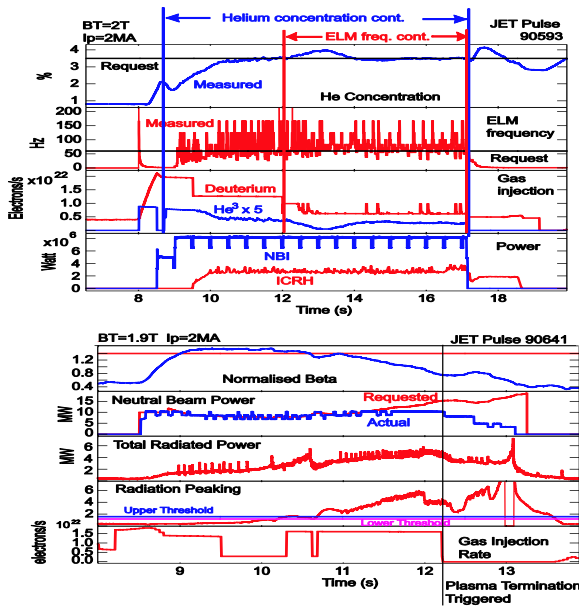

Fig.7 a) simultaneous control of the ELM frequency and He₃ concentration by injection of Deuterium and He₃ gas. b) simultaneous operation of a normalised beta controller by NBI and a bang/bang control scheme aimed at reacting to radiation peaking. At 12.2 seconds a discharge termination is triggered due to the detection of MHD activity.

constants in this system can be associated with the individual actuators. Around a certain operating point this allows us to describe the plasma as a 3x3 matrix. By inserting the inverse of this plasma matrix into the controller, as illustrated in figure 8a, we can eliminate the cross coupling terms. Figure 8b shows a simulation of the behaviour of such a controller. Though the matrix used for determining the decoupling matrix is based on a specific operating point, the model used for the simulation does take into account, albeit crudely, the nonlinear plasma response.

6. Conclusions

Operation of JET with the all metal ITER like wall together with the planned operation with Deuterium Tritium plasma poses a variety of challenges. A number of real time controllers have been developed to help meeting these challenges, including ELM and sawtooth frequency controllers, detachment controllers and mixture controllers.. Assuring that these controllers can be combined effectively remains the main real time control task to be completed in preparation for the upcoming Deuterium Tritium experimental campaigns.

Acknowledgments

This work has been carried out within the framework of the EUROfusion Consortium and has received funding from the Euratom research and training programme 2014-2018 under grant agreement No 633053. The views and opinions expressed herein do not necessarily reflect those of the European Commission. The work of A. Chagnard received the support of the French Embassy in London.

References

[1] M. Keilhacker et al., Nucl. Fusion **39**, 209 (1999).

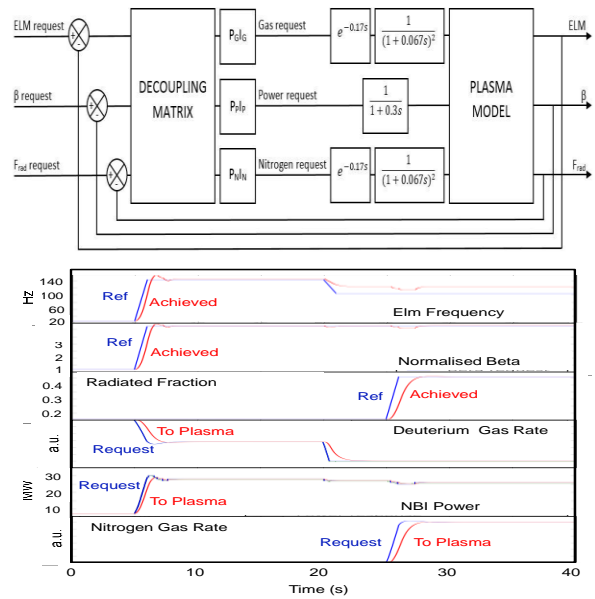

Fig. 8 MIMO controller: a) 3x3 control block diagram the decoupling matrix is the inverse of the steady state plasma matrix in the linearization point. b) Simulation of 3x3 control

- [2] F. Romanelli et al., Nucl. Fusion, **53**, 104002, (2013)
- [3] G.F. Matthews et al., Physica Scripta, 014001. (2011)
- [4] R. Neu et al., Phys. of Plasmas, **20**. 056111, (2013).
- [5] Q. King and H. Brelen, JET preprints JET-P(98), (1998).
- [6] R. Neu et al., Plas.Phys.Cnt.Fus. **49** 12B (2007) B59-B70
- [7] E. Joffrin et al., Nucl. Fusion, **54**, 013011, (2014)
- [8] M.Beurskens et al. Plas.Phys.Cnt.Fus. **55**, 124043 (2013)
- [9] T. Pütterich et al., Plas.Phys.Cnt.Fus., **55**, 124036, (2013)
- [10] Graves J. et al. Plas.Phys.Cnt.Fus **57** 014033 (2015)
- [11] I. Chapman et al, Nucl. Fusion, **50**, 102001, (2010)
- [12] E. Lerche et al., Nucl. Fusion **56** 036022 (2016)
- [13] J. Vega et al., Fusion Eng. Des., **88**, 6–8, 1228 (2014)
- [14] R. Moreno, J. Vega, et al. Fus.Sci.Tech. **69** · 485 (2016)
- [15] M. Lennholm et al. Nucl. Fusion **55** 063004 (2015)
- [16] M. Lennholm et al. Nucl. Fusion **56** 016008 (2016)
- [17] L.-G. Eriksson et al. Phys. Rev. Lett., **92**, 235004, (2004).
- [18] J. P. Graves et al. Nature Comms., **3**, 626, (2012).
- [19] J. P. Graves et al. Phys. Rev. Lett, **102**, 065005, (2009).
- [20] M. Lennholm et al., Nucl. Fusion, **51**, 073032 (2011).
- [21] C. Angioni, et al. Nucl. Fusion, **43**, 455 (2003).
- [22] A. Mück et al, Plas.Phys.Cnt.Fus., **43** 1633, (2005).
- [23] J. I. Paley et al., Plas.Phys.Cnt.Fus. **51**, 055010, (2009).
- [24] M. Lennholm et al., Phys.Rev. Lett. **102**, 115004, (2009).
- [25] T.P.Goodman, et al. Phys. Rev. Lett., **106**, 245002, (2011)
- [26] M. Lauret, et al. Nucl.Fusion, **52**, 062002, (2012)
- [27] M. Lauret et al. Accepted (Plas.Phys.Cnt.Fus)
- [28] E. Lerche et al. Submitted NF
- [29] C. Guillemaut et al. Submitted PPCF
- [30] D. Valcarcel et al. In preparation