



EUROfusion

EUROFUSION WPHCD-PR(15) 14904

A Garcia Perez et al.

Effect on the Tritium Breeding Ratio for a distributed ICRF antenna in a DEMO reactor

Preprint of Paper to be submitted for publication in
Fusion Engineering and Design



This work has been carried out within the framework of the EUROfusion Consortium and has received funding from the Euratom research and training programme 2014-2018 under grant agreement No 633053. The views and opinions expressed herein do not necessarily reflect those of the European Commission.

This document is intended for publication in the open literature. It is made available on the clear understanding that it may not be further circulated and extracts or references may not be published prior to publication of the original when applicable, or without the consent of the Publications Officer, EUROfusion Programme Management Unit, Culham Science Centre, Abingdon, Oxon, OX14 3DB, UK or e-mail Publications.Officer@euro-fusion.org

Enquiries about Copyright and reproduction should be addressed to the Publications Officer, EUROfusion Programme Management Unit, Culham Science Centre, Abingdon, Oxon, OX14 3DB, UK or e-mail Publications.Officer@euro-fusion.org

The contents of this preprint and all other EUROfusion Preprints, Reports and Conference Papers are available to view online free at <http://www.euro-fusionscipub.org>. This site has full search facilities and e-mail alert options. In the JET specific papers the diagrams contained within the PDFs on this site are hyperlinked

Effect on the Tritium Breeding Ratio for a distributed ICRF antenna in a DEMO reactor

A. Garcia^{1, 2, 3, 4 a)} J-M Noterdaeme^{1, 4} U. Fischer² J. Dies³

¹Max-Planck-Institut für Plasmaphysik (IPP), Garching, Germany

²Karlsruhe Institute of Technology (KIT), Karlsruhe, Germany

³Polytechnic University of Catalonia (UPC), Barcelona, Spain

⁴Department of Applied Physics, Ghent University, Ghent, Belgium

^{a)}albert.garcia.hp@gmail.com

Abstract. This thesis reports results of MCNP-5 calculations, with the nuclear data library FENDL-2.1, to assess the effect on the Tritium Breeding Ratio (TBR) for a distributed Ion Cyclotron Range of Frequencies (ICRF) antenna integrated in the blanket of a DEMO fusion power reactor. A representative configuration of both the antenna and the DEMO reactor was used together with a parametric analysis for the parameters that most strongly affect the TBR. These are the type of breeding blanket (Helium Cooled Pebble Bed, Helium Cooled Lithium Lead and Water Cooled Lithium Lead), the covering ratio of the straps of the antenna (the ratio between the surface of all the straps and the projected surface of the antenna slot: 0.49, 0.72 and 0.94), the depth of the antenna (20 cm and 40 cm), the thickness of the straps (2 cm, 4 cm and a double layer of 0.2 cm plus 2.5 cm with the composition of the First Wall), and finally the poloidal position of the antenna (0°, which is the equatorial port, 40° and 90°, which is the upper port). For an antenna with a full toroidal circumference of 360°, located poloidally at 40° with a poloidal extension of 1 m and a total First Wall surface of 67 m², the reduction of the TBR is -0.35% for a HCPB blanket concept, -0.53% for a HCLL blanket concept and -0.51% for a WCLL blanket concept. In all cases, covered by the parametric analysis, the loss of TBR remains above than -0.61%. Such a distributed ICRF antenna has thus only a marginal effect on the TBR for a DEMO reactor.

1. INTRODUCTION

A DEMO fusion power reactor [1] must be self-sufficient in tritium. Hence, a net Tritium Breeding Ratio (TBR – the ratio of T produced in the blanket to the T consumed in the core reactions) greater than one is essential. Some margin is required to account for tritium losses and uncertainties. The typical design targets the global TBR required in the range of 1.05 to 1.15 [2]. The integration of diagnostics, plasma heating components, etc. deteriorates the TBR due to the required replacement of breeder blanket parts by non-breeding materials or volumes. Recently, a new concept for the Ion Cyclotron Range of Frequencies (ICRF) antenna integrated within the blanket has been proposed [3] (see Figure 1). From the ICRF point of view, the antenna presents large advantages (low power density, no use of equatorial ports, better definition of the k-spectrum), but the impact on the TBR is less evident. The antenna uses a large surface but, in contrast to a port opening, it does not require a large volume at expense of the blanket breeder. The effect on the TBR is due to the combination of three effects:

1. Parasitic absorption of neutrons in the antenna
2. Moderation of neutrons affecting the neutron spectrum
3. A reduction of the total breeding blanket volume

The objective of this paper is to quantify this loss of TBR and thus to check if such an antenna is compatible with the TBR requirements of DEMO. The assessment has been performed for the European DEMO power reactor and three types of breeder blanket concepts, the Helium Cooled Pebble Bed (HCPB), the Helium Cooled Lithium Lead (HCLL) [4] and the Water Cooled Lithium Lead (WCLL) [5]. The calculations were done at KIT (Karlsruhe Institute of Technology) using the Monte Carlo N-Particle code MCNP, version 5 [6], and nuclear cross-section data from the Fusion Evaluated Nuclear Data Library (FENDL-2.1) [7].

Some variations in the design were considered to study their effect on the calculated TBR: in addition to the breeding blanket concepts which strongly affect the TBR, the covering ratio of the straps of the antenna, the depth of the antenna, the thickness of the straps and the poloidal position of the antenna have been varied to estimate the loss of TBR.

2. BLANKET

The European fusion technology programme considers two blanket development lines which will be tested in ITER [8], the HCPB blanket with Lithium ceramics pebbles as breeder material and beryllium pebbles as neutron multiplier [4], and the HCLL blanket with the Pb-Li eutectic alloy acting both as breeder and neutron multiplier [9]. Both, as well as the WCLL [5] blanket, another EU design which will not be tested in ITER, are considered in this paper.

The DEMO-tokamak is divided into 22.5° symmetric sectors (16 in total¹). For the in-vessel components (First Wall, Blanket and Manifold) each sector is composed by 2 inboard and 3 outboard segments [3]. The outboard segments consist of a Central Outboard Blanket Segment (COBS) between the toroidal field coils, a Right and a Left Outboard Blanket Segments (ROBS and LOBS respectively) each partly under a toroidal field coil. Both outboard and inboard segments contain 6 modules. Figure 1 shows the corresponding CAD model into which the ICRF antenna has been integrated. Because of symmetries, only 11.25° needs to be considered.

The model includes the in-vessel components (breeding blanket modules with manifolds and shields, the vacuum vessel, the divertor and the ports). The contribution of the toroidal and poloidal coils are neglectable when calculating the TBR. The First Wall of the blanket modules consist of 2 mm tungsten on top of 25 mm cooled Eurofer. The breeding material consist of a homogeneous composition of 57% Beryllium (neutron multiplier) + 19% Li_4SiO_4 (ceramic breeder with ^6Li enriched up to at. 60%) + 15% EUROFER (cooling plates and stiffening grid) + 9% He (coolant). Behind the breeding zone a cooled Eurofer mixture is used for both the backplates of the blanket and the manifold. The model has been developed at KIT in the frame of the Power Plant Physics and Technology Programme (PPPT) under EFDA [10] but takes into account a recent update conducted in 2014 with the EUROfusion PPPT programme.

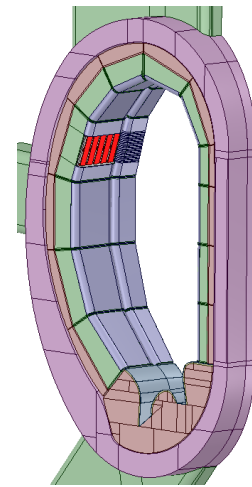

FIGURE 1. DEMO torus sector model with blanket modules and distributed antenna integrated (Faraday screen partially removed)

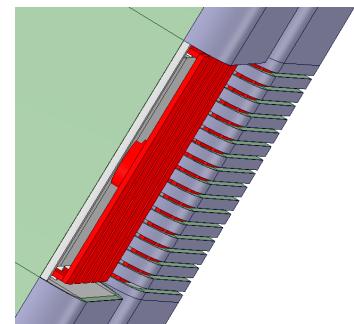

FIGURE 2. Antenna (Faraday Screen partially removed)

¹ This was the design for which the calculation was made. The present design considers 18 coils but this will not affect the fundamental result.

3. DISTRIBUTED ANTENNA

To be acceptable the antenna must comply with the following conditions:

- The antenna must not impair any blanket function: it has to keep ensuring the tritium self-sufficiency and the capability to extract the energy from the fusion reaction.
- The antenna must match the blanket modularity and not require extra openings in the vessel: each blanket module is independent from the others, so the antenna can't require an internal connection between modules and it must use one of the already existing ports for the feeding lines.
- The antenna must share the same coolant of the blanket: He or water, the cooling system must be integrated with the one of the blanket.
- The antenna must not increase the complexity of the Remote Handling: the remote handling of the blanket is a complex system through the upper port where the pipes and tubes are welded and rewelded outside the VV [11]. Hence, the remote handling for the antenna must work in the same way.

The detailed configuration of the antenna is still being defined, and in particular the feeding of the antenna. The calculations therefore limit itself to the antenna only and the following assumptions were made.

The reference antenna is a toroidal 360° ring array of straps embedded in a poloidal module of the blanket and its Faraday screen is flush with the First Wall (FW). The straps are placed inside a slot in the module as can be seen in Figure 1 – 4. The slot measures 100 cm poloidally and is 20 cm deep. Within the slot, the straps of the ring array have each a width of 20 cm-width straps (toroidal direction) with a separation by 6 cm between straps, and the thickness of the straps is 2 cm [12]. As can be seen in Figure 2 and Figure 3 the antenna is not filling all the space in the slot.

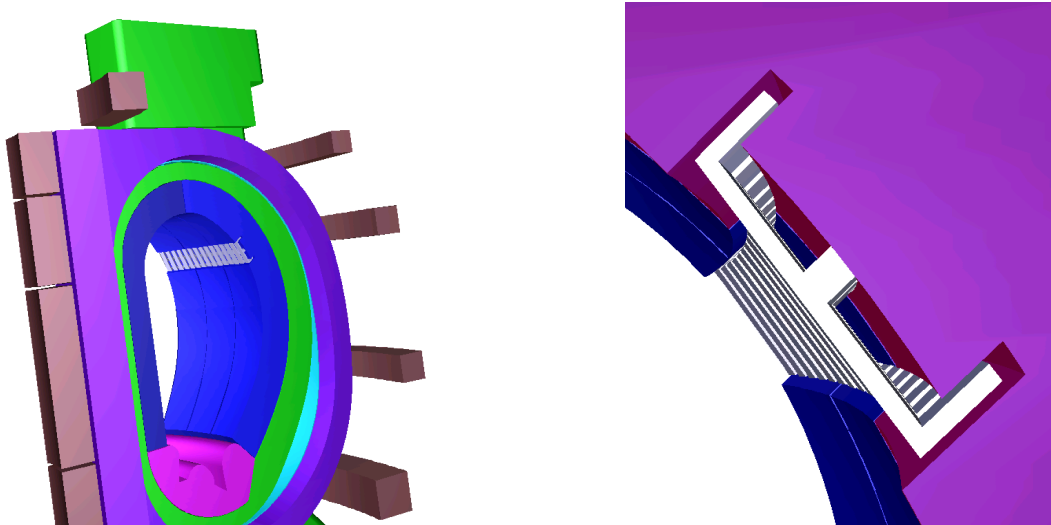

Figure 3. Draft of the reference ICRF antenna integrated in a DEMO reactor

For the material of the antenna, the same material is used as for stiffening the blanket (Eurofer). Alternatively, due to its position near the plasma, tungsten may be required, although the presence of a Faraday screen may alleviate this. For the time being the feeding lines through the blanket have been neglected. For the Faraday screen the same material as the FW has been used (2 mm of tungsten and 25 mm of He-cooled Eurofer). The tentative poloidal dimensions of the Faraday screen were chosen to be 4.2 cm of FW alternating with 1.5 cm of open space. In Fig. 1 the antenna integrated in the blanket can be seen, with the Left Outboard Blanket Segment (LOBS) and half of the Central Outboard Blanket Segment (COBS) shown. In the COBS, the Faraday screen has been removed for a more illustrative picture.

4. CALCULATIONS

As noted above, the DEMO model developed at KIT for the HCPB blanket was used as the reference model. The CAD model of the ICRF antenna was integrated into this model using the SpaceClaim software [13]. The resulting CAD geometry model was then converted into MCNP geometry using KIT's McCad interface [14]. The calculations were carried out using the MCNP-5 code and the FENDL-2.1 nuclear data library on 11.25° torus sector while taking symmetries into account. The track length estimator [15] was used to calculate the TBR. Typically 100 million neutron source histories were tracked in a MCNP run to get sufficient statistics. The results for the reference configuration defined previously are shown first and a parametric analysis on different parameters is done later.

4.1 Reference configuration

Table 1 shows the neutron balance and the effect on the TBR of the considered cases. When two numbers appear in the table, the left one refers to the mean and the right one to the error in percentage from the mean. Although the antenna takes up 360° around the torus, the breeding volume removed is small, and so it is the loss of TBR.

TABLE 1. Results of the MCNP-5 calculations for a DEMO with HCPB blanket

	Without antenna	With antenna	Variation (%)
Breeding volume per blanket segment (m ³)	23.89	23.64	-1.055%
Net multiplication	1.613 0.0001	1.609 0.0001	-0.248%
Total capture (per source neutron)	1.609	1.605	-0.249%
Capture in breeding material (per source neutron)	1.321 0.0003	1.316 0.0003	-0.379%
Tritium Breeding Ratio	1.145 0.0003	1.141 0.0003	-0.349%

As one can see from Table 1, the effect of the antenna on the neutron multiplication and the TBR is small. The reason are that , the parasitic absorption in the antenna is small, the change of neutron spectrum is rather a positive effect, and the breeder volume is not reduced by much. With the assumed HCPB breeder blanket, the relative reduction of the TBR is lower than the reduced breeding volume (though the antenna sits in front, for the reduction of volume it is as if a volume in the back, the least productive, is removed). Such low impact on the TBR, together with the fact that the antenna does not need to be placed in a port, enhances the attractiveness of the ICRF and makes possible to combine ICRF with other heating methods or diagnostics that do use the equatorial ports. An interesting comparison for these results is with an equivalent void opening in the equatorial port. Taking 16 ports with 1 m x 2 m openings (32 m² in total) the loss of TBR in an HCPB blanket is 10% [2]. The effect of the complete ICRF antenna (total area of ~67 m²) is thus equivalent to a single void opening of 1.40 m² in the equatorial port.

4.2 Parametric analysis

DEMO is still in a preliminary phase and therefore it is still under development. ITER will be the key milestone with the opportunity to test and improve many features, but that also means that there is still a wide range of possibilities concerning different aspects. The results so far have shown that the antenna concept is feasible in terms of tritium self-sufficiency in the current configuration. Since the design is in a preliminary stage, it is important to do a parametric analysis to see how the loss of TBR changes due to the antenna if some of the parameters are modified. The parameters studied here are a compromise between an apparently strong dependence with the TBR on the one hand, and the ones which are more likely to change in a near future on the other hand. The objective, then, is to provide guidance as to which factor affect mostly the TBR and thus also provide guidance for further antenna design and allow to estimate the loss of TBR in a short and middle term horizon.

Blanket concept. The HCPB blanket composition in the blanket modules has been replaced first by a HCLL and then by a WCLL type mixture to study the antenna effect on the TBR for blankets with different neutronics characteristics. Table 2 shows the neutron balance for these cases. It is revealed that the strongest effect regarding the blanket concept is for the HCLL mixture, with -0.53%, but it is still low. The WCLL is in the middle of the three blanket concepts with a loss of -0.51% but closer to the HCLL. These results were actually expected since the use of the HCLL mixture results in a faster neutron spectrum and thus, as opposed to the HCPB mixture, results in an enhanced neutron out-scattering losses from the breeder and increased parasitic absorptions in the structure including the antenna. The WCLL is lower than the HCLL due to the higher moderation and absorption of water rather than helium.

TABLE 2. Variation between the reactor with and without the antenna implemented for the HCPB, HCLL and WCLL blanket concepts

	HCPB	HCLL	WCLL
Breeding volume per blanket segment (m ³)	-1.055%	-1.055%	-1.055%
Tritium Breeding Ratio	-0.349%	-0.532%	-0.507%

Covering Ratio. The covering ratio of the straps is defined as the ratio between the surface of all the straps and the projected surface of the antenna slot. The covering ratio of the antenna studied is ~72%. Due to the U-shape of the FW, the maximum covering ratio with the current antenna-shape is ~94% (see Fig. 4-b). A third calculation with a ~49% covering ratio is done to complement the sensitivity analysis (see Fig. 4-a). Results are shown in Table 3. These results reveal that the covering ratio strongly affects the loss of TBR, but even in the worst case (94% covering ratio) the loss remains low with -0.44%.

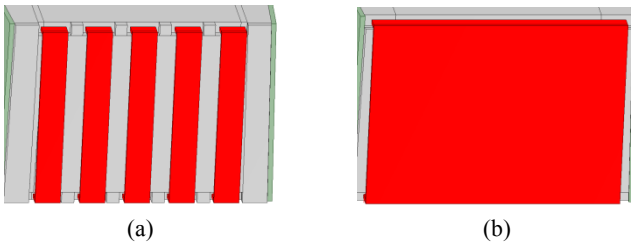

FIGURE 4. Covering ratio of the antenna straps: 49% (a) and 94% (b)

TABLE 3. Results for sensitivity analysis on the covering ratio of the antenna (DEMO HCPB)

	49% Covering Ratio		72% Covering Ratio		94% Covering Ratio		
	Without antenna	With antenna	Variation	With antenna	Variation	With antenna	Variation
Breeding volume per blanket segment (m ³)	23.890	23.641	-1.042%	23.638	-1.055%	23.637	-1.059%
Tritium Breeding Ratio	1.145	1.143	-0.175%	1.141	-0.349%	1.140	-0.437%

Blanket Depth. The depth of the antenna is the total depth of the breeding blanket that the device uses. Not all the depth is removed from the breeding blanket because there are the capacitor holes in the upper and lower part of the strap which are 5 cm deeper than the rest. The reference configuration of the antenna is 20 cm deep and that reference calculation is complemented with another one for a 40 cm deep case. It is a very conservative case, because the depth of the antenna is not very likely to be changed by that much. This very conservative case though helps to understand the effect of the depth and acts, at the same time, as the worst case. In Table 4 the results for both depths are shown.

Table 4. Results for sensitivity analysis on the depth of the antenna (DEMO HCPB)

	20 cm	40 cm
Breeding volume per blanket segment (m ³)	-1.055%	-2.817%
Tritium Breeding Ratio	-0.349%	-0.524%

The results show that when doubling the depth of the antenna up to 40 cm the loss of TBR remains low with -0.52%. The effect is less than linear.

Straps Thickness. This parameter is directly related with the parasitic absorption of neutrons because it varies the amount of material between the plasma and the breeding blanket that do not contribute to the TBR. The reference configuration of the antenna uses straps 2 cm thick and this case is complemented with two more. The first one, following the same idea as in the case of the antenna depth, using a very conservative case, a 4 cm thick straps is implemented. This case will allow us to understand the effect of the thickness on the TBR because it is the only parameter changed. The second one uses a strap with the composition of the FW. That is, 2.5 cm Eurofer plus 0.2 cm Tungsten. Results are shown in Table 5.

Table 5. Results for sensitivity analysis on the thickness of the straps (DEMO HCPB)

	2 cm	2.5 + 0.2 cm	4 cm
Breeding volume per blanket segment (m ³)	-1.055%	-1.063%	-1.067%
Tritium Breeding Ratio	-0.349%	-0.437%	-0.611%

The results show that when doubling the thickness of the straps the loss of TBR increases up to -0.61%. It is the worst case of all the parametric analysis but it is still a low value and still guarantees the TBR to stay above the unity. The case with 2.5 + 0.2 cm with the composition of the FW shows a loss of TBR of -0.44%.

Poloidal Position. The last parameter studied is the poloidal position of the antenna in the radial-poloidal cross section of the torus (see Figure 5). The final position will be defined by the functionality of the antenna and it is still being studied. Anyway, it is already set that it will be placed in the outboard upper modules, so modules 3, 4, 5 and 6 are the candidates. The reference configuration has the antenna placed in module 4.

The effect on the loss of TBR of this parameter is directly related to the Neutron Wall Loading (NWL) because the NWL is an indicator of the amount of neutrons in the region on which the antenna will have an impact. The larger the NWL, the larger the loss of TBR. Hence, module 3 is the worst case in terms of TBR, which corresponds to 0° (or 360°), and, on the outside, module 6 is the best, which corresponds to 90°. Both cases have been studied to complement the reference configuration, which places the antenna in module 4, corresponding to 40°. Results are shown in Table 6.

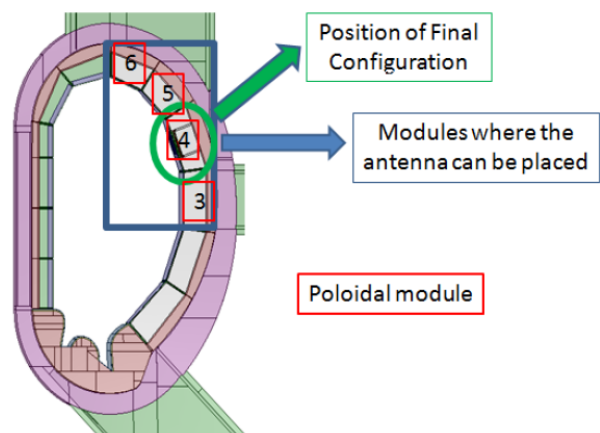
**FIGURE 5.** Poloidal availability for the reference antenna

Both cases have been studied to complement the reference configuration, which places the antenna in module 4, corresponding to 40°. Results are shown in Table 6.

Table 6. Results for sensitivity analysis on the Poloidal Position (DEMO HCPB)

	Module 3	Module 4	Module 6
Breeding volume per blanket segment (m ³)	-1.088%	-1.055%	-0.850%
Tritium Breeding Ratio	-0.379%	-0.379%	-0.303%

Of the available modules for placing the antenna, module 6 is indeed the best case with a loss on the TBR of -0.18%. The NWL is there is lowest with a value of 0.9 MW/m² (see Figure 6).

The worst case, with a NWL of 1.35 MW/m² (see Figure 6), is module 3 with a loss on the TBR of -0.35%. The interesting part is that the loss on the TBR of modules 3 and 4 is not significantly different.

The explanation for these results is the following. The antenna is less of an absorber than a corresponding thickness of the breeding blanket and therefore the flux behind the antenna is locally bigger when there is antenna, and thus the absorption is correspondingly larger. This effect smoothes the impact of the antenna the deeper the blanket is. NWL in module 4 is 1.2 MW/m² and in module 3 is 1.35 MW/m². The difference is rather small and the breeding zone is long enough to smooth the difference into a no-significant difference.

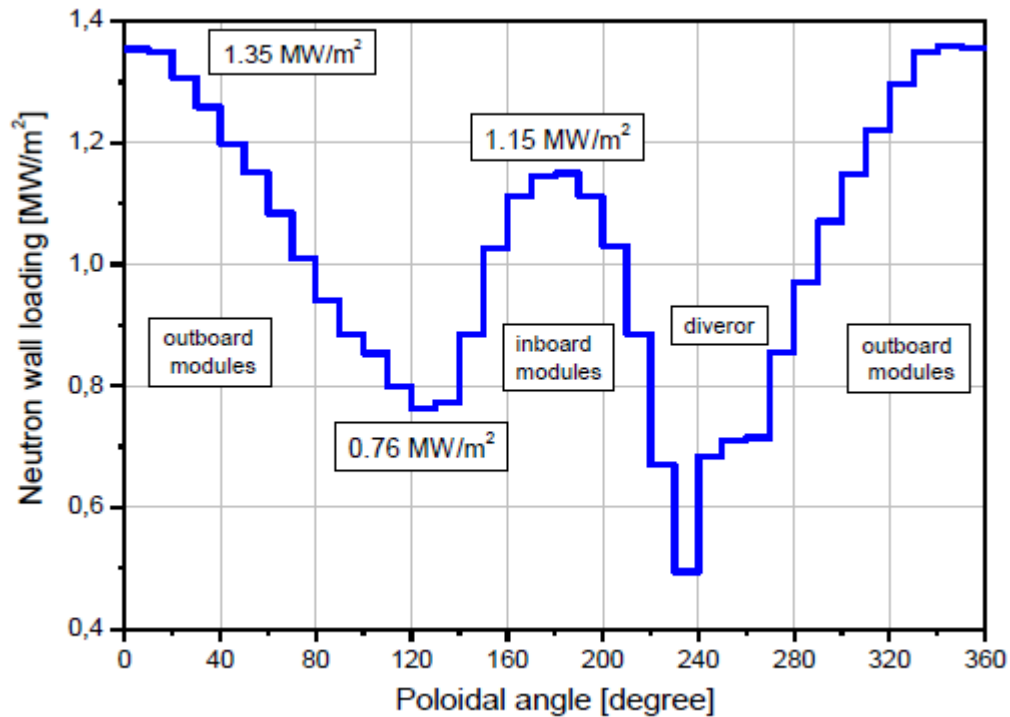
**Figure 6.** Neutron Wall Loading (NWL) in HCPB DEMO reactor [16]

CONCLUSIONS

A quantification of the loss of TBR for a distributed antenna in a DEMO reactor has been performed in this paper based on Monte Carlo calculations. The ICRF distributed antenna was shown to have only a small effect on the tritium breeding performance of DEMO. For a DEMO with HCPB blanket, there is only a reduction 0.35% of the TBR, which is equivalent to a void port opening on the equatorial plane of 1.4 m². The reduction is bigger for the HCLL blanket concept (0.53%) than for the HCPB (0.35%). The TBR reduction strongly depends on the covering ratio of the antenna, but is always below 0.44%. The reduction of the TBR when doubling the depth of the antenna up to 40 cm is -0.52%. The thickness of the straps has largest impact on the TBR and increases the loss up to -0.61% with a thickness of 4 cm and up to -0.44% when implementing a mixed composition of 2.5 cm He-cooled Eurofer + 0.2 cm W, the composition of the FW. Finally, the TBR goes from -0.35% in the equatorial port to -0.18% in the upper port, the best and worst cases respectively for the poloidal position of the antenna.

The low results show that the tritium self-sufficiency will not be a fundamental problem in the development of a distributed, in blanket ICRF antenna for DEMO.

ACKNOWLEDGMENTS

This work has been carried out within the framework of the EUROfusion Consortium and has received funding from the Euratom research and training programme 2014-2018 under grant agreement No 633053. The views and opinions expressed herein do not necessarily reflect those of the European Commission.

REFERENCES

1. G. Federici, R. Kemp, D. Ward, C. Bachmann, T. Franke et al, *Overview of EU DEMO design activities*, Fus. Eng. Des. 89(2014), 882-889
2. U. Fischer, *Neutronics Requirements for a DEMO Fusion Power Plant*, *Fusion Eng. Design* (2015)- DOI: 10.1016/j.fusengdes.2015.02.029
3. G. Bosia, "Low power density Ion Cyclotron Arrays for Fusion Reactors" *Fusion Engineering and Design*, 92(2015), 8-15
4. Li Puma, A. et al. *Design and development of DEMO blanket concepts in Europe*. 1st IAEA DEMO Programme Workshop, UCLA, October 2012.
5. U. Fischer, *Neutronics R&D Efforts in Support of the European Breeder Blanket Development Programme*- DOI: 10.1088/0029-5515/49/6/065009
6. X-5 Monte Carlo Team, MCNP-A General Monte Carlo N-Particle Transport Code (Version 5, Vol. I), Report LA-UR-03-1987, 24 April 2003 (Revised 10/3/05).
7. D.L. Aldama, A. Trkov, FENDL-2.1: update of an evaluated nuclear data library for fusion applications, Report INDC(NDS)-467, December 2004.
8. L.V. Boccaccini, et al., *Materials and design of the European DEMO blankets*, *Journal of Nuclear Materials* 329–333 (2004) 148–155
9. L.V. Boccaccini, *Design And Development of Demo Blanket Concepts in Europe*, 1st IAEA DEMO Programme Workshop, UCLA, 15-18 Oct. 2012
10. P. Pereslavytsev, et al., Neutronic analyses of the HCPB DEMO reactor using a consistent integral approach, *Fusion Eng. Des.* (2014), <http://dx.doi.org/10.1016/j.fusengdes.2013.12.019>
11. D. Iglesias, et al., *Blanket Segment Remote Maintenance*, Report for Task Agreement WP13/DAS07/T05
12. Ricardo Ragona, ERM/KMS Brussels, personal communication (2015)
13. 3D Modeling Software for Engineering SpaceClaim, <http://www.spaceclaim.com>
14. L. Lu, U. Fischer, P. Pereslavytsev, Improved Algorithm and Advanced Features for the CAD to MC Conversion Tool McCad, *Fusion Eng. and Design* 89(2014), 1885–1888.
15. X-5 Monte Carlo Team, *MCNP-A General Monte Carlo N-Particle Transport Code, Version 5, Volume I: Overview and theory, page 2.85*, April 24, 2003 (Revised 02/01/2008)
16. PERESLAVTSEV, P. *Nuclear analysis of breeder blanket for HCPB DEMO*. Neutronics coordination meeting. December 2014b.