



EUROfusion

EUROFUSION WPHCD-CP(16) 15081

G. Grossetti et al.

DEMO Port Plug design and integration studies

Preprint of Paper to be submitted for publication in
Proceedings of 26th IAEA Fusion Energy Conference



This work has been carried out within the framework of the EUROfusion Consortium and has received funding from the Euratom research and training programme 2014-2018 under grant agreement No 633053. The views and opinions expressed herein do not necessarily reflect those of the European Commission.

This document is intended for publication in the open literature. It is made available on the clear understanding that it may not be further circulated and extracts or references may not be published prior to publication of the original when applicable, or without the consent of the Publications Officer, EUROfusion Programme Management Unit, Culham Science Centre, Abingdon, Oxon, OX14 3DB, UK or e-mail Publications.Officer@euro-fusion.org

Enquiries about Copyright and reproduction should be addressed to the Publications Officer, EUROfusion Programme Management Unit, Culham Science Centre, Abingdon, Oxon, OX14 3DB, UK or e-mail Publications.Officer@euro-fusion.org

The contents of this preprint and all other EUROfusion Preprints, Reports and Conference Papers are available to view online free at <http://www.euro-fusionscipub.org>. This site has full search facilities and e-mail alert options. In the JET specific papers the diagrams contained within the PDFs on this site are hyperlinked

DEMO Port Plug Design and Integration Studies

G. Grossetti 1), L.V. Boccaccini 1), F. Cismondi 1, 2), U. Fischer 1), T. Franke 2, 5), G. Granucci 3), F. Hernández 1), D. Strauß 1), M. Q. Tran 4), A. Vaccaro 1)

1) Karlsruhe Institute of Technology (KIT), Karlsruhe, Germany

2) EUROfusion Programme Management Unit (PMU), Garching, Germany

3) Institute of Plasma Physics (IFP), Milan, Italy

4) Swiss Plasma Center (SPC), Lausanne, Switzerland

5) Max-Planck-Institut für Plasmaphysik (IPP), Garching, Germany

Author's e-mail: giovanni.grossetti@kit.edu

Abstract. The EUROfusion Consortium established in 2014 and composed by European Fusion Laboratories, and in particular the Power Plant Physics and Technology department aims to develop a conceptual design for the Fusion DEMONstration Power Plant, DEMO. With respect to present experimental machines and ITER, the main goals of DEMO are to produce electricity continuously for a period of about 2 hours, with a net electrical power output of a few hundreds of MW, and to allow Tritium self-sufficient breeding with an adequately high margin in order to guarantee its planned operational schedule, including all planned maintenance intervals. This will eliminate the need to import tritium fuel from external sources during operations. In order to achieve these goals, extensive engineering efforts as well as physics studies are required to develop a design that can ensure a high level of plant reliability and availability. In particular, interfaces between systems must be addressed at a very early phase of the project, in order to proceed consistently. In this paper we present a preliminary design and integration study, based on physics assessments for the EU DEMO1 Baseline 2015 with an Aspect Ratio = 3.1 and 18 Toroidal Field Coils, for the DEMO port plugs. These aim to host systems like Electron Cyclotron Heating launchers currently developed within the Work Package Heating and Current Drive that need an external radial access to the plasma and through in-vessel systems like the breeder blanket. A similar approach shown here could be in principle followed by other systems, e.g. other heating and current drive systems or diagnostics. The work addresses the interfaces between the port plug and the blanket on the specific example of the Helium-Cooled Pebble Bed which is one of four breeding blanket concepts under investigation in Europe within the Power Plant Physics and Technology Programme: the required openings will be evaluated in terms of their impact onto the blanket segments thermo-mechanical and nuclear design considering mechanical integration aspects but also their impact on Tritium Breeding Ratio. Since DEMO is still in a pre-conceptual phase, the same methodology is applicable to the other three blanket concepts, as well.

1. Introduction

In 2014, 29 Research Units and Universities from 26 European countries plus Switzerland, signed the EUROfusion consortium agreement for the *Development of Fusion Energy* [1] on behalf of Euratom. Within this framework, the Power Plant Physics and Technology department (PPPT) focuses its effort for the development of a pre-conceptual design for the DEMONstration Fusion Power Plant, DEMO [2], [3]. Due to the high complexity of the system, extensive engineering efforts as well as physics studies are required for developing a consistent design that can guarantee high level of reliability and availability [4], mitigating the risks associated to moving targets and interfaces.

Following what reported in [5], in this paper we present a preliminary design and integration study for port plugs dedicated to systems that require an external radial access to the plasma, e.g. Electron Cyclotron (EC) launchers developed by the PPPT Work Package Heating and Current Drive (WPHCD) [6] and devoted to provide localized heating and current drive [7], other heating and current drive systems or diagnostics, all interfacing with in-vessel systems like the breeder blanket. The work is based on physics assessments for the EU DEMO1 baseline 2015 [8], a tokamak with an Aspect Ratio (AR) = 3.1 and 18 Toroidal Field (TF) Coils (see figure 1 for the main parameters and a cut out of the machine).

Parameter		Value
Geometry	R_0	9.072 m
	a	2.927 m
	AR	3.1
	No. of TF Coils	18
Physics	I_p	19.6 MA
	B_T at R_0	5.667 T
	$\langle T_e \rangle$ (T_0)	13.07 (27.4) keV
	$\langle n_e \rangle$ (n_0)	7.983e+19 (1.01e+20) m ⁻³
Power flow	Thermal power	2389.1 MW
	Fusion power	2037 MW
	Net electrical power	500 MW

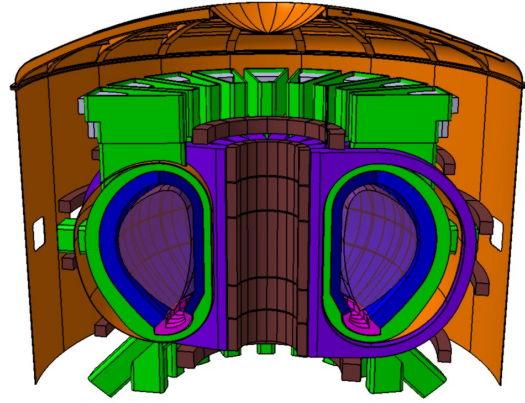

Fig. 1: Main parameters (left) & Tokamak complex cut out (right) for the EU DEMO1 baseline 2015 with AR = 3.1 and 18 TF Coils. The value for thermal power refers to a study performed for HCPB blanket.

2. Port Plug Integration in the Breeding Blanket

In this first phase of the integration studies, we have considered the Helium-Cooled Pebble Bed (HCPB) blanket concept, using lithium ceramic pebbles as breeder material and beryllium as neutron multiplier. This is one of the four breeding blanket (BB) concepts under investigation in Europe within the PPPT Programme, the others being the Helium Cooled Lithium Lead (HCLL) with the Pb–Li eutectic alloy acting both as breeder and neutron multiplier, the Water Cooled Lithium Lead (WCLL) and the Dual Cooled Lithium Lead (DCLL). For an all-encompassing overview of the four blanket concept, see [9].

Since the project is in a pre-conceptual phase, the same methodology implemented in this work is applicable not only to the HCPB, but also to the other three blanket concepts.

2.1. The Helium Cooled Pebble Bed Concept

The EU DEMO baseline HCPB BB concept (see figure 2-a, -b, -c, -d) is based on the so-called multi-module segment (MMS) architecture. In its latest design [10] the MMS consists of 7 outboard (OB) and 7 inboard (IB) BB modules (figure 2-c).

Each HCPB BB module (figure 2-a) is composed by a box formed by a U-shaped First Wall (FW), 2 caps and a backplate. These 4 components form the volume of the so-called breeder zone (BZ). The BZ itself is arranged as a periodic sandwich-like structure of a breeder ceramic (lithium orthosilicate, Li_4SiO_4) and a neutron multiplier (beryllium), separated both by cooling plates (CP). These functional materials are in form of pebble beds (polydisperse pebbles for the Li_4SiO_4 with pebble diameters ranging from 0.2 mm to 0.6 mm and monosize pebbles for the Be of $\varnothing 1$ mm), where a purge gas mixture of He + 0.1wt.%H₂ flows sweeping the beds and extracting in this way the tritium produced in the BZ. The FW, caps and CP are actively cooled with He at a pressure of 8 MPa, entering the BB at 300 °C and leaving it at 500 °C. Each module box is attached to the Back Supporting Structure (BSS), which serves as coolant and purge gas manifold, as well as structural support for the BB modules (figure 2-c). Figure 2-d shows the arrangement of the cooling and purge gas pipework required for the functioning of a toroidal 20° DEMO sector of the HCPB BB system.

2.2. Port Plug Architectures

Currently, different port plug concepts as well as their integration schemes are under assessment. The selection of a specific architecture shall be based on aspects like

performances, mechanical integration, impact on TBR [11], [12] and maintainability. The port plug is cantilevered off the flange that interfaces the port.

Due to the high neutron flux (up to 50dpa in EUROFER at the FW outboard mid-plane), labyrinths are required. Their design shall allow sufficiently large gaps for accounting thermal expansions, as well as movements of port plugs due to forces by eddy currents resulting from plasma off-normal behavior, like disruptions or vertical displacement events (VDEs).

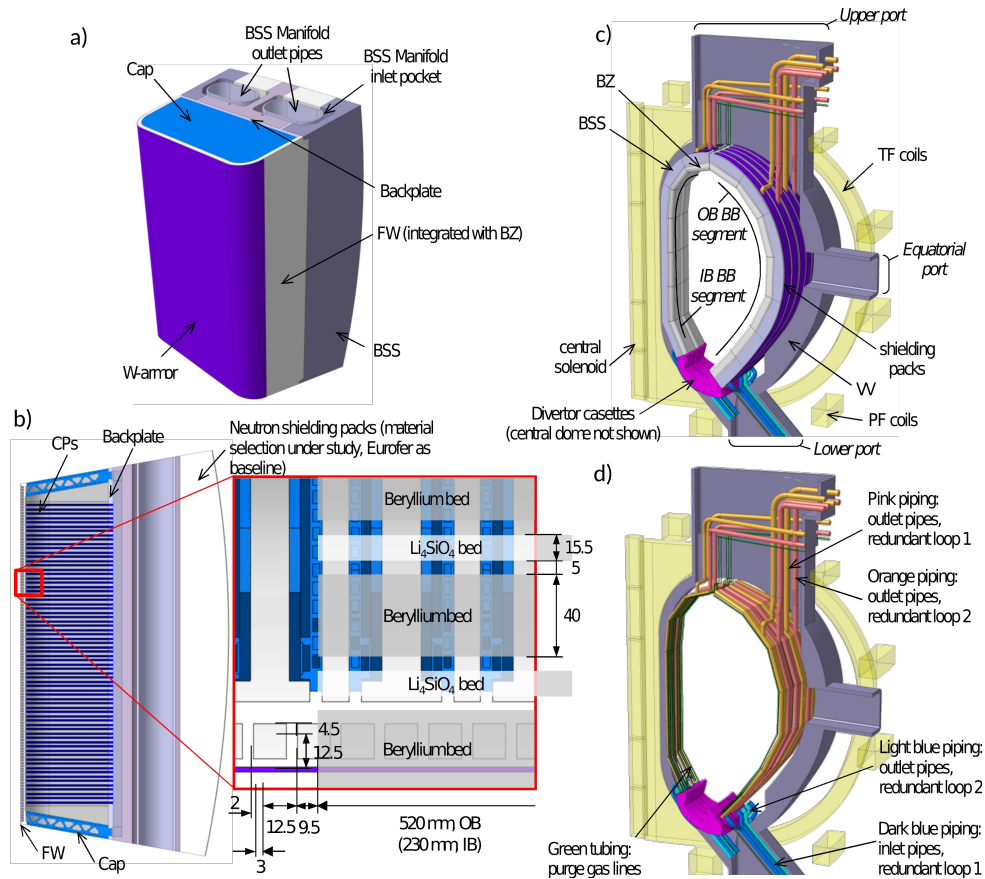

Fig. 2-a, -b, -c, -d: HCPB 2015 Breeding Blanket concept. -a: isometric view of the equatorial OB module OB4; -b: section cut of the OB4 and detail of the BZ; -c: isometric view of a 20° DEMO sector with the baseline HCPB-I; -d: detail of the coolant and purge gas pipework of the baseline HCPB-I.

The options currently under investigation are applied to the equatorial port plugs (EPP) and foresee different integration schemes with the OB-MMS, namely a Blanket Separated Design (BSD) and a Blanket Integrated Design (BID). A similar approach can be applied for the integration of vertical port plugs, as well as for upper port plug *à la ITER* [13].

In both concepts, the port plug system forming the structural component of the launcher assembly is composed by a main frame (MF), two shields and a plug flange. A closure plate (CP) at the port plug back end will also be included in a second phase of the assessment. In the BSD concept the port plug stops behind the BSS. Cut outs in the OB-MMS shall be included to provide a radial access for the electron cyclotron waves. The gaps between the port and port plug have been assumed to be 60 mm (lateral and upper) and 100 mm (lower), in order to give room for remote handling equipment like the one described in section 4. In this configuration the port plug front end (FE) has a minimum gap of 20 mm with the central OB-MMS and all the waveguides are kept within the port plug structure. For the BSD concept, two different configurations for the mm-wave system when using a Remote Steering Antenna (RSA) concept [14] are presently considered. It is important to underline that RSA is

one of the possible launcher configurations assessed in the WPHCD, the other based on truncated waveguides and multipurpose multi-frequency gyrotrons [15], [16].

The first RSA configuration, hereafter called BSD-cfg1 (figure 3-a), affects the design of 2 OB-MMS per sector where an EPP is included. Assuming (as indicated in [17]) 5 EPP, this will lead to 10 OB-MMS impacted. The two OB-MMSs per sector affected (central and right one looking at the plasma from the Port Plug) are cut into three sections (see figure 3-b), two of which contains breeding modules and one is made by a non-breeding block containing the openings.

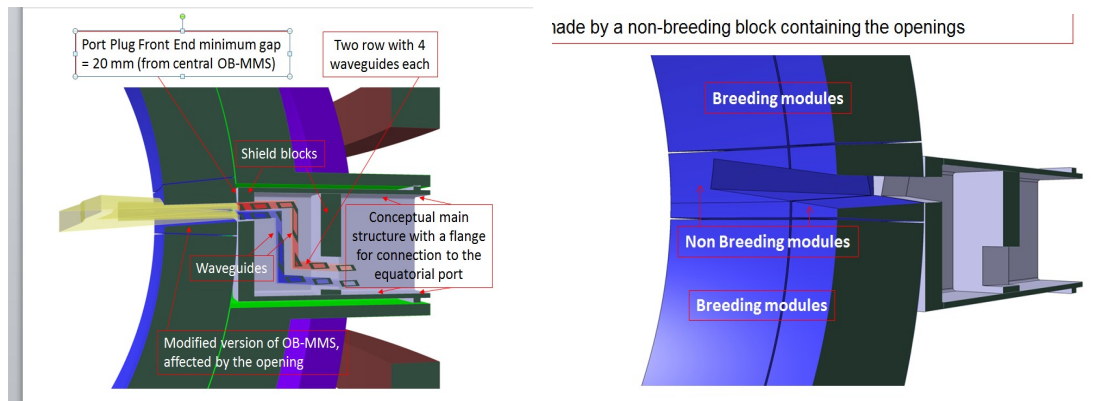

Fig. 3: -a (left) Cutout of the EPP (BSD-cfg1 concept); -b (right) blankets affected by the openings.

In figure 4 –a, and –b are reported a top view of the BSD-cfg2, hosting a vertical stacked array of 8 truncated squared waveguides and the blanket opening. In this configuration the OB-MMS affected is one (the right one with respect to the central one, when looking from top). The cut into the BSS on the OB-MMS is rather small and it is expected not to compromise its structural integrity. This solution might be relevant for the remote maintenance scheme foreseen for the Breeding Blanket system, i.e. the Vertical Maintenance Scheme (VMS). The structural components (shields, main frame and flange), as well as gaps, are kept identical to the ones defined for BSD-cfg1.

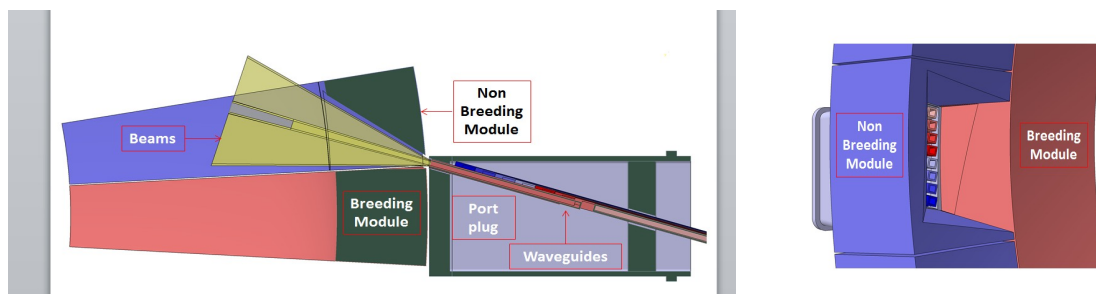

Fig. 4: -a (left) top view of the EPP (BSD-cfg2 concept) and -b (right) blanket affected by the openings.

In the BID concept (figure 5–a and –b) the port plug extends through to the first wall, penetrating the central OB-MMS. In this first phase of the study, this is cut into two independent parts containing breeding modules. In this configuration the two breeding sections of the Central OB-MMS need that the inlet and outlet of the cooling channels are located either in the vertical (for the upper section of the breeding module) or in the lower port (for the lower section of the breeding module). Depending on the system which is hosted by the port plug, design with smaller impact on the OB-MMS will be study in the future.

Similarly to the breeding modules, the FE will need to be cooled. This aspect has not been assessed yet however, as first concept one can consider the solution reported in [18] applied for the ITER ECH&CD Upper port Plug.

As we are still in an early phase of the integration studies, precise evaluation of the impact on Tritium Breeding Ratio (TBR) by port plugs devoted to host EC launchers is so far not possible. However, an upper limit to the TBR impact can be estimated by removing the contribution of the breeding modules geometrically affected by the presence of the port plugs. This approach, although not fully accurate, is valid since values meet the Heating and Current Drive (H&CD) design targets (total TBR 1.263 for HCPB, design targets: DEMO >1.1, H&CD >0.04 [19]). The breeding modules affected by the integration of EPPs are the ones placed along the equatorial plane and in front of the equatorial port ducts: there are 3 modules per sector. Each of the modules is contributing by a factor 0.0035. Assuming 5 EPPs and up to 10 breeding modules affected, the total impact will be less than 0.035.

3. Electromagnetic and Structural Analyses

A set of preliminary analyses of the BSD concept have been run to compare its two configurations. The analyses consist of EM simulations of a 70 ms fast plasma disruption, for calculation of Lorentz's forces and moments, and subsequent structural analyses of the plug. For sake of simplicity, the analyses have been run in the same fashion as in reported in [20] that is assuming no ferromagnetic properties and modelling the plasma using an elliptic cross-section and quadratic formulation for the current density distribution. As far as the Central Solenoid, the Poloidal Field and Toroidal Field coils are concerned, all of the three possible scenarios provided in plasma equilibrium description document, i.e. pre-magnetization (Premag), start of flat top (SOF) and end of flat top (EOF), have been implemented and the results are here compared. The results of the EM analyses have shown no significant difference between the three equilibrium scenarios, as shown in figure 6 where the moments acting on both configurations of the port plug are compared. The current density induced in the plug forms loops that lay mainly on the horizontal plane and therefore the dominant load is a radial moment (torque aligned to the plug's axis).

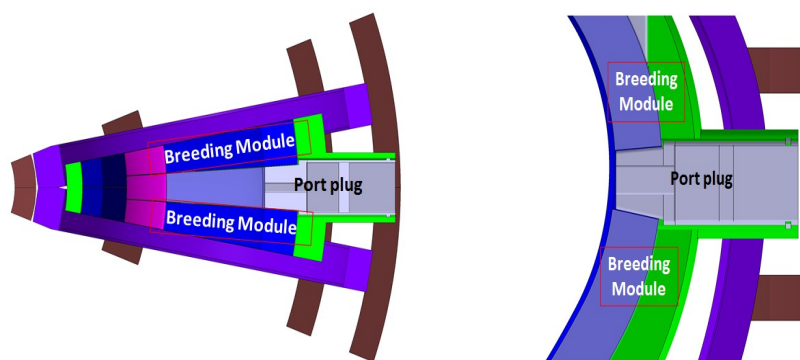

Fig. 5: Top view (left) and poloidal view (right) of the BID concept, integrated into the blanket system

The different sizes and orientations of the front openings in the port plug have shown to have no influence on the overall behavior of the structure, the magnitude of the stresses being in any case less than 20 MPa (figure 7). This is the obvious advantage of having the entire plug placed behind the blanket segments that, in turn, screen it from the effects of the electromagnetic transients.

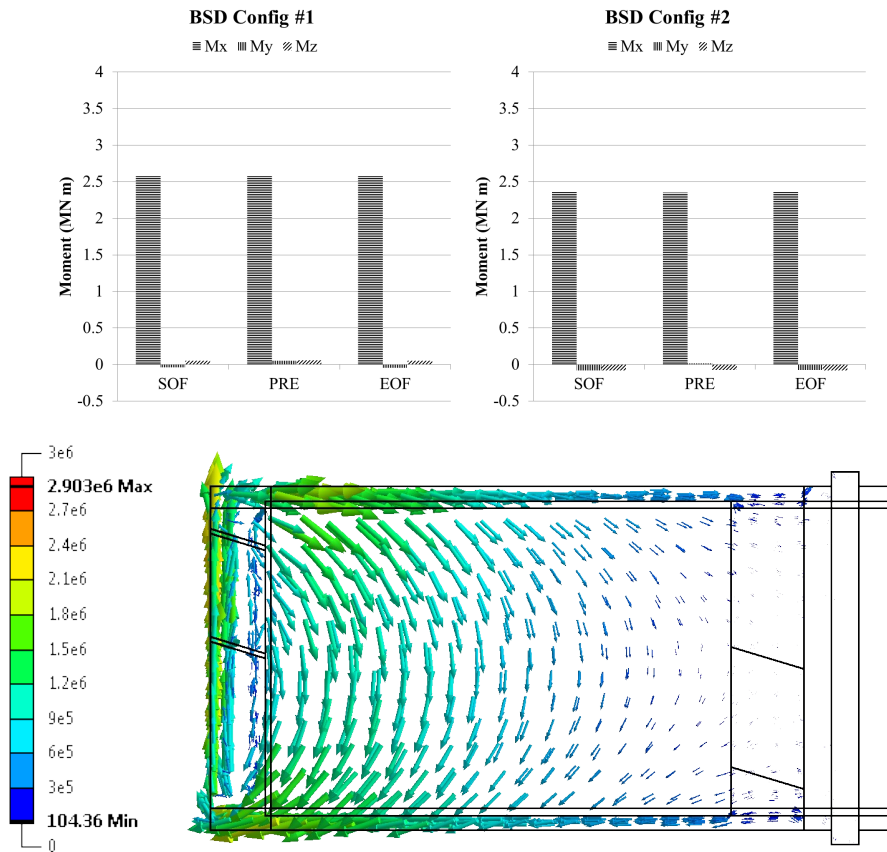

Fig. 6: EM loads (moments) acting on the two configurations of the EPP (top) and eddy currents on configuration 1 (bottom) during a 70 ms plasma disruption.

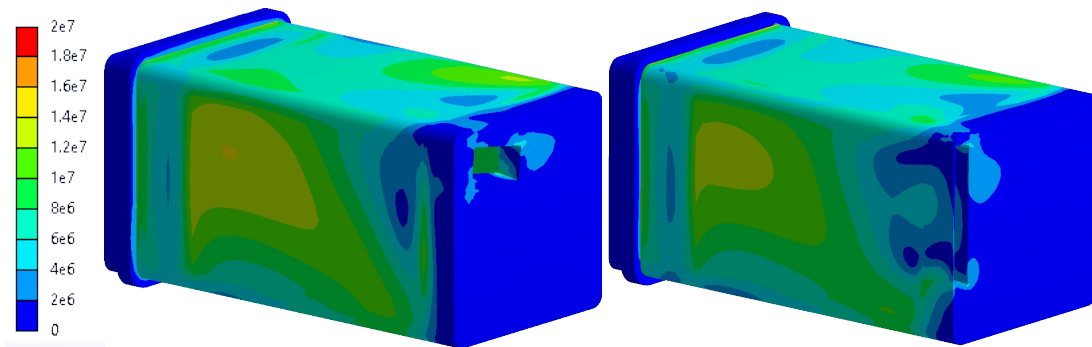

Fig. 7: Von Mises Stress distribution (MPa) in the configuration 1 (left) and 2 (right) of the BSD EPP during a 70 ms plasma disruption.

4. Port Plug Maintainability

One of the key issues in designing a prototype of a fusion power plant like DEMO is represented by maintainability of in-vessel systems. Therefore, the integration of port plugs with the blanket shall take into account maintainability considerations from the very beginning of the design assessment for both the port plug and the blanket systems [21], since large openings into the blanket may drive towards modifications of the Vertical Maintenance scheme [22]. Here we present a concept design of two removable rails given with ceramic wheels aiming to support the installation and removal of Port Plugs. The use of ceramic is justified by the fact that this material have some attractive properties compared to metals and polymers, e.g. low electrical and thermal conductivity, high strength and wear resistance,

which make them used as roller bearings in nuclear fusion technology applications. However, characteristics like brittleness and side effects like dust production need to be carefully addressed before implementing the design beyond this conceptual level. As shown in figure 8 the rails foresee a modular design, composed by four modules, each one having seven ceramic wheels in a “3 to 4” wheel distribution. With this configuration there are three wheels on the top side which realize the connection to the plug and four on the bottom side which are in contact with the port. The modules are connected by steel plates that provide supports for lifting systems.

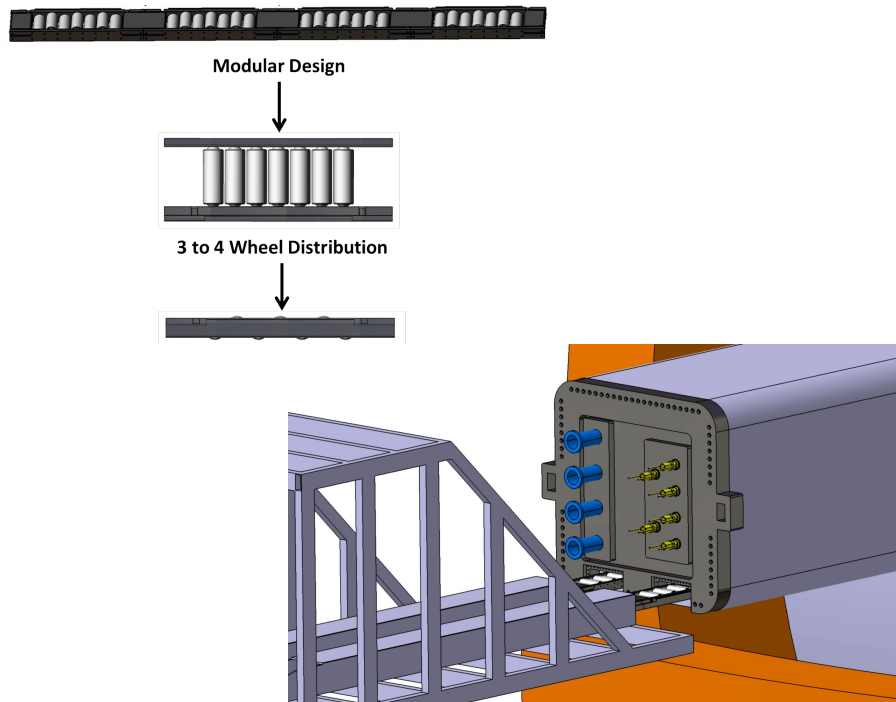

Figure 8: Concept for a possible rail system for the insertion and removal of EPPs

5. Summary

The development of a complex project like DEMO requires careful design and integration studies, in order to evaluate the interdependencies and interfaces among the different parts of the DEMO system. The study we have here presented is the first step in approaching the definition of integrated solution for port plugs, particularly for the required penetrations on the breeding blanket system.

The methodology we have shown here, that consists in assessing different possible configurations satisfying the set of functions that the system *port plug* shall achieve, is based on a version of DEMO which is presently available during the pre-conceptual phase. This step is preparatory in order to run in a later phase of the assessment, system analysis and synthesis and for performing tradeoffs on the different design options leading to a selection/descoping of concept(s) by the end of the conceptual phase.

The two port plug architectures presented in this paper, BSD and BID, both promising with respect to the impact on TBR will be further studied and developed, refining their design according to the progress of interfaces. In addition to the tradeoffs on the structural components, also assessments on different solutions and integration schemes for systems to be hosted into port plugs such as different concepts for the EC launchers (e.g. including systems compatible with step-tunable gyrotrons), other additional heating systems and diagnostics will need to be run in parallel for granting design consistency.

Acknowledgment

This work has been carried out within the framework of the EUROfusion Consortium and has received funding from the EURATOM research and training programme 2014-2018 under grant agreement No 633053. The views and opinions expressed herein do not necessarily reflect those of the European Commission.

References

- [1] F. ROMANELLI et al., “A roadmap to the realization of fusion energy” EFDA pub. 2012,
<https://www.euro-fusion.org/wpcms/wp-content/uploads/2013/01/JG12.356-web.pdf>
- [2] G. FEDERICI et al., “Overview of the design approach and prioritization of R&D activities towards an EU DEMO”, in press on Fus. Eng. & Des. (2015).
- [3] M. COLEMAN et al., “On the EU approach for DEMO architecture exploration and dealing uncertainties”, in press on Fus. Eng. & Des. (2016)
- [4] C. BACHMAN et al., “Issues and strategies for DEMO in-vessel component integration”, in press on Fus. Eng. & Des. (2015)
- [5] G. GROSSETTI et al., “DEMO: Heating and Current Drive system integration with blanket system”, Proc. 25th Symposium on Fusion Engineering, June 10 – 14, 2013 San Francisco (USA)
- [6] M. Q. TRAN et al., “EU DEMO 2015 Heating and Current Drive: Physics and Technology”, this conference
- [7] R. WENNINGER et al., “Advances in the physics basis for the European DEMO design”, Nucl. Fusion **55** (2015) 063003
- [8] B. MESZAROS et al., “Definition of the basic DEMO tokamak geometry based on system code studies”, Fus. Eng. & Des. 98-99 (2015) 1556-1560
- [9] L. V. BOCCACCINI et al., “Objectives and status of the EUROfusion DEMO blanket studies”, in press on Fus. Eng. & Des. (2016)
- [10] F. HERNANDEZ et al., A new HCPB breeding blanket for the EU DEMO based on an integrated First Wall: evolution, rationale and preliminary performances, Proceedings of the 29th Symposium on Fusion Technology, September 5-9, Prague (2016)
- [11] P. PERESLAVTSEV et al., Fus. Eng. & Des. **89** (2014) 1979–1983
- [12] U. FISCHER et al., “Neutronic performance issues of the breeding blanket options for the European DEMO fusion power plant”, in press on Fus. Eng. & Des. (2016)
- [13] G. GROSSETTI et al., “Electron Cyclotron waves for Current Drive and Neo-Classical Tearing Mode mitigation in a DEMO machine”, Conf. proc. 40th IRMMW-THz, August 23-28, 2015, Hong Kong (China)
- [14] G. GRANUCCI et al., “Conceptual design of the DEMO EC-system: main developments and R&D achievements”, this conference
- [15] H. ZOHN and M. THUMM. “On the use of step-tuneable gyrotrons in ITER”. J. of Phys.: Conf. Series, 25, 274-282 (2005).
- [16] J. FRANCK et al., “Multi-frequency design of a 2 MW coaxial-cavity gyrotron for DEMO”, Conf. proc. 40th IRMMW-THz, August 23-28, 2015, Hong Kong (China).
- [17] S. GARAVAGLIA et al., “Progress in conceptual design of DEMO EC System”, Proc. 19th Joint workshop on Electron Cyclotron Emission (ECE) and Electron Cyclotron Resonance heating (ECRH), April 04 – 07, 2016 Gandhinagar (India)
- [18] P. SPÄH et al., “Cooling design analysis of the ITER EC Upper launcher”, Conf. proc. 26th Symposium on Fusion Engineering (SOFE), May 31 – June 4, 2015, Austin (USA)

- [19] T. FRANKE et al. “Heating & Current Drive Efficiencies, TBR and RAMI considerations for DEMO”, submitted to *Fus. Eng. & Des.*
- [20] I. A. MAIONE and A. VACCARO, “Parametric analysis of EM loads acting on demo vertical segments with respect to module's dimension”, Proc. of the 25th Symposium on Fusion Engineering, 10–14 June 2013, San Francisco, (USA)
- [21] M. MITTWOLLEN et al., “DEMO – Initiation of remote maintenance requirements”, Proc. 25th Symposium on Fusion Engineering, June 10 – 14, 2013 San Francisco (USA)
- [22] A. LOVING *et al.* *Fus. Eng. & Des.* **89** (2014), Issues 9-10