



**EUROfusion**

WPEDU-PR(18) 20225

ADL Hancock et al.

# **Testing Advanced Divertor Concepts for Fusion Power Plants Using a Small High Heat Flux Facility**

Preprint of Paper to be submitted for publication in  
Journal of Testing and Evaluation



This work has been carried out within the framework of the EUROfusion Consortium and has received funding from the Euratom research and training programme 2014-2018 under grant agreement No 633053. The views and opinions expressed herein do not necessarily reflect those of the European Commission.

This document is intended for publication in the open literature. It is made available on the clear understanding that it may not be further circulated and extracts or references may not be published prior to publication of the original when applicable, or without the consent of the Publications Officer, EUROfusion Programme Management Unit, Culham Science Centre, Abingdon, Oxon, OX14 3DB, UK or e-mail [Publications.Officer@euro-fusion.org](mailto:Publications.Officer@euro-fusion.org)

Enquiries about Copyright and reproduction should be addressed to the Publications Officer, EUROfusion Programme Management Unit, Culham Science Centre, Abingdon, Oxon, OX14 3DB, UK or e-mail [Publications.Officer@euro-fusion.org](mailto:Publications.Officer@euro-fusion.org)

The contents of this preprint and all other EUROfusion Preprints, Reports and Conference Papers are available to view online free at <http://www.euro-fusionscipub.org>. This site has full search facilities and e-mail alert options. In the JET specific papers the diagrams contained within the PDFs on this site are hyperlinked

# Testing Advanced Divertor Concepts for Fusion Power Plants Using a Small High Heat Flux Facility

David Hancock<sup>a,b,\*</sup>, David Homfray<sup>a</sup>, Michael Porton<sup>a</sup>, Iain Todd<sup>b</sup>, Brad Wynne<sup>a,b</sup>, Rob Bamber<sup>a</sup>, Kieran Flinders<sup>a</sup>, Paul Jepson<sup>a</sup>, Heather Lewtas<sup>a</sup>, Harry Robinson<sup>a</sup>

<sup>a</sup>United Kingdom Atomic Energy Authority, Culham Science Centre, Abingdon, Oxon, OX14 3DB

<sup>b</sup>University of Sheffield, Department of Materials Science and Engineering, Sir Robert Hadfield Building, Mappin Street, Sheffield, S1 3JD

---

## Abstract

The development of improved designs for components which will be subject to high heat fluxes has been identified as a critical challenge for the realisation of commercial fusion power. This paper presents details of a facility which allows early verification of thermofluid and thermomechanical performance of prototype components and enables comparison between concepts and manufacturing methods. This provides a validation step between in silico design and analysis and high-cost particle beam testing which is the usual qualification method for fusion high heat flux components.

As part of AMAZE, an European FP7 project aiming to grow confidence in additive manufacturing, prototype divertor structural and armour elements were manufactured in copper and tungsten respectively using both conventional machining and a range of AM techniques. In order to assess the comparative performance of these conventional and AM prototypes, a small high heat flux facility has been designed and built at the Culham Centre for Fusion Energy in Oxfordshire. This facility, HIVE (Heating by Induction to Verify Extremes), consists of a 45 kW high frequency induction heating system, 200 °C, 20 bar closed-loop water cooling, a 500 mm diameter vacuum vessel, and bespoke control and instrumentation system. Water flow, temperature, and pressure transducers provide calorimetry and thermofluid performance measurement, while embedded thermocouples and thermal imagery allow comparisons with finite element thermal models and between samples.

The design and key features of this facility and the results of testing carried out under AMAZE are presented, highlighting both the promise of AM as a manufacturing technique for fusion high heat flux components and the value of these low-cost, short-timescale tests in initial down-selection and preliminary validation of concepts. In addition, future plans for HIVE are presented, including other test campaigns post-AMAZE and associated diagnostic and operational upgrades.

*Keywords:* additive manufacturing, fusion, high heat flux, divertor, DEMO, testing

---

## 1. Introduction

The development of improved designs for components with higher heat flux handling capability, longer in-service lifetimes, and better thermal efficiency has been identified as a critical challenge for the realisation of commercial fusion power [1]. To meet this need, concepts have been developed for the divertor target which range from incremental modifications to the baseline solution to be used for the ITER tokamak experiment currently under construction\*, employing a CuCrZr pipe and W monoblock [2], to more novel concepts employing additive manufacturing (AM) of refractory metals as structural and armour materials and employing high temperature coolants [3]. This broad approach to concept generation ranging from conservative to advanced gives breadth to the community and balances the risks associated with novel designs with the potential for significant performance enhancement.

The qualification process for these concepts must involve representative testing. Typically, this includes high heat flux testing using an electron or ion beam facility, which simulates the particle fluxes to which the divertor is subjected in a fusion device [e.g. [4, 5, 6, 7]] and include water or gas cooling at high pressure and temperature. These facilities provide detailed data about failure mechanisms and damage due to plasma-surface interactions, include thermal imagery to confirm performance and integrity, and have been used to qualify by experiment components for which design by analysis has not been feasible. The rigour and scale of these tests, however comes at a significant cost and this inevitably impacts the scope for innovation and in some cases the ability to undertake large numbers of experiments to improve statistical significance.

This paper presents the details of the HIVE facility (Heating by Induction to Verify Extremes), designed to allow early verification of thermofluid and thermomechanical performance of high heat flux components and to allow comparison between concepts and manufacturing methods, rather than focussing on full component

---

\*Corresponding Author

Email address: david.hancock@ukaea.uk (David Hancock)

\*<https://www.iter.org>

qualification or plasma surface interactions. This approach is particularly attractive when investigating concepts produced via additive manufacturing as it allows a rapid evaluation of concepts which can include novel features or materials and can quantitatively measure the impact of geometric or material property variation. In addition, the ability to carry out high numbers of thermal cycles allows the investigation of thermomechanically induced damage mechanisms, including the potential to carry out interrupted testing to explore the evolution of this damage. The primary goals of HIVE are as follows:

- to test components under fusion relevant surface heat fluxes in vacuum.
- to provide a high degree of flexibility of component architecture.
- to provide verification of the feasibility of concept designs which use advanced manufacturing processes — specifically to compare the thermal and mechanical behaviour of cooled components to modelling and to compare results from novel and conventionally manufactured components.
- to minimise facility capital and operational costs while allowing scope for future upgrades.

HIVE’s initial function has been to assess the comparative performance of conventionally manufactured and AM prototypes produced as part of the AMAZE project<sup>†</sup>. This was a European FP7 project involving a wide range of industrial and academic partners aiming to grow confidence in AM. Prototype divertor structural elements were manufactured in copper using both conventional machining and electron beam melting (EBM), a powder based additive layer process. Tungsten armour tiles were also manufactured using laser powder bed and wire-arc (WAAM) techniques, with the aim of comparing their performance to rolled plate.

Details of the design and key features of the facility are given below as well as the results of testing carried out under AMAZE. This highlights both the promise of AM as a manufacturing technique for fusion high heat flux components and the value of these low-cost, short-timescale tests in initial down-selection and preliminary validation of concepts. In addition, future plans for HIVE are presented, including other test campaigns post-AMAZE and associated diagnostic and operational upgrades.

## 2. The HIVE facility

### 2.1. Overview

Central to the design rationale of HIVE has been the desire to employ commercial off-the-shelf systems as far

as possible. This is to ensure robustness of performance and reliability, to reduce design overheads, and to provide access to ongoing maintenance and repair. Furthermore, capacity has been included wherever possible for upgrade and extension to allow increases in performance or alterations in usage in the future. Figure 1 shows an overview of the the HIVE facility, the core elements of which are described in more detail in the following sections.

### 2.2. Location and infrastructure

HIVE is located within a building adjacent to JET on the Culham Science Center site in Oxfordshire, with existing power and services infrastructure, in close proximity to extensive specialist workshop facilities. This has not only provided significant capital cost savings during the procurement and commissioning phase of the facility, but will continue to ensure affordable and timely access to technical support for users in the periods leading up to and during operations.

Power is provided directly from the existing 415 V three-phase supply, with two dedicated feeds installed to supply the high-power requirements of heating and cooling systems and to support the remaining subsystems including the control cubicle and vacuum system. Steel support frames have been manufactured to support the vacuum vessel and heating workhead, and to provide a location for maintenance work to be carried out on the vessel lid assembly, including installation of the sample, coil, and instrumentation.

### 2.3. Vacuum vessel and sample mounting

The heart of HIVE is a small, bespoke 500 mm diameter by 500 mm high vacuum vessel shown in figure 2. Designed and tested to a leak rate less than  $10^{-9}$  mbar  $l s^{-1}$  it is also rated to a positive test pressure of 2 bar absolute, due to the need to retain integrity in the case of sample failure and coolant leak.

A 0.5 bar burst disk with an outlet to the building exterior provides passive protection limiting the possible overpressure in the event of such a failure. Pumping is provided by a  $240 l s^{-1}$  turbomolecular pump with the aim of providing sufficiently high vacuum to duplicate differential pressures and to minimise oxidation of components at elevated temperatures. Without baking the vessel, HIVE currently operates at  $2 \times 10^{-7}$  mbar.

Three 100 mm diameter and one 200 mm diameter equatorially-located ports provide a range of viewing angles through optical and IR transparent windows, while vacuum pumping and monitoring are located on a further two ports.

Figure 3 shows how the test piece and associated service connections are all mounted on the removable vacuum vessel lid, allowing maintenance and assembly to be carried out on a conveniently located maintenance frame located adjacent to the vacuum vessel itself.

<sup>†</sup><http://amazeproject.eu>



(a) Maintenance frame and control PC



(b) (from left to right) water supply, induction heating, vacuum vessel, and control cubicle

Figure 1: Overview of the HIVE facility



Figure 2: The HIVE vacuum vessel

#### 2.4. Heating

Heating is provided by a 45 kW, 50 kHz to 150 kHz induction heating system supplied by Ambrell Induction Heating Ltd.<sup>‡</sup>. As currently configured, this system provides up to approximately 8 kW of heating power at 80 kHz to the test sample via direct coupling, using a pancake coil arrangement as shown in figure 4.

Coupling efficiency of this kind of coil arrangement is theoretically 25% – 30% [8], and factory acceptance testing has confirmed performance at this level achieving to up to 12 kW delivered, equating to 30 MW m<sup>-2</sup> for an uncooled 20 mm square tungsten piece, but power

and pulse length is limited by the current cabling and feedthrough arrangements.

Coils for this system have been designed and procured for a range of sample sizes between 20 mm and 50 mm square, leading to incident heat fluxes between 5 MW m<sup>-2</sup> for the largest samples and 20 MW m<sup>-2</sup> for the smallest, allowing for modest transmission losses.

Operation at high frequency ensures that induced current density in the sample surface penetrates less than 1 mm into the surface, simulating a surface heat load similar to divertor and first wall conditions. If acceptable uniformity of heat flux at the armour-structure interface of a particular concept cannot be achieved by careful coil shaping and placement, increasing the tungsten thick-

<sup>‡</sup><https://www.ambrell.com>

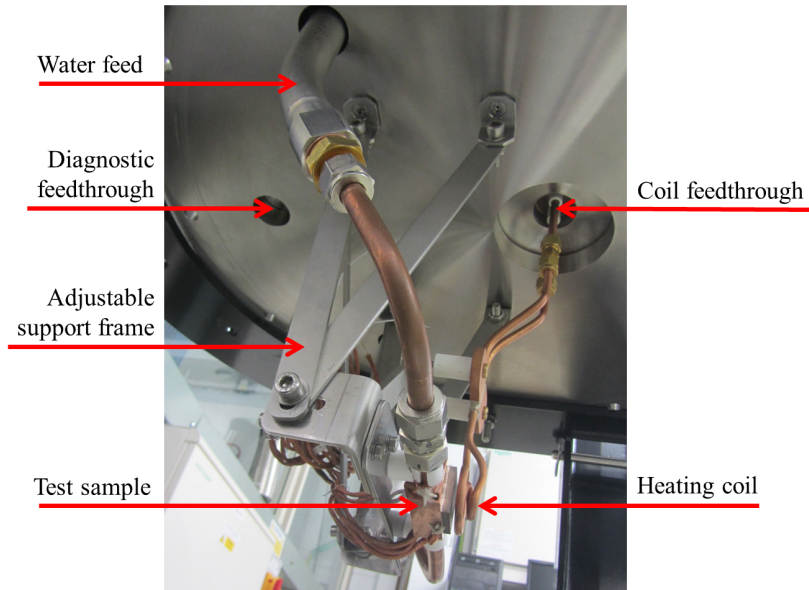

Figure 3: View of vacuum vessel lid from below showing coil and sample mounting arrangement

ness slightly will provide a more uniform heat distribution at this interface due to the tungsten's high conductivity, though consideration will need to be made of any resulting impact on component stresses. In addition, this will prevent the direct measurement of peak tungsten temperatures and surface temperature distributions. Alternatively, indirect heating can be employed, as has been used elsewhere [9], though this will significantly reduce the heat flux available.

### 2.5. Cooling

Water is supplied at up to 80 l/min between ambient pressure and temperature and 200 °C at 20 bar by a closed-loop Temperature Control Unit (TCU) from ICS Cool Energy Ltd<sup>§</sup> coupled with an external 20 kW chiller. Flow is controlled manually using a combination of in-line and bypass valves. DN40 stainless steel pipework provides low pressure drop between the TCU and flexible quick-release connections to the interface with the test sample. Pneumatically actuated shut-off valves minimise water loss and steam generation in the event of sample failure and pressure relief in the TCU provides additional protection against overpressure. Water temperature, pressure, and flow rate are monitored as described in section 2.6 to provide calorimetry and flow characterisation. The site-supplied water used in the system is chemically monitored and replaced regularly as required.

### 2.6. Instrumentation and control

Instrumentation and control are managed through a local cubicle containing a National Instruments<sup>¶</sup> RIO with

a range of modules to handle the digital and analogue inputs and control signals needed. This, in turn, is controlled via a custom LabView<sup>TM</sup> GUI on a local PC. Installed capacity is larger than current requirements giving scope for further expansion as upgrades occur.

While safety aspects of the facility are designed to be exclusively passive, plant protection logic is included on the inbuilt FPGA giving low latency, deterministic protection. The cubicle has full control of the heating, cooling, and vacuum systems, as well as the ability to control shut-off valves in the water line and a gate valve between the vacuum vessel and turbo pump.

Water flowrate and inlet and outlet pressure and temperature measurements from the TCU are supplemented by high-accuracy transducers placed in-line close to the sample. Sample temperatures are monitored by a combination of IR thermography and K-type thermocouples mounted externally and percussion welded into drilled pockets using well established JET practice. Heating power and frequency are recorded from the RF generator itself. Vacuum monitoring employs a combination pirani and inverted magnetron wide range gauge for pressure measurement and a residual gas analyser for leak testing and detection of outgassed material has recently been installed.

## 3. Sample design and manufacture

As outlined in section 1, the motivation for creating HIVE was primarily driven by the desire to test AM high heat flux components for the AMAZE project. However, in order to allow safe commissioning, characterisation of the performance of HIVE, calibration of transducers, and direct comparisons between AM and conventional

<sup>§</sup><https://www.icscoolenergy.com>

<sup>¶</sup><http://www.ni.com>

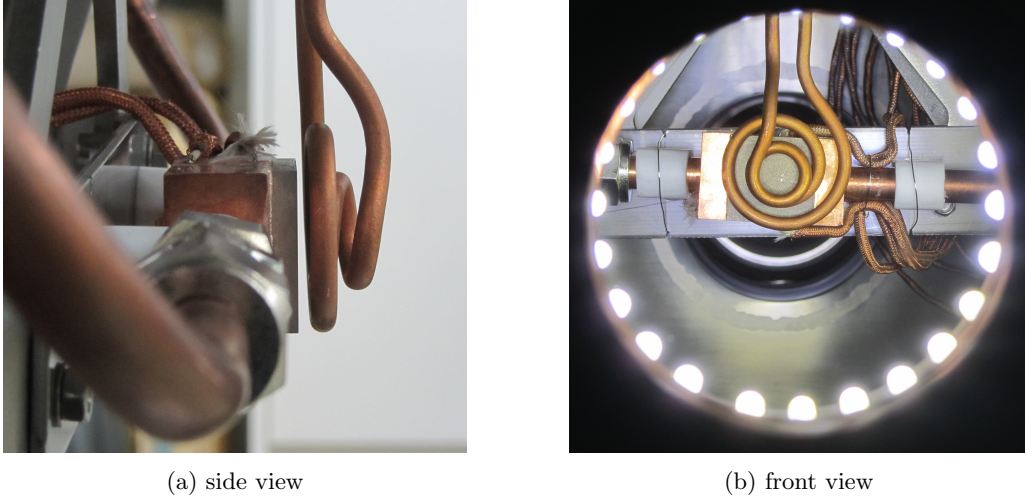

Figure 4: Coil and sample arrangement side and front views

technology, a stepwise approach was taken to test component design, beginning with a well understood combination of materials, cooling geometry, and manufacturing techniques before aiming to progress to a fully AM refractory component with complex cooling geometry. Unfortunately, due to limitations of the additive processes used and project time constraints, only the first steps along this progression have been completed to date. Further details of the design and manufacture of the additive components for AMAZE are included in [3] and [10].

First, a simple, conventionally manufactured “commissioning” sample was tested to the rear and sides of which a number of thermocouples were percussion welded. This was subsequently followed by a similar component with embedded rather than surface mounted thermocouples and finally a component in which the copper block was manufactured using electron beam melting on an ARCAM<sup>†</sup> system. These parts, the geometry of which is shown in figure 5, consisted of a 30 mm x 20 mm x 50 mm copper block brazed to 10 mm internal diameter copper feed pipes and 30 mm x 30 mm x 5 mm tungsten armour.

The vacuum brazing technique developed for this component and tested on both AM and conventional material allowed the joining of both pipes and armour to the central copper block in a single brazing cycle.

Prior to installation in HIVE, these components were helium leak tested to  $10^{-9}$  mbar $\cdot$ l $\cdot$ s $^{-1}$  and hydraulically pressure tested to 40 bar at room temperature. The calculation of test pressure (Equation 1) is drawn from the ITER structural design criteria for in-vessel components [11],

$$P_t = 1.25P_d \frac{S_m(T_t)}{S_m(T_d)} \quad (1)$$

where  $P_t$  and  $P_d$  are test pressure and design pressure respectively and  $S_m(T_t)$  and  $S_m(T_p)$  are the allowable

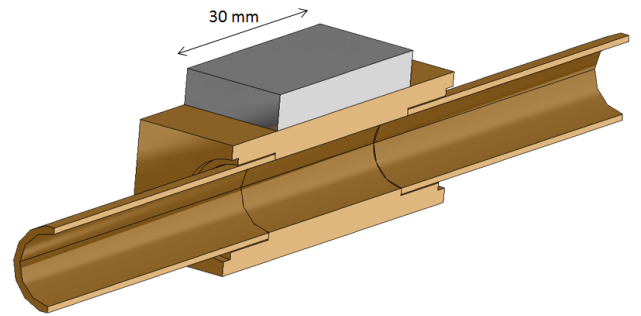

Figure 5: Geometry used for HIVE commissioning and AMAZE testing

stresses at test and design temperatures. This allows verification of component integrity at elevated temperature with testing at room temperature.

It is important to note that, in contrast to the final AMAZE concepts, the geometry chosen for comparison is not optimised for high performance and is limited by the low operational window of the pure copper structure, the simple pipe cooling geometry, and the high thermal mismatch stress at the copper-tungsten interface.

#### 4. Testing method

An operational window was defined for test components based on finite element analysis and heat transfer correlations in accordance with established methods for ITER components [12]. In this case, conservative limits were applied using margins to critical heat flux and plastic strain in the copper component. These limits were then converted to operational limits defined by coolant parameters and measured temperatures in both structure and coolant.

Samples were subjected to heat fluxes up to  $3 \text{ MW m}^{-2}$  with coolant at  $20^\circ\text{C}$  and  $50^\circ\text{C}$  and the resulting temper-

<sup>†</sup><https://www.arcam.com>

ature distributions were compared to one another and to empirical calculations and the aforementioned finite element models. Figure 6 shows indicative thermal and visual imagery of one such component under test in HIVE.



(a) Visible

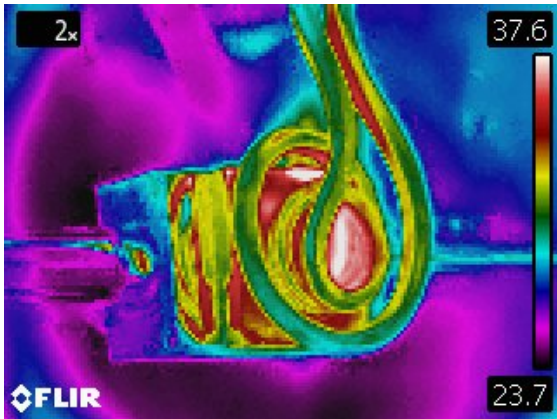

(b) IR

Figure 6: Visible and IR images of AMAZE AM component being tested in HIVE under low heat flux

Data was recorded from a total of six K-type thermocouples: four embedded in pockets in the copper and two mounted on the rear surface. Figure 7 shows the location of the thermocouple used for comparison of maximum sample temperature.

Figure 8 shows a representative signal plot during a typical HIVE pulse, including thermocouple readings and supplied power\*\*.

## 5. Results

Figure 9 shows the maximum temperature in the copper structure at the point described above with varying

\*\*Thermocouples here are given a three letter designation describing location within the sample: (t)op, (m)iddle, (b)ottom; (i)nlet, (m)iddle, (o)utlet; and (f)ront or (b)ack. Power is as reported at the generator, before transmission losses which, in this case, were as much as 90%.

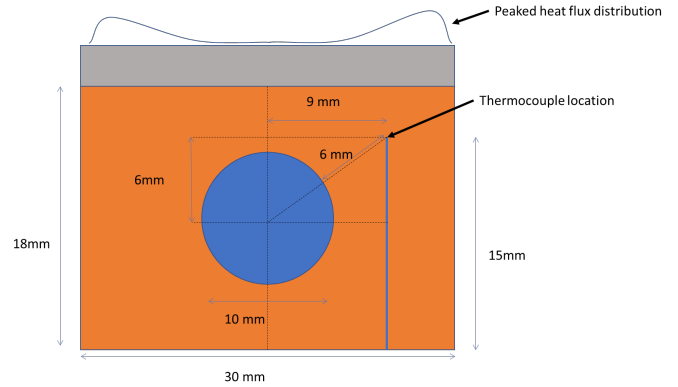

Figure 7: Thermocouple location and illustration of heat flux peaking (midplane cross section)

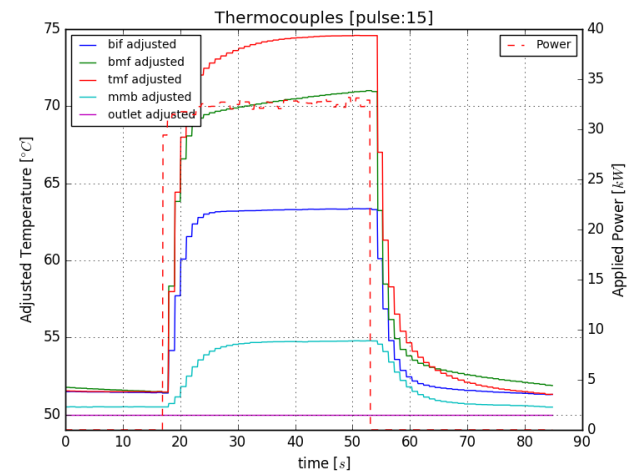

Figure 8: HIVE pulse graphs

power, given the same coolant conditions for each sample (in this case 50 °C water with a flow rate of 40l/min). 1D analytical calculations varying copper thermal conductivity and heat transfer coefficient were used to plot structural temperature vs input power and were compared with the experimental data to determine the driving mechanisms for performance differences between the AM and conventional components. An additional correction factor was used to take into account the non-uniformity of the applied heating.

The increased peak structural temperature of up to 15 °C shows that the AM sample does not perform as well as the conventional. The modelling suggests that the primary cause of this degradation is likely to be significant decrease in the thermal conductivity of the copper by approximately 60%. This reduction in thermal conductivity has yet to be compared with material property testing but although near ideal properties have previously been reported when sufficiently pure raw material is used[13], in this case significant phosphorous impurities were found to be present in the powder used, and this is likely to be a significant contributing factor. Applying



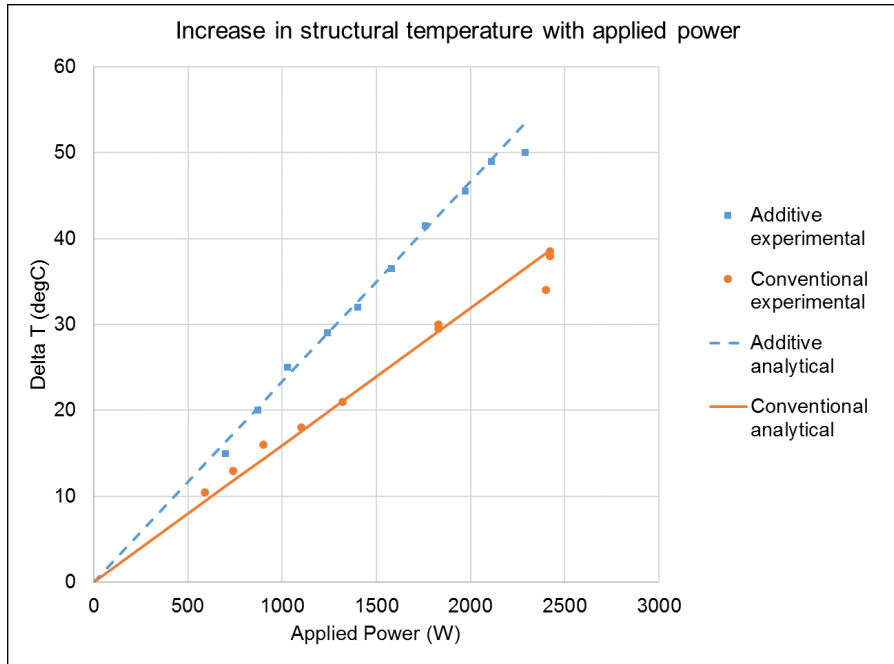

Figure 9: Maximum temperature increase in AM and conventional high heat flux samples with delivered power, compared to 1D analytical estimates

a 20% increase in the heat transfer coefficient between additive and conventional samples to the analytical calculation results in a further improvement in the correlation between modelling and experiment. This corresponds reasonably well to analytical estimates based on surface roughnesses of similar magnitude to the size of powder used, but will need to be verified by further testing. The difference in temperature readings between top and bottom thermocouples shown in figure 8 is the result of misalignment in the heating coil for this particular sample and improved coil design and placement have been shown to improve this significantly in subsequent tests. Uncertainties in calculating the applied heating distribution are the subject of an ongoing investigation and effects such as variation in braze joint quality are not included in the modelling, so will need to be resolved before the conclusions presented above can be considered more than preliminary.

## 6. Future work

### 6.1. Castellated tiles

Divertor tile armour is typically castellated to reduce thermal stress and to lengthen paths for induced currents during disruptions. A test programme is therefore underway to investigate the impact of such castellations on induction heating efficiency and homogeneity of heat flux with the existing coil design in HIVE. Figure 10 shows images of this testing.

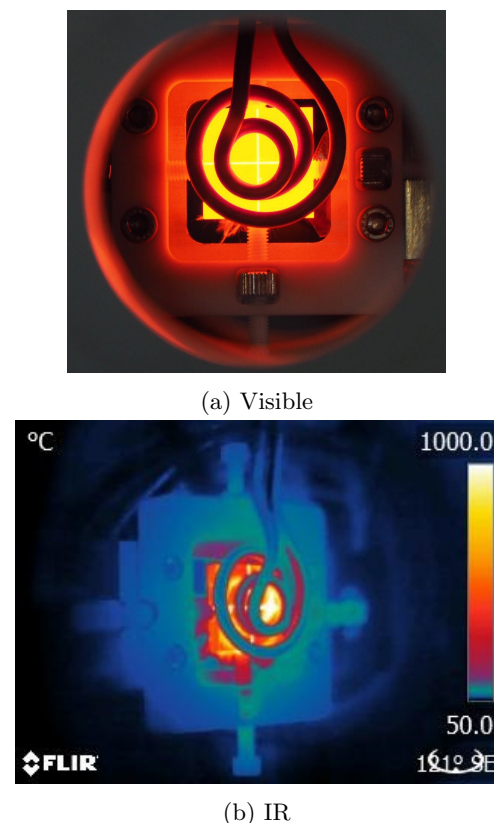

Figure 10: Visible and IR images of an uncooled castellated tungsten tile being tested at 1000 °C

## 6.2. Ongoing proposals

While water cooled tests were the primary goal of HIVE, uncooled tests during commissioning highlighted the usefulness of in-vacuum thermal cycling and plans are in place to investigate a number of tungsten coating technologies including vacuum plasma spraying, cold spray, and electrodeposition. The modular nature of the cooling system has also prompted proposals for CFD validation experiments and tests using alternative coolants, including nanofluids.

## 6.3. Upgrades and inclusion in new facilities

Future work will be supported by more detailed virtual engineering modelling and enhanced diagnostics, including high resolution IR thermography, digital image correlation measurements of strain, and spectroscopy of any outgassing from samples. A wider programme of upgrades, including integration into a newly announced Fusion Technology Facility (FTF) at UKAEA Culham, itself part of the more significant National Fusion Technology Platform (NaFTeP), includes the potential for duplicating the core concept of HIVE as a small component validation platform to allow parallel and extended duration testing under a range of conditions.

## 7. Conclusions

HIVE, a new small high heat flux facility has been designed and built at the Culham Centre for Fusion Energy. This facility provides a strategic resource, lying between in silico design and analysis and full scale particle beam or plasma-surface interaction testing. In particular, HIVE has demonstrated low operational and capital cost, high flexibility, and rapid sample turnover. HIVE has been used to test the first fully additively manufactured divertor target element prototype as part of the AMAZE project. These tests have provided direct comparison between additive and conventional components, using a simple, well-understood cooling geometry.

Performance degradation in the additive sample has been attributed to 60% lower thermal conductivity in the EBM copper compared to the conventional material, though evidence from empirical calculations points towards up to 20% increased convective heat transfer due to the rough internal surfaces. Further research is required, however, to verify these conclusions.

Future upgrades to HIVE, in part facilitated by its key role in the newly announced UK Fusion Technology Facility, are planned to extend its capability and a number of experimental campaigns are planned to demonstrate HIVE's potential contribution to a range of fusion and related applications.

## Acknowledgements

This work has been carried out within the framework of the EUROfusion Consortium and has received funding from the Euratom research and training programme 2014-2018 under grant agreement No 633053. This project has also received funding from the European Union's Seventh Framework Programme for research, technical development, and demonstration under grant agreement no 313781. The views and opinions expressed herein do not necessarily reflect those of the European Commission. This work has also been part-funded by the RCUK Energy Programme [grant number EP/P012450/1]. To obtain further information on the data and models underlying this paper please contact [publicationsmanager@ccfe.ac.uk](mailto:publicationsmanager@ccfe.ac.uk).

## References

- [1] F. Romanelli, Fusion Electricity: A roadmap to the realisation of fusion energy, Tech. rep., EDFDA (2012). doi: ISBN978-3-00-040720-8.
- [2] J. H. You, G. Mazzone, E. Visca, C. Bachmann, E. Autissier, T. Barrett, V. Cocilovo, F. Crescenzi, P. K. Domalapally, D. Dongiovanni, S. Entler, G. Federici, P. Frosi, M. Fursdon, H. Greuner, D. Hancock, D. Marzullo, S. McIntosh, A. V. Müller, M. T. Porfiri, G. Ramogida, J. Reiser, M. Richou, M. Rieth, A. Rydzy, R. Villari, V. Widak, Conceptual design studies for the European DEMO divertor: Rationale and first results, Fusion Eng. Des. 109-111 (PartB) (2016) 1598-1603. doi:10.1016/j.fusengdes.2015.11.012.
- [3] D. Hancock, D. Homfray, M. Porton, I. Todd, B. Wynne, Exploring Complex High Heat Flux Geometries for Fusion Applications Enabled by Additive Manufacturing, Fusion Eng. Des. in press.
- [4] H. Greuner, H. Bolt, B. Böswirth, T. Franke, P. McNeely, S. Obermayer, N. Rust, R. Süß, Design, performance and construction of a 2MW ion beam test facility for plasma facing components, Fusion Eng. Des. 75-79 (2005) 345-350. doi:10.1016/j.fusengdes.2005.06.021.
- [5] P. Gavila, B. Riccardi, S. Constans, J. L. Jouvelot, I. B. Vastra, M. Missirlian, M. Richou, High heat flux testing of mock-ups for a full tungsten ITER divertor, Fusion Eng. Des. 86 (9-11) (2011) 1652-1655. doi:10.1016/j.fusengdes.2011.02.012.
- [6] V. Kuznetsov, A. Gorbenko, V. Davydov, A. Kokoulin, A. Komarov, I. Mazul, B. Mudyugin, I. Ovchinnikov, N. Stepanov, R. Rulev, A. Volodin, Status of the IDTF high-heat-flux test facility, Fusion Eng. Des. 89 (7-8) (2014) 955-959. doi:10.1016/j.fusengdes.2014.04.064.
- [7] G. Pintsuk, M. Bednarek, P. Gavila, S. Gerzoskovitz, J. Linke, P. Lorenzetto, B. Riccardi, F. Escourbiac, Characterization of ITER tungsten qualification mock-ups exposed to high cyclic thermal loads, Fusion Eng. Des. doi:10.1016/j.fusengdes.2015.01.037.
- [8] S. L. Semiatin, Elements of Induction Heating: Design, Control, and Applications, ASM International, 1988.
- [9] S. A. Musa, B. Zhao, S. I. Abdel-Khalik, M. Yoda, Reversed Heat Flux Study of Impinging-Jet Water Cooling for Helium-Cooled Finger-Type Divertors, Fusion Sci. Technol. (2017) 1-6doi:10.1080/15361055.2017.1333829.
- [10] D. Hancock, M. Curtis-Rouse, A. Field, D. Homfray, H. Lewtas, M. Porton, E. Surrey, I. Todd, S. Williams, B. Wynne, Additive Manufacturing of High Temperature Materials for Fusion: A Review of Recent Work, Strategies, and Future Outlook, (Article Prep).
- [11] Structural Design Criteria for In-Vessel Components (SDC-IC), ITER Doc. G 74 MA 8 01-05-28 W0.2.

- [12] T. Barrett, S. McIntosh, M. Fursdon, D. Hancock, W. Timmis, M. Coleman, M. Rieth, J. Reiser, Enhancing the DEMO divertor target by interlayer engineering, *Fusion Eng. Des.* 98-99 (2015) 1216–1220. doi:10.1016/j.fusengdes.2015.03.031.
- [13] S. J. Raab, R. Guschlbauer, M. A. Lodes, C. K??rner, Thermal and Electrical Conductivity of 99.9% Pure Copper Processed via Selective Electron Beam Melting, *Adv. Eng. Mater.* doi:10.1002/adem.201600078.