



EUROfusion

WPBB-CPR(18) 19623

P. A. Di Maio et al.

Parametric thermal analysis for the optimization of Double Walled Tubes lay-out in the Water Cooled Lithium Lead inboard blanket of DEMO fusion reactor

Preprint of Paper to be submitted for publication in Proceeding of 36th Italian Thermofluid-dynamics Union Heat Transfer Conference



This work has been carried out within the framework of the EUROfusion Consortium and has received funding from the Euratom research and training programme 2014-2018 under grant agreement No 633053. The views and opinions expressed herein do not necessarily reflect those of the European Commission.

This document is intended for publication in the open literature. It is made available on the clear understanding that it may not be further circulated and extracts or references may not be published prior to publication of the original when applicable, or without the consent of the Publications Officer, EUROfusion Programme Management Unit, Culham Science Centre, Abingdon, Oxon, OX14 3DB, UK or e-mail Publications.Officer@euro-fusion.org

Enquiries about Copyright and reproduction should be addressed to the Publications Officer, EUROfusion Programme Management Unit, Culham Science Centre, Abingdon, Oxon, OX14 3DB, UK or e-mail Publications.Officer@euro-fusion.org

The contents of this preprint and all other EUROfusion Preprints, Reports and Conference Papers are available to view online free at <http://www.euro-fusionscipub.org>. This site has full search facilities and e-mail alert options. In the JET specific papers the diagrams contained within the PDFs on this site are hyperlinked

Parametric thermal analysis for the optimization of Double Walled Tubes layout in the Water Cooled Lithium Lead inboard blanket of DEMO fusion reactor

Pietro ARENA¹, Alessandro DEL NEVO², Pietro Alessandro DI MAIO¹,
Ruggero FORTE¹, Giulio NEVONE¹

¹ Università di Palermo, Dipartimento di Energia, Ingegneria dell'Informazione e Modelli Matematici, Viale delle Scienze, Edificio 6, I-90128 Palermo, ITALY.

² ENEA C.R. Brasimone, I-40032 Camugnano (BO), ITALY.

Corresponding author's e-mail: pietroalessandro.dimaio@unipa.it

Abstract. Within the roadmap that will lead to the nuclear fusion exploitation for electric energy generation, the construction of a DEMONstration (DEMO) reactor is, probably, the most important milestone to be reached since it will demonstrate the technological feasibility and economic competitiveness of an industrial-scale nuclear fusion reactor. In order to reach this goal, several European universities and research centres have joined their efforts in the EUROfusion action, funded by HORIZON 2020 UE programme. Within the framework of EUROfusion research activities, ENEA and University of Palermo are involved in the design of the Water-Cooled Lithium Lead Breeding Blanket (WCLL BB), that is one of the two BB concepts under consideration to be adopted in the DEMO reactor. It is mainly characterized by a liquid lithium-lead eutectic alloy acting as breeder (lithium) and neutron multiplier (lead), as well as by subcooled pressurized water as coolant. Two separate circuits, both characterized by a pressure of 15.5 MPa and inlet/outlet temperatures of 295 °C/328 °C, are deputed to cool down the First Wall (FW) and the Breeder Zone (BZ). The former consists in a system of radial-toroidal-radial C-shaped squared channels where countercurrent water flow occurs while the latter relies in the use of bundles of poloidal-radial Double Walled Tubes (DWTs) housed within the breeder.

A parametric thermal study has been carried out in order to assess the best DWTs' layout assuring that the structural material maximum temperature does not overcome the allowable limit of 550 °C and that the overall coolant thermal rise fulfils the design target value of 33 °C. The study has been performed following a theoretical-numerical approach based on the Finite Element Method (FEM) and adopting the quoted Abaqus FEM code. Main assumptions and models together with results obtained are herewith reported and critically discussed.

1. Introduction

In the next future, nuclear fusion power reactors might represent a very interesting alternative to the conventional power plants using fossil fuels for electric energy generation. Within the roadmap leading to the realization of net electric power from nuclear fusion reactions on an industrial scale [1], the DEMONstration (DEMO) fusion reactor will have the role of proving the technical feasibility of such a power plant assessing, at the same time, its economic competitiveness on the worldwide energy market. Aiming at the achievement of this goal, the major European research centres and universities have joined their effort under the EUROfusion project, funded by HORIZON 2020 UE framework programme.

Within the framework of the Work Package Breeding Blanket (WPBB) of the EUROfusion action promoting the Breeding Blanket (BB) research activities [2,3], ENEA and University of Palermo are deeply involved in the design of the Water-Cooled Lithium Lead (WCLL) BB concept, that is currently one of the two options under consideration for the DEMO reactor. In particular, it foresees the adoption of the liquid lithium-lead eutectic alloy Pb-15.7Li as breeder and neutron multiplier and the use of pressurized subcooled water as coolant, flowing at the average pressure of 15.5 MPa with an inlet temperature of 295°C and an outlet one of 328°C.

According to the DEMO Baseline 2015, the WCLL BB is foreseen to be toroidally segmented into 18 sector of 20°, each one housing 3 BB outboard segments and 2 BB inboard segments [4] directly facing the plasma and mechanically coupled by an upper poloidal plug. As to each segment, both Multi Module System (MMS) and Single Module System (SMS) have been investigated by the WCLL BB design team as potential options for its configuration, the former one being based on the adoption of poloidal stacks of modules welded to a Back Supporting Structure (BSS) while the latter one being characterized by a poloidal-oriented “banana-shaped” structural box, housing the breeder under quasi-stagnant conditions. In particular, numerical simulations performed during 2015-2017 [5,6,7] have pointed out the low efficiency of the MMS configuration, especially in terms of breeder drainage, helium extraction, hot spot temperatures and stress intensity mainly under electro-magnetic loads. The research efforts have, hence, been focused onto the inboard and outboard SMS segments, that are currently under investigation to finalize the design of their structural box and cooling system.

In particular, as a consequence of both its position and shielding function, the WCLL BB is heavily exposed to both surface and volumetric heat loads due to the high heat flux arising from plasma and to the intense heat power deposited inside its volume as a consequence of the interactions with neutrons and photons, respectively. The WCLL BB cooling system plays, hence, a pivotal role in the reactor operation and its design results particularly demanding since it has to effectively extract the overall heat power deposited into the module while keeping the structure temperature below its prescribed limit, to avoid the occurrence of thermal and structural crisis, without incurring in an unduly pumping power. Furthermore, it has to maintain the breeder temperature beyond the solidification point to avoid local formation of breeder solid grains that might endanger its normal circulation, to be considered as propaedeutic to tritium extraction. Therefore, a significant effort has been made since 2014 by the WCLL BB design team in order to assess an effective design for the cooling system of this blanket concept, considering several cooling system solutions and assessing their thermal-hydraulic performances for both the inboard and outboard SMS segments.

Within this framework finds its place the research activity reported in the present paper, that has been focussed on the optimization of the thermal-hydraulic performances of the cooling circuit conceived to remove nuclear-deposited heat power from the breeder of a typical WCLL BB SMS inboard segment. The optimization has been performed following a theoretical-numerical approach based on the Finite Element Method (FEM) and performing parametric FEM analyses by means of the Abaqus v6.14 commercial code. Main assumptions and models together with the results obtained are herewith reported and critically discussed.

2. WCLL breeding blanket inboard segment

As reported in [7,8], the WCLL BB segment design is currently oriented towards the SMS concept, which seems to show better performances than the MMS one, especially in terms of mechanical performances. According to this concept, the WCLL BB inboard segment is mainly composed by a EUROFER steel [9] actively-cooled banana-shaped structure named Segment Box (SB) that delimits the so-called Breeder Zone (BZ) where neutron multiplication and tritium breeding take place (Fig. 1).

In particular, the SB is articulated in a First Wall (FW), two Side Walls (SWs) and a Back Plate (BP) and it is reinforced against over-pressurization accidents and electro-magnetic loads by a system of poloidal-radial (vertical) and toroidal-radial (horizontal) Stiffening Plates. Conversely, the BZ houses the breeder flowing, under quasi-stagnant conditions, according to a U-shaped path along radial-poloidal-radial directions.

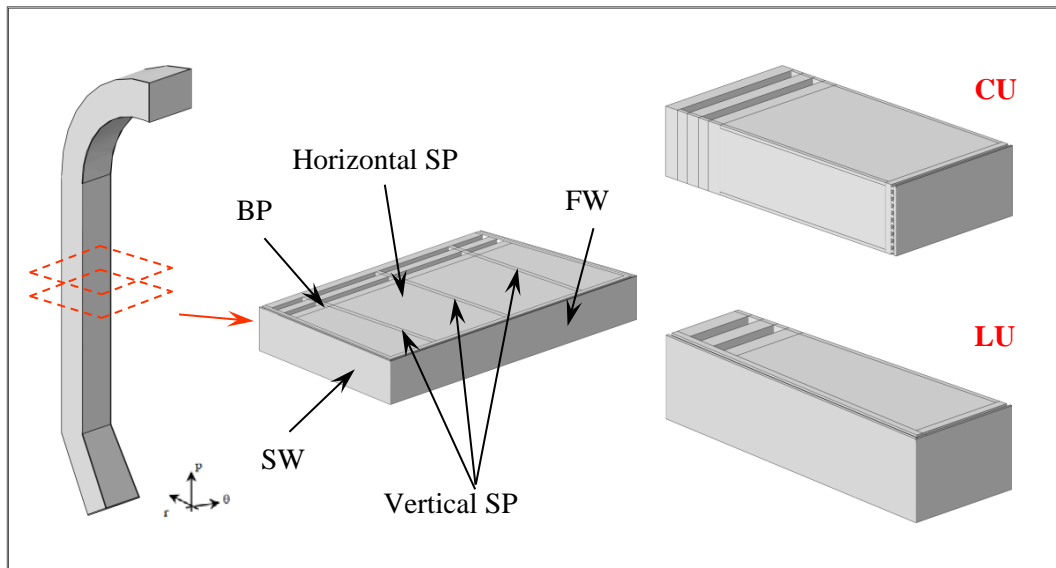

Fig.1. WCLL BB inboard segment.

The whole segment may be considered as composed of a poloidal sequence of elementary toroidal-radial cells, each one composed of two Central Unit (CU) and two Lateral Unit (LU) (Fig. 1).

The WCLL BB inboard segment cooling system is mainly articulated in two independent cooling circuits devoted to separately cool the SB and the BZ. The former relies in a set of radial-toroidal-radial C-shaped squared cooling channels (7x7 mm), poloidally arranged with a pitch of 13.5 mm, where water coolant countercurrent flow occurs with a thermal rise of 33°C from the inlet temperature of 295°C to the outlet one of 328°C. The latter is based on the use of bundles of poloidal-radial Double Walled Tubes (DWTs) housed within the breeder, where water coolant flows experiencing the same thermal rise of the SB cooling circuit. In particular, DWTs [10], made in EUROFER and characterized by an internal diameter of 8 mm and a thickness of 5.5 mm, have been widely adopted for the design of the WCLL BB concepts with the aim of reducing the likelihood of possible liquid metal-water interaction.

3. Double Walled Tubes layout optimization

The main assignment of the BZ cooling circuit is the removal of the heat power deposited within the breeder as a consequence of the interactions of its nuclei with neutrons and photons. It has to be achieved under steady state conditions while keeping the maximum temperature of SB below the limit of 550°C, prescribed by safety codes for the EUROFER, and the breeder minimum temperature beyond the limit of Pb-15.7Li eutectic alloy solidification point ($\approx 300^\circ\text{C}$).

The design of BZ cooling circuit results particularly demanding and a research campaign has been, hence, launched in close cooperation between ENEA and University of Palermo with the specific aim to assess an optimized DWTs layout, suitable to effectively reach the target goal and meet the safety requirements while minimizing the number of tubes to be adopted.

To this purpose, the WCLL BB inboard segment design equipped with a “beer box” SP grid configuration has been considered, that relies on the use of both horizontal and vertical SPs extending for the whole radial length of the module, from FW to BP, and delimiting several toroidal-radial cells articulated in central and lateral units (CUs and LUs), each provided with its own bundle of DWTs. Accordingly, the assessment of the optimized DTWs layout has been carried out for either a CU and a LU by running a specific set of parametric thermal FEM analyses. Finally, these optimized DWTs layouts have been implemented into an equatorial elementary toroidal-radial cell of the WCLL BB inboard segment and its overall thermal-hydraulic behaviour has been numerically assessed by running a specific thermal FEM analysis.

3.1. Central Unit

As far as the CU is concerned, three different DWTs layouts have been investigated (Fig. 2) composed of 3, 4 and 5 DWTs, respectively (Fig. 2). In particular, all of the configurations considered are characterized by poloidal-radial DTWs equally spaced along the toroidal direction, so to pursue a more uniform cooling of the SPs. The DWTs have been placed at a distance of 1 cm from both the horizontal and vertical SPs and 1 cm far from the FW internal surface.

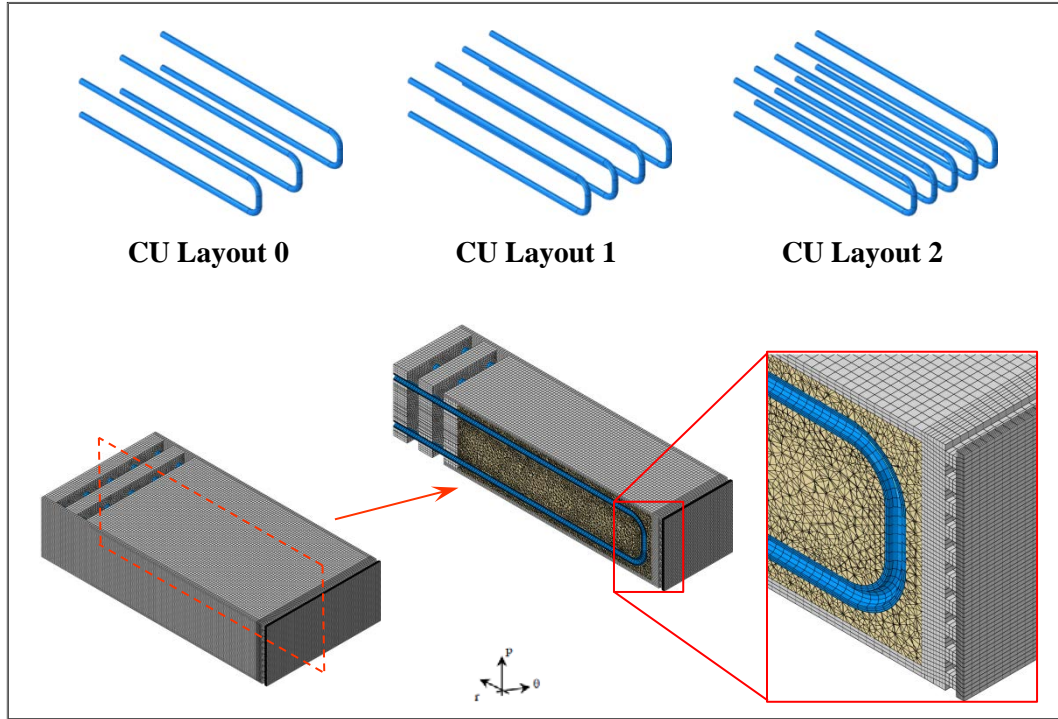

Fig.2. CU layouts and FEM models.

A detailed FEM model including the structure and the breeder has been set up for each layout under investigation, typically composed of $\sim 0.45 \cdot 10^6$ nodes connected in $\sim 1.1 \cdot 10^6$ linear elements (Fig. 2). As to the thermal loads, a radial-dependent volumetric density of nuclear-deposited heat power, drawn from [10], has been implemented into the model while a heat flux of 0.5 MW/m^2 has been imposed on the model plasma facing surface. Moreover, convective boundary conditions have been implemented at both the FW cooling channels and the DWTs interfaces with coolant. To this purpose, heat transfer coefficients (h) have been computed by means of the Dittus&Bölter correlation [11], taking into account a preliminary estimate of coolant mass flow rate distribution per channel or tube based on that assessed for the WCLL BB outboard segment and reported in [12]. The bulk temperature has been uniformly imposed to $311.5 \text{ }^\circ\text{C}$, as the average value between the coolant inlet ($295 \text{ }^\circ\text{C}$) and outlet ($328 \text{ }^\circ\text{C}$) reference temperatures. A summary of the boundary conditions applied to the models is reported in Table 1, where the mass flow rate G is relevant to a single tube or channel.

Table 1. CU cooling circuit parameters.

| | G [kg/s] | h [$\text{W}/(\text{m}^2 \text{ }^\circ\text{C})$] |
|--------------------|------------|--|
| CU Layout 0 | 0.0643 | 17441 |
| CU Layout 1 | 0.0483 | 13855 |
| CU Layout 2 | 0.0386 | 11590 |
| FW | 0.0776 | 21239 |

Since the breeder is expected to flow at few mm/s within the BZ, due the simultaneous action of natural convection and magneto-hydrodynamic forces, it has been considered as stagnant and a pure diffusive heat transfer has been, hence, assumed within the BZ domain, neglecting convective transport phenomena as widely accepted and already done in previous analyses [10,13,14,15]. A thermal contact model has been implemented at all of the breeder-wetted surfaces of the model, characterized by a conservative thermal conductance of 100 kW/(m² °C).

A steady state thermal analysis has been performed for each configuration under investigation and its thermal response has been numerically assessed. The maximum temperatures predicted in the SB as well as in the BZ are reported in Table 2.

Table 2. Maximum temperatures predicted for CU layouts.

| | T _{MAX, SB} [°C] | T _{MAX, BZ} [°C] |
|--------------------|---------------------------|---------------------------|
| CU Layout 0 | 711.0 | 760.2 |
| CU Layout 1 | 577.2 | 654.6 |
| CU Layout 2 | 533.4 | 598.3 |

As may be deduced from the analysis of Table 2, the results obtained show that the layout equipped with 5 DWTs (CU Layout 2) is the only one, among those investigated, suitable to cool the SB structure while complying with the EUROFER maximum temperature requirement. In fact, according to the thermal field distribution reported in Figure 3, the CU Layout 2 allows to obtain a maximum temperature of 533.4 °C, reached in correspondence of the vertical SPs.

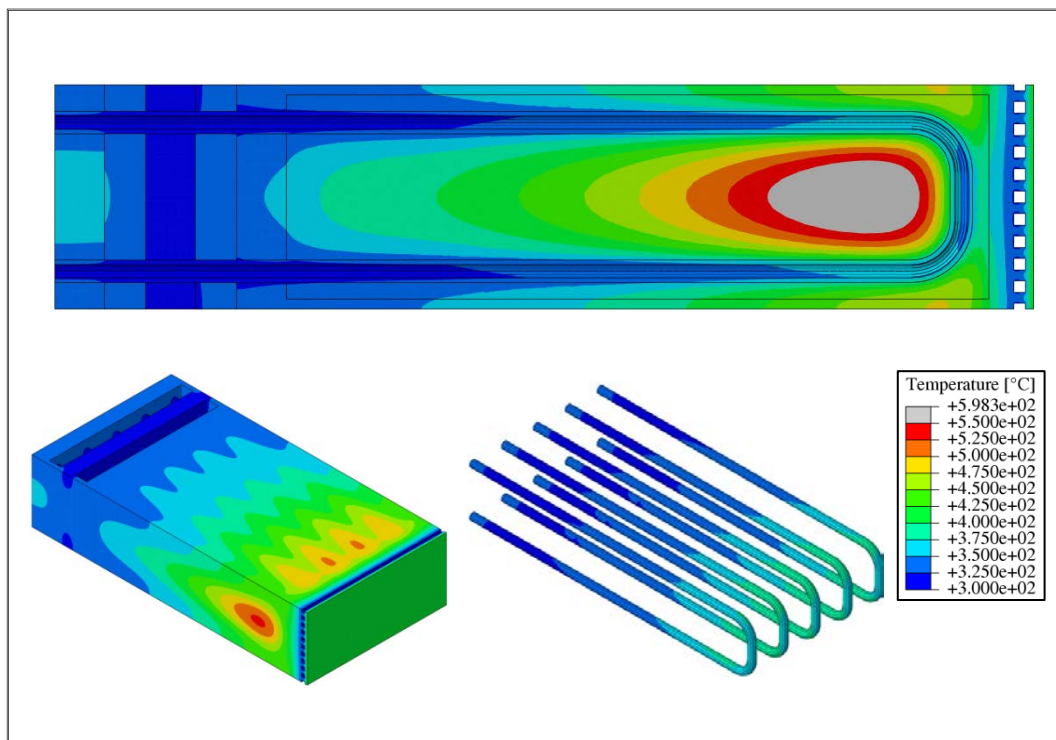

Fig.3. CU Layout 2 thermal field.

Furthermore, it has to be underlined that a minimum breeder temperature of 321.0 °C has been calculated for all the configurations analysed. It overcomes the limit value of 300 °C and, hence, allows the breeder solidification process to be reasonably excluded under normal operation.

3.2. Lateral Unit

The same procedure followed for the CU has been adopted for the thermal analysis of the LU. In particular, only two DWTs layouts (LU Layout 0 and LU Layout 1) have been taken into account in this case (Fig. 4), due to the reduced toroidal space available to accommodate them.

Both the layouts maintain the same characteristic distances from the other components already mentioned in the CU case, but they are characterized by a different orientation of the most external tube, which is rotated of 3.33° around the poloidal axis in order to follow the SW direction, remaining at the same toroidal distance of 1 cm from it.

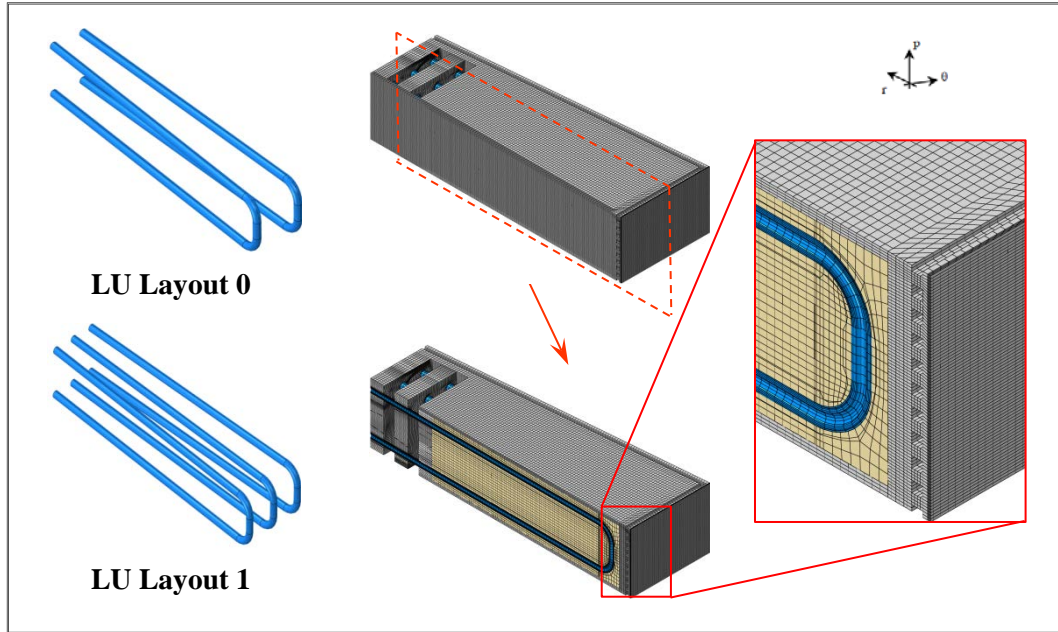

Fig.4. LU layouts and FEM model.

The same volumetric and surface heat loads adopted for the CU analysis have been imposed to the models, but different convective boundary conditions, according to the data reported in [12] and reported in Table 3, have been implemented.

Table 3. LU cooling circuit parameters.

| | G [kg/s] | h [W/(m ² °C)] |
|--------------------|----------|---------------------------|
| LU Layout 0 | 0.0597 | 16418 |
| LU Layout 1 | 0.0398 | 11869 |
| FW | 0.0776 | 21239 |

A steady state thermal analysis has been performed for each configuration under investigation and its thermal response has been numerically assessed. The maximum temperatures predicted in the SB as well as in the BZ are reported in Table 4.

Table 4. Maximum temperatures predicted for LU layouts.

| | T _{MAX, SB} [°C] | T _{MAX, BZ} [°C] |
|--------------------|---------------------------|---------------------------|
| LU Layout 0 | 551.8 | 609.9 |
| LU Layout 1 | 530.3 | 577.9 |

They clearly show that a minimum of 3 DWTs (LU Layout 1) is needed in order to allow the maximum SB temperature to line up at 530.3 °C, well below the required limit of 550 °C. Moreover, the thermal field of the LU Layout 1 is reported in Figure 5, showing that the maximum SB temperature of 530.3 °C is reached in correspondence of the vertical SP.

Finally, it has to be stressed that a minimum breeder temperature of 314.9 °C has been calculated for all the configurations analysed. It overcomes the limit value of 300 °C and, hence, allows the breeder solidification process to be reasonably excluded under normal operation.

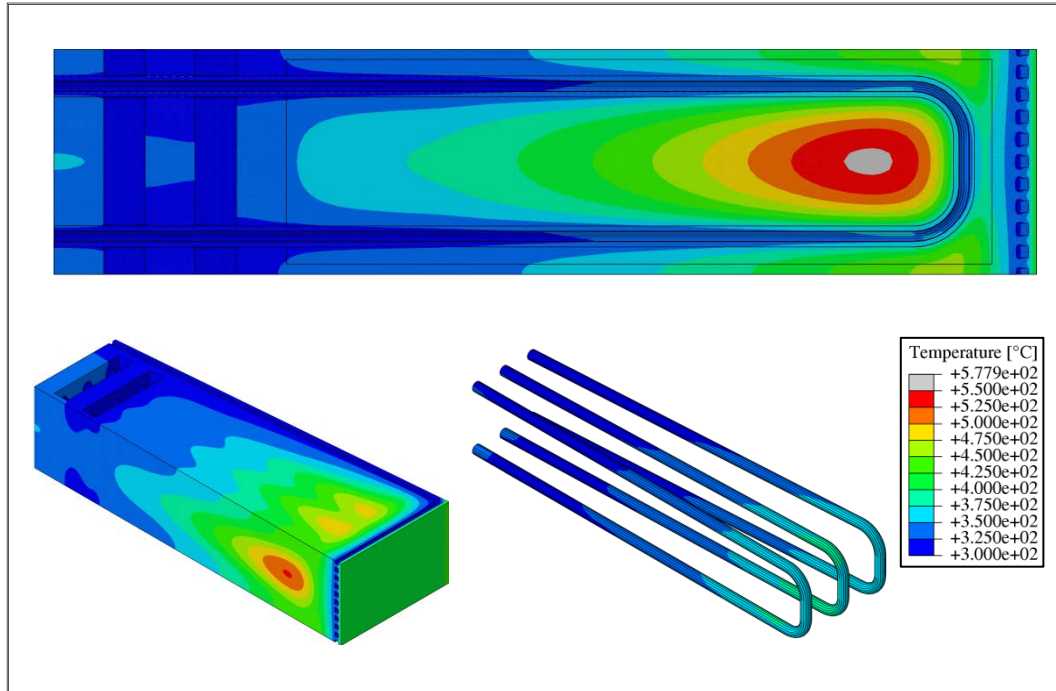

Fig.5. LU Layout 1 thermal field.

3.3. WCLL-BB inboard segment equatorial elementary cell

According to the planned activity, the optimized DWTs layouts assessed by means of the parametric analysis campaign for both CUs and LUs have been implemented into an equatorial elementary cell of the WCLL BB inboard segment to assess its overall thermal-hydraulic behaviour by running a specific thermal FEM analysis.

To this purpose a FEM model of the “optimized” WCLL-BB inboard segment equatorial elementary cell has been set up, endowed with $\sim 2.4 \cdot 10^6$ nodes connected in $\sim 2.5 \cdot 10^6$ linear elements. In order to obtain a more realistic temperature distribution, the elementary cell water domains housed within both the DWTs and the SB cooling channels have been additionally modelled. To this purpose, the same procedure already adopted in [14] has been followed in order to simulate the convective heat transfer between the structure and the coolant. In particular, a simplified “frozen” flow field approach has been adopted modelling the water domains by means of hexahedral forced convection/diffusion elements, which hold the heat transfer convective-diffusive transport equation. The coolant velocity field has been assumed to be known and, typically, the mass flow rate for unit area has been imposed to each material point, so that the velocity could be automatically code-calculated by means of the mass density. The heat flux entering the coolant domain at the steel walls interface has been prescribed by means of an appropriate thermal contact model, which couples the temperatures of the structure and the coolant by means of the following equation:

$$q''_{ij} = h(T_i^{\text{wall}} - T_j^{\text{coolant}}) \quad (1)$$

where q''_{ij} is the heat flux flowing through the coupled nodes i and j , belonging to the steel walls and the water coolant, respectively, and h is the heat transfer coefficient.

The BZ cooling circuit inlet and outlet have been supposed to be placed at the bottom and the top of the elementary cell, respectively. An inlet temperature of 295 °C has been assumed for the coolant and an iterative analysis procedure has been adopted to determine the updated mass flow rate distribution per channel/tube suitable to reach the reference coolant outlet temperature of 328 °C. In particular, observing that the DWTs optimized configurations share almost the same mass flow rate per tube (Tables 1 and 3) it has been possible to determine a unique mass flow rate value to be adopted for all the DWTs, ensuring the coolant outlet mixing temperature to be equal to 328 °C with a coolant maximum outlet temperature of 332.1 °C, well below the saturation temperature of 344.8 °C (@15.5 MPa).

The mass flow rate values implemented into the model have been reported in Table 5. The heat transfer coefficients have been again calculated at the average temperature of 311.5 °C by means of the Dittus&Bölter correlation.

Table 5. WCLL BB inboard segment equatorial elementary cell cooling circuits parameters.

| | G [kg/s] | h [W/(m ² °C)] |
|------------|----------|---------------------------|
| DWT | 0.0295 | 9347 |
| FW | 0.0679 | 19089 |

A steady state thermal analysis has been carried out and the thermal field distribution within the model has been obtained (Fig.s 6-8). As it may be observed, the results show a good agreement with those obtained by the parametric analyses of the Central and Lateral units. In particular, a maximum temperature of 531.4 °C has been predicted for the SB in correspondence of the central vertical SP, well below the limit value prescribed for the EUROFER (550°C). This value matches quite well the corresponding value of 533.4°C predicted by the parametric analyses for the CUs. Moreover, as to the BZ, minimum and maximum temperatures 304.6°C and 611.4 °C have been predicted, respectively, allowing to exclude any risk for the considered configuration to incur in breeder solidification issues.

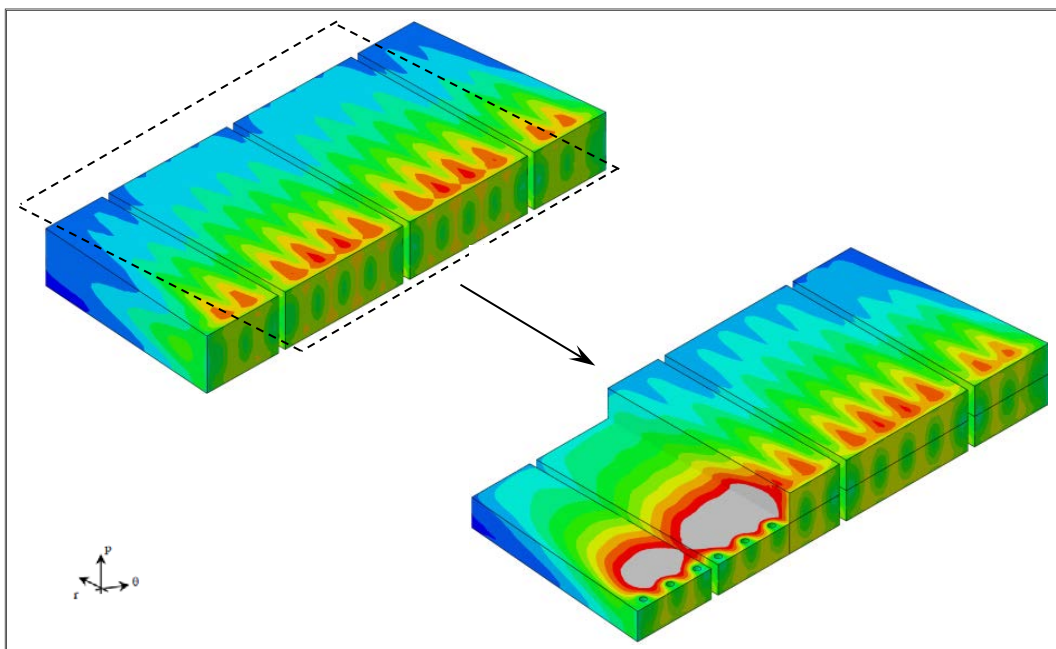

Fig.6. WCLL BB inboard segment equatorial elementary cell. BZ thermal field.

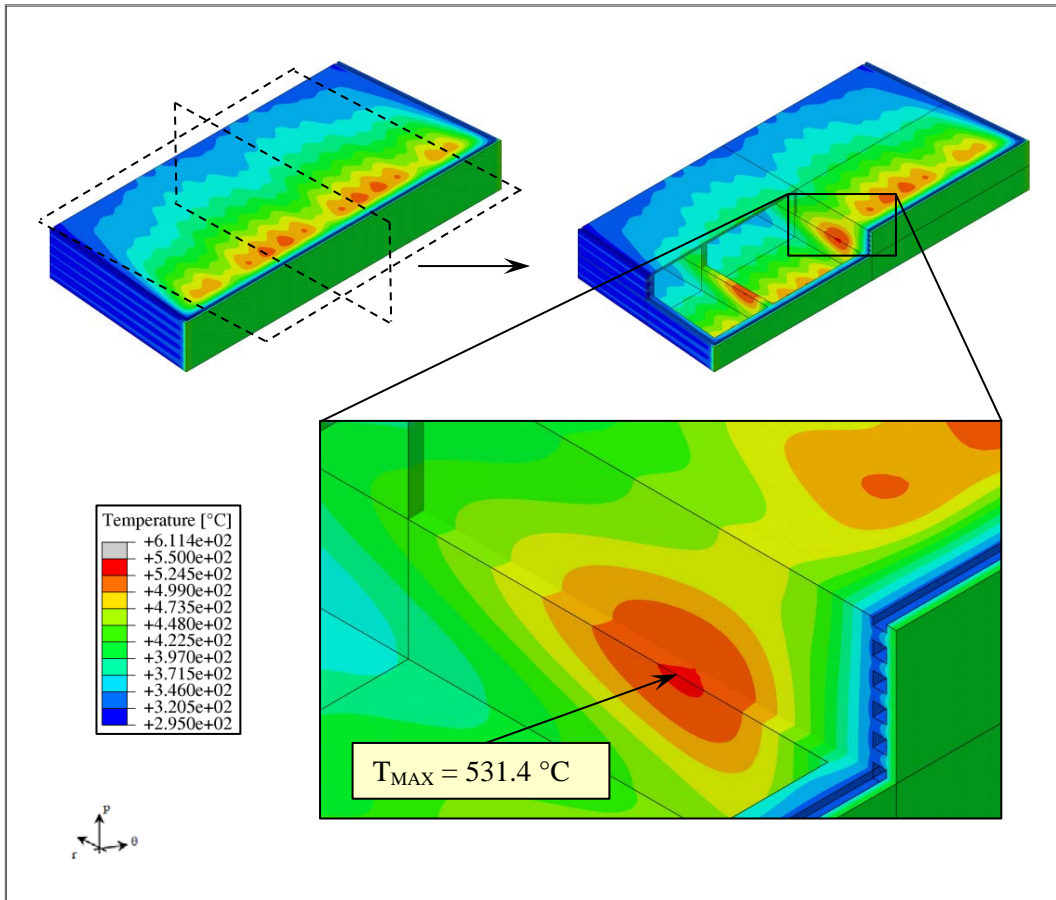

Fig.7. WCLL BB inboard segment equatorial elementary cell. SB thermal field.

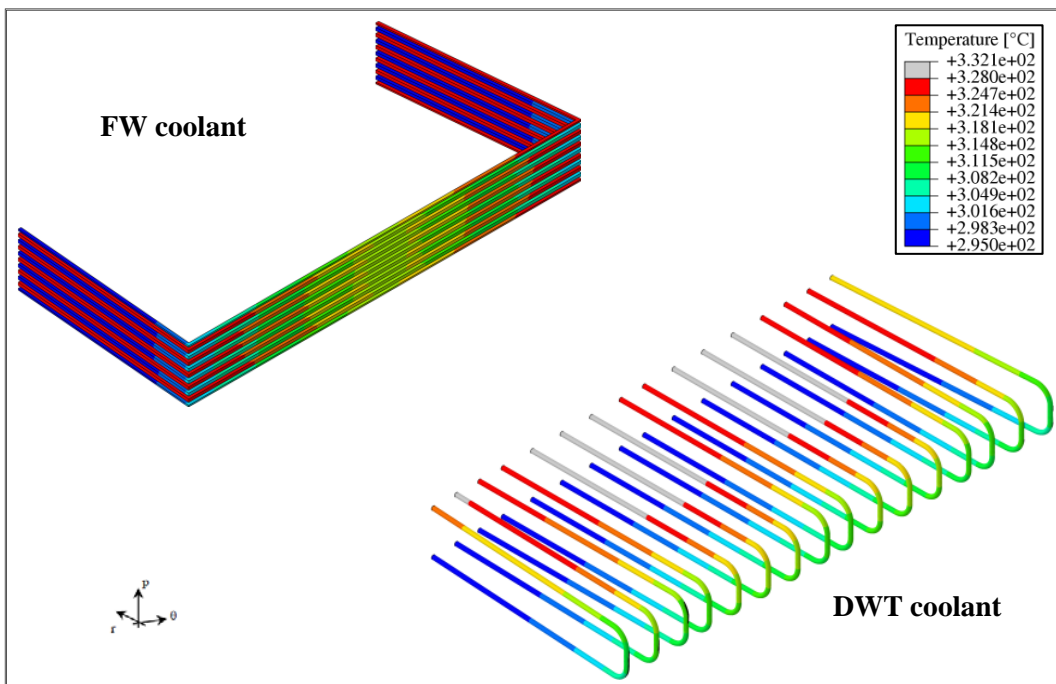

Fig.8. WCLL BB inboard segment equatorial elementary cell. Coolant thermal field.

4. Conclusions

Within the framework of the DEMO WCLL BB research activity, a parametric thermal study has been carried out by ENEA and University of Palermo, with the aim of determining an optimized configuration of the BZ cooling circuit of the WCLL BB SMS inboard segment, suitable to effectively remove nuclear-deposited heat power and meet the safety requirements in terms of maximum temperature of the structural material ($< 550^{\circ}\text{C}$) and minimum temperature of the breeder ($> 300^{\circ}\text{C}$), while minimizing the number of tubes to be adopted.

The thermal-hydraulic performances of several DWTs layouts of both the CUs and LUs of the WCLL BB inboard segment equatorial elementary cell have been numerically investigated by means of parametric thermal analyses finding out that the optimized lay-outs have to include 5 and 3 DWTs for each CUs and LUs, respectively.

These layouts have been finally implemented into an equatorial elementary cell of the WCLL BB inboard segment to assess its overall thermal-hydraulic behaviour. The elementary cell steady state thermal response has been numerically predicted, showing a maximum structure temperature of 531.4°C , computed in correspondence of the central vertical SP, and a minimum breeder temperature of 304.6°C . The former is well below the EUROFER limit value of 550°C , allowing to exclude any thermal crisis for the structural material, while the latter results slightly beyond the breeder limit value of 300°C , allowing to exclude any risk to incur in breeder solidification issues under normal operation.

Disclaimer

This work has been carried out within the framework of the EUROfusion Consortium and has received funding from the Euratom Research and Training Programme 2014–2018 under grant agreement no. 633053. The views and opinions expressed herein do not necessarily reflect those of the European Commission.

References

- [1] Romanelli F. et al. "Fusion Electricity-A roadmap to the realisation of fusion energy", 2012.
- [2] Federici G. et al. "Overview of the design approach and prioritization of R&D activities towards an EU DEMO", *Fusion Eng. Des.*, Vol. **109-111** (2016), pp. 1464-1474.
- [3] Boccaccini L.V. et al. "Objectives and status of EUROfusion DEMO blanket studies", *Fusion Eng. Des.*, Vol. **109-111** (2016), pp. 1199-1206.
- [4] Tassone A. et al. "Recent Progress in the WCLL Breeding Blanket Design for the DEMO Fusion Reactor", *IEEE Trans. on Plasma Science*, Vol. **46** Issue 5 (2018), pp. 1446-1457.
- [5] Del Nevo A. et al. "WCLL breeding blanket design and integration for DEMO 2015: status and perspectives", *Fusion Eng. Des.*, Vol. **124** (2017), pp. 682-686.
- [6] Martelli E. et al. "Thermo-hydraulic analysis of EU DEMO WCLL breeding blanket", *Fusion Eng. Des.*, Vol. **130** (2018), pp. 48-55.
- [7] Bongiovì G. et al. "Multi-Module vs. Single-Module concept: comparison of thermomechanical performances for the DEMO Water-Cooled Lithium Lead breeding blanket", *Fusion Eng. Des.*, <https://doi.org/10.1016/j.fusengdes.2018.05.037>.
- [8] Di Maio P. A. et al. "Numerical assessment of the thermomechanical behaviour of the DEMO Water-Cooled Lithium Lead inboard blanket equatorial module", *Fusion Eng. Des.*, <https://doi.org/10.1016/j.fusengdes.2018.04.098>.
- [9] Tavassoli A., Fusion Demo Interim Structural Design Criteria (DISDC)/Appendix A Material Design Limit Data/A3. S18E Eurofer Steel, EFDA TASKTW4-TTMS-005-D01, CEA Report DMN/DIR/NT/2004-02/A, December 2004.
- [10] Chiovaro P. et al. "Optimization of the breeder zone cooling tubes of the DEMO Water-Cooled Lithium Lead breeding blanket", *Fusion Eng. Des.*, Vol. **109-111** (2016), pp. 227-231.
- [11] Incropera F.P., Dewitt D.P. "Fundamentals of Heat and Mass Transfer", 2nd edition, John Wiley & Sons, 1985.

- [12] WCLL Design Report 2017, IDM Ref EFDA_D_2MYHNE v1.0.
- [13] Di Maio P. A. et al. "On the optimization of the first wall of the DEMO water-cooled lithium lead outboard breeding blanket equatorial module", *Fusion Eng. Des.*, Vol. **109-111** (2016), pp. 335-341.
- [14] Di Maio P. A. et al. "On the thermo-mechanical behaviour of DEMO water-cooled lithium lead equatorial outboard blanket module", *Fusion Eng. Des.*, Vol. **124** (2017), pp. 725-729.
- [15] Arena P. et al. "Thermal optimization of the Helium-Cooled Lithium Lead breeding zone layout design regarding TBR enhancement", *Fusion Eng. Des.*, Vol. **124** (2017), pp. 827-831.