

---

# 25 Years of JET

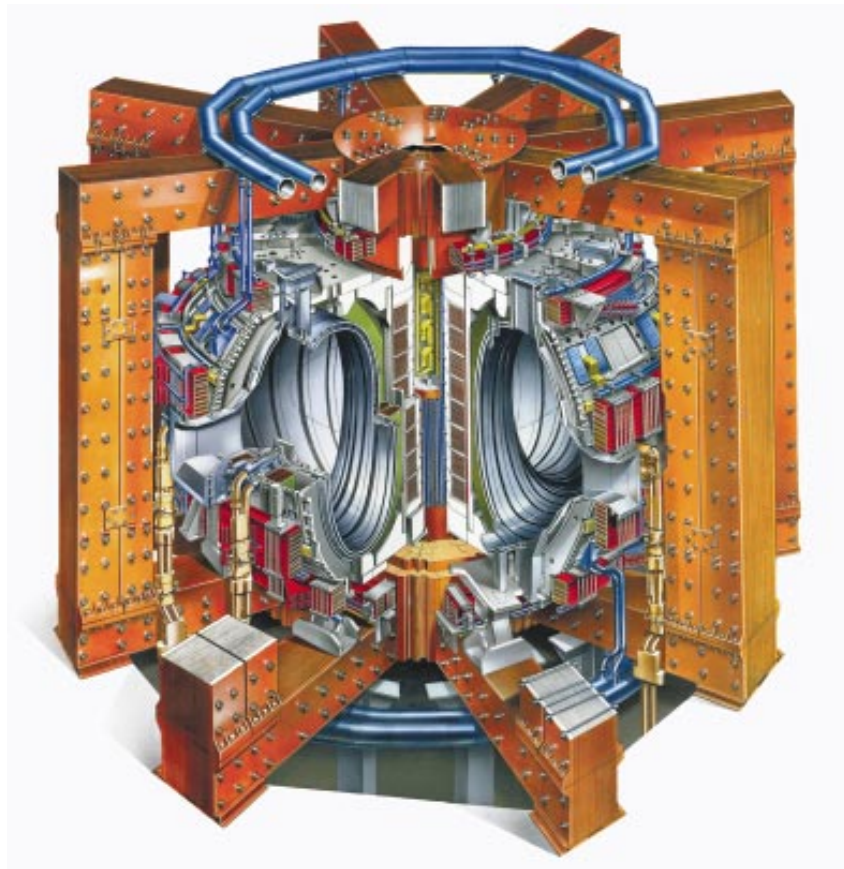

*Contributions to the  
Development of  
Fusion Energy*

"This document is intended for publication in the open literature. It is made available on the understanding that it may not be further circulated and extracts may not be published prior to publication of the original, without the consent of the Publications Officer, JET Joint Undertaking, Abingdon, Oxon, OX14 3EA, UK".

"Enquiries about Copyright and reproduction should be addressed to the Publications Officer, JET Joint Undertaking, Abingdon, Oxon, OX14 3EA".

# 25 Years of JET

*Contributions  
to the  
Development  
of Fusion  
Energy*

# Introduction

- Following the *1958 'Atoms for Peace' Conference in Geneva*, where the first results in controlled thermonuclear fusion were declassified, EURATOM decided to foster fusion research in the Community.
- European National Laboratories involved in fusion progressively became part of the *EURATOM collaborative programme* through 'Contracts of Association', and quickly focused on magnetic confinement fusion



JET was first known as "*la Proposition Pease*" (Director of the Culham Laboratory)

*A. Schlüter* (left) and *C. Braams* (right) seen here with *D. Palumbo* discussing the foundation of JET

- Following progress of the Tokamak concept, invented by Russian scientists in the early sixties, in 1972 EURATOM and the Associated Laboratories decided to set up the *Joint European Tokamak Working Group* to define the objectives, the outline design and the main parameters of a *large tokamak* to be designed, constructed and operated within the framework of the European collaboration

# Objectives of JET

- The essential objective was to **study a plasma in conditions as close as possible to a fusion reactor**, including operation in D-T, i.e. to study:
  - *Scaling of plasma behaviour* as parameters approach the reactor range
  - *Plasma-wall interaction* and control of the impurities with thermonuclear grade plasma
  - *Methods of plasma heating*, suitable to bring the plasma in the reactor regime
  - *Alpha particle production*, confinement and consequent plasma heating
- A '**Design Phase Agreement**' came into force in **October 1973**, when the Design Team was progressively assembling in Culham (UK) under the leadership of **P.H. Rebut** who supervised the construction of JET and the first phases of its experimental programme



## **P-H Rebut**

Head of the JET Design Team  
(1973 – 1978)

Director of the JET Joint Undertaking  
(1985 – 1992)

# Design Philosophy

- *Moderate toroidal magnetic field (3.4T)*, and *D-shaped coils* which reduce electro-mechanical stresses, making a coil casing unnecessary and thus allowing maximum access
- *Large number of external toroidal coils (32)*, to reduce magnetic field ripple
- *Large plasma volume ( $>100\text{m}^3$ )* and *current (design value 4.8MA D shaped, 3MA circular)*, *long pulse capability (20-60s)*, *D-shaped vacuum vessel and plasma*, for the full use of the magnetic field volume, and allowing an increased plasma current

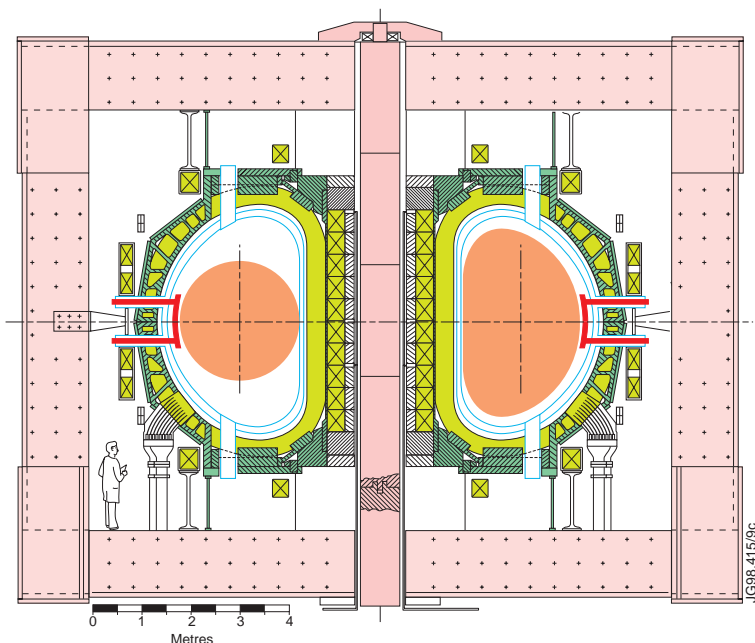

Parameter	Value
Major radius, R(m)	2.96
Minor radius, a(m)	1.25
Elongation, b/a	1.68
Magnetic field, $B_T$ (T)	3.45
Plasma current, $I_p$ (MA)	4.80
Operating time (3MA), t(s)	20
Vacuum vessel $V_p$ ( $\text{m}^3$ )	150

JG988.415/10c

- *Double wall vacuum vessel*, to allow first wall operation at high temperature (350°C) by interspace flow of hot air/helium, and to act as double containment for tritium
- *Tight aspect ratio (R/a)*, with centering force of the toroidal coils transferred to the inner support cylinder via the central solenoid
- *Central solenoid* subdivided into pancakes with independent electrical connections, to facilitate manufacturing and operational flexibility

# Design Philosophy

- **Modular construction** of the machine, in **8 octants**, each consisting of a section of the vacuum vessel, 4 toroidal coils and the associated mechanical structure
- From the start, the design of the machine took into account **Remote Handling** interventions following **D-T operation** campaigns. This requirement gave an impact to the design of every component
- **Reprocessing plant for the machine exhaust gases**, during **D-T operation**, to recycle tritium and so reduce the amount on site
- **Torus Hall biological shield** and radiation resistant components specified to permit high power DT operation
- Principal **diagnostics** designed with the operating elements outside the Torus Hall
- Over half of the **electric power** and most of the energy to be taken directly from the **400kV grid**
- Similar initiatives were taken by the **United States** with the **Tokamak Fusion Test Reactor (TFTR)**, by **Japan** with the **Japanese Tokamak-60 (JT-60)** and by the **Soviet Union** with the **Tokamak-15 (T-15)**

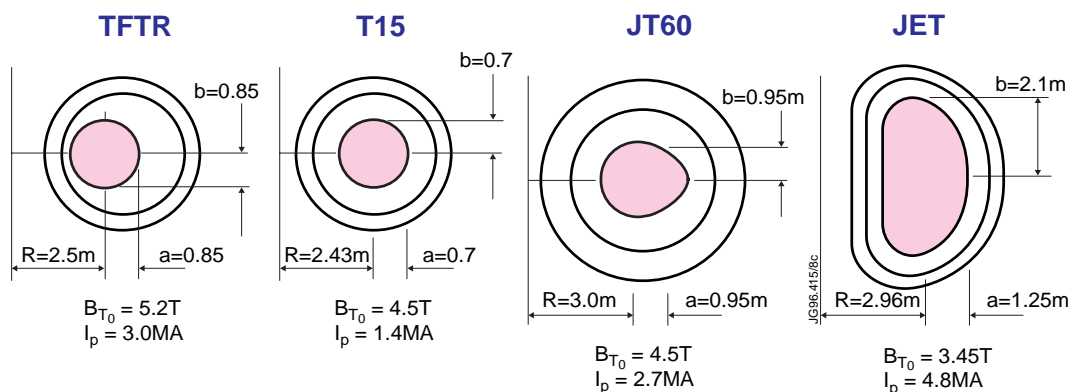

# JET Design and Siting

In the short period from September 1973 to May 1975 the JET Design Team delivered and got approval for the JET Design report (EUR-JET-R5). 1976 and 1977 were periods of real uncertainty for the Design Team as political agreement was sought on a site for JET. The Design Phase Agreement was extended several times, ultimately to 30<sup>th</sup> September 1977. **Eventually on 25<sup>th</sup> October 1977, the Research Ministers decided on a site at Culham in the UK**



**The Site Committee**  
1974/1975

Overall view of the **JET Tokamak** as described in the JET Design Report

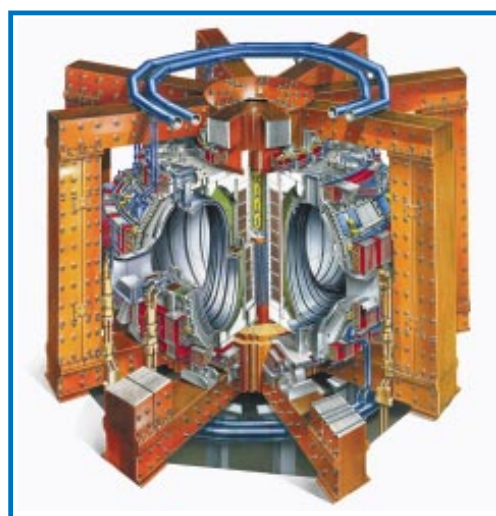

82.348c



Construction and initial operation of JET took place under the leadership of **H-O Wüster** the first director of the JET Joint Undertaking (1978 – 1985)



# Construction

The detailed arrangements for the JET Joint Undertaking were agreed by the Council of Ministers on 30<sup>th</sup> May 1978 and the **Joint Undertaking came into being on 1<sup>st</sup> June 1978**. Site work began in March 1979



79.817c4c

Dr Guido Brunner, the European Commissioner responsible for Research, inaugurates the start of civil work on the JET site, in May 1979



80.485c

Site construction would proceed around the clock: work for massive foundations of the Torus Hall, at night



83.772c

The JET machine being assembled in early 1983



82T.103b54

One of the toroidal coils being lifted to become part of a machine octant



82T.228b55

One octant, consisting of a section of the vacuum vessel, of 4 toroidal coils, and of the mechanical support structure, being transferred to the Torus Hall for final assembly

# Plasma Heating and Current Drive Systems

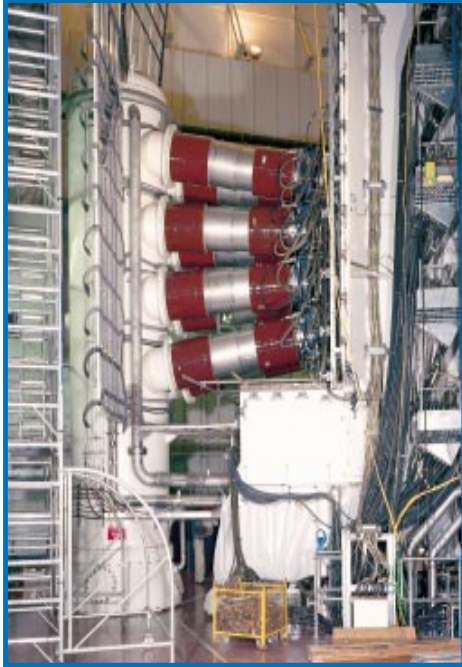

- There are **16 Neutral Beam Injection lines** arranged in two units of 8. Each line can operate at **80kV, 60A** or at **160kV, 30A**, with a total heating power of **20MW**

The two units or “boxes”, of 8 lines each, inject power through “Octant 4” and “Octant 8”

- **Four pairs of Ion Cyclotron Frequency (ICRF) antennae** are installed on the outer side of the vacuum vessel first wall, operating at **25-55MHz**, with a total heating power of **20MW**

- One **Lower Hybrid Frequency (LHCD) launcher**, operating at **3.7GHz**, can supply up to **10MW** to the plasma and can control plasma current profiles and can drive the plasma current



J96.164c6

# JET Diagnostics

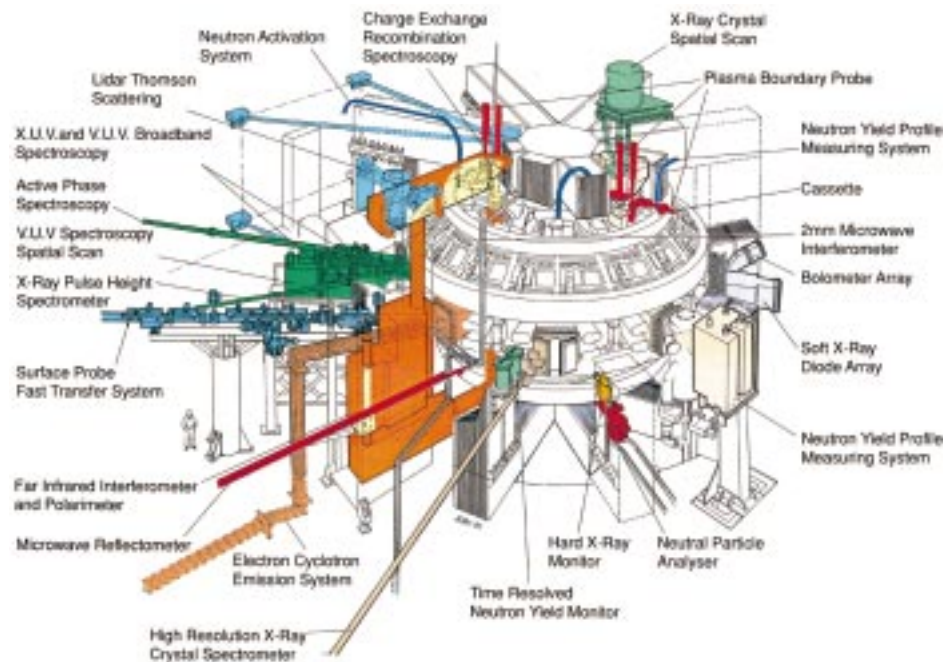

Overall view of the [JET Diagnostics](#)

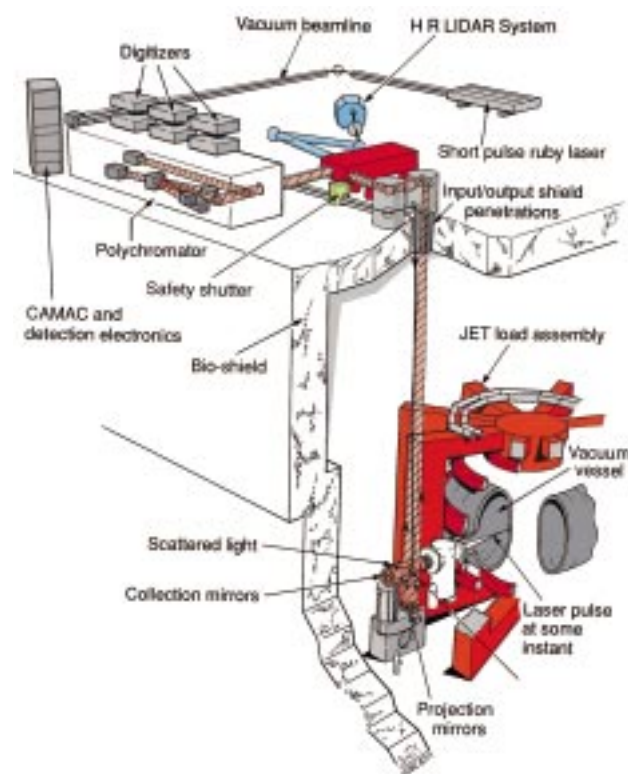

The [LIDAR Thomson scattering diagnostic](#) for the measurement of  $T_e$  and  $n_e$  profiles, has the operating elements outside the biological shield

# Early Results

- **First operation (1983-84)** with only ohmic heating clearly showed that large plasma volumes and currents generated **energy confinement times** in the reactor range ( $\sim 1s$ ) and **high ion temperatures** ( $\sim 3keV$ )
- As soon as NB and ICRF additional heating systems (1984-86) were used, the ion temperature increased to reactor values ( $\sim 12keV$ ), but the **decay of the energy confinement time with heating**, previously observed in **limiter configuration** smaller tokamaks, such as PLT (USA) and TFR (France), became clearly evident, in experiments conducted in a wide range of plasma currents (**1MA to 5MA**)
- **X-point configurations** were also established up to **3MA**, allowing the plasma to enter the H-mode regime, first developed in the ASDEX tokamak (Germany)

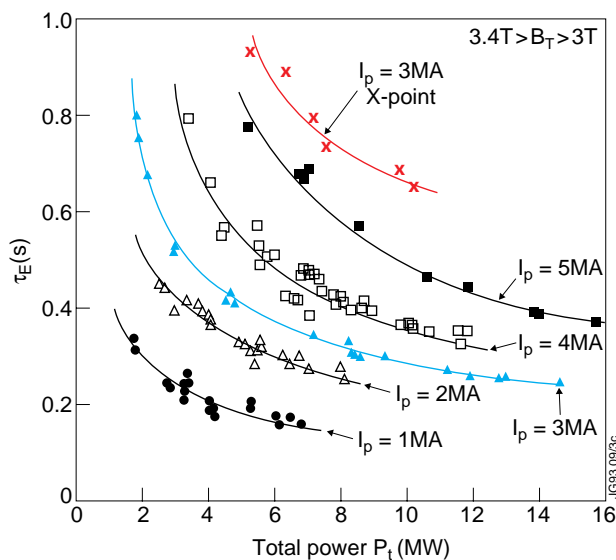

Behaviour of the energy confinement time  $\tau_E$  with total heating power  $P_t$  in limiter (L-mode) and in X-point (H-mode) configurations

- It was definitively shown that **X-point configurations** and **large plasma currents** allowed the production of long ( $\sim 1s$ ) reactor relevant energy confinement times in the presence of strong additional heating which in turn produced reactor relevant temperatures

# Wide impact of JET Results

- These JET results had a major impact on the world-wide tokamak programme
- In the light of JET results *reactor designs* such as *NET* in Europe were reviewed to substantially increase the plasma current up to **20MA** and the subsequent design of the *International Thermonuclear Experimental Reactor (ITER)* eventually settled on a plasma current of **21-24MA**



JG96.72/7c

ITER conceptual design (ITER-CDA)

# Major Machine Upgrading

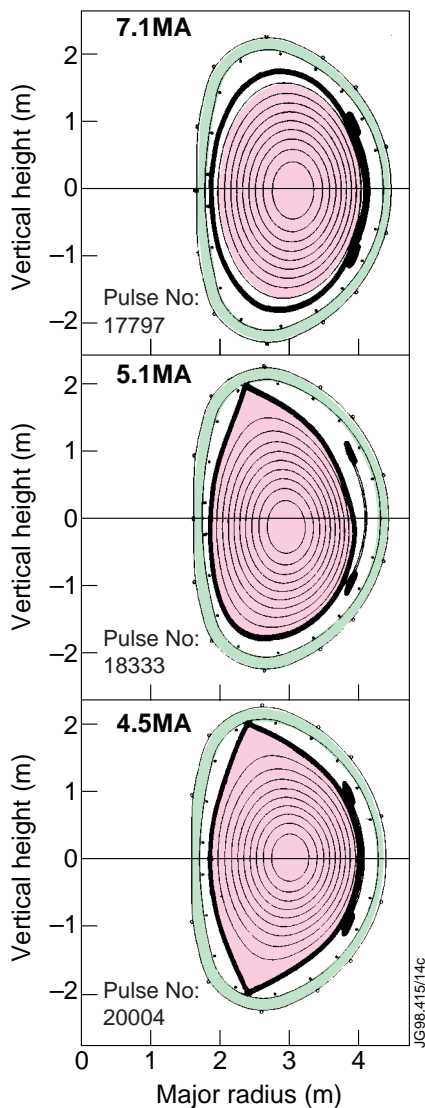

The *Electro-magnetic system of JET* was modified to allow larger plasma currents (7MA with limiter and 5MA with X-point), by increasing from 40 to 60kA the maximum current in six (out of ten) inner pancakes of the central solenoid, taking advantage of the pre-compression exercised by the toroidal coils. New power supplies to feed the six inner pancakes were needed

- In order to reduce the plasma impurity parameter  $Z_{\text{eff}}$  the first wall was progressively covered with *graphite tiles*, later also with *beryllium tiles* in critical positions and supplemented by *beryllium evaporation* onto the vessel walls between pulses



J91.483c

# Results after Upgrading

- Operation after machine modification and upgrading to *7MA with limiter and to 5MA with X-point (1986-88)* led to substantial improvement in global performance. *Ion temperature (20 keV), density ( $1.2 \times 10^{20}$ )* and *energy confinement time (1.2s)*, although in separate experiments, were now all in the reactor range

Experimental Programme	Peak Ion* densities $n_i$ ( $10^{20} \text{ m}^{-3}$ )	Peak Ion* temperature $T_i$ (keV)	Energy* confinement time $\tau_E$ (s)	$Z_{\text{eff}}$	Fusion product $n_i \tau_E T_i$ ( $10^{20} \text{ m}^{-3} \text{ s keV}$ )	Equivalent $Q_{\text{DT}}$
Ohmic Heating (1983–1984)	0.4	3.0	1.0	3–10	1.2	0.01
Additional Heating (1984–1986)	0.5	12.0	0.9	2–5	2.0	0.3
Machine Upgrading (1986–1991)	1.2	20.0	1.2	2–3	2.5	0.3
Passive Control of Impurities (1988–1991)	4.0	30.0	1.8	1–2	9	1.07

JG98.415/4c

- The *performance was further improved (1988-91)* with the introduction of *beryllium* as first wall material. Under these machine conditions, JET has reached a *fusion parameter* only 6 times short of ignition and a D-T equivalent gain parameter  $Q_{\text{DT}} \sim 1$  (*breakeven*)

# Improving Plasma Performance

Plasma Performance improved dramatically when the density of the plasma in the central region was increased using pellets of Deuterium ice. This was thought to be due to the modified current distribution in the plasma.

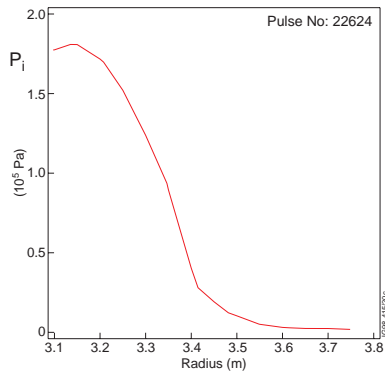

Pellet Enhanced Performance (1988-90) shows centrally peaked profiles being sustained with reversed magnetic shear

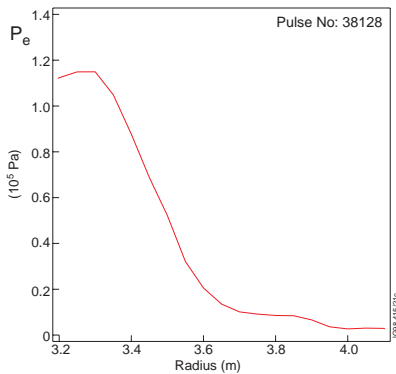

Similar results were later achieved (1996) at JET and elsewhere by deliberate modification of the current distribution

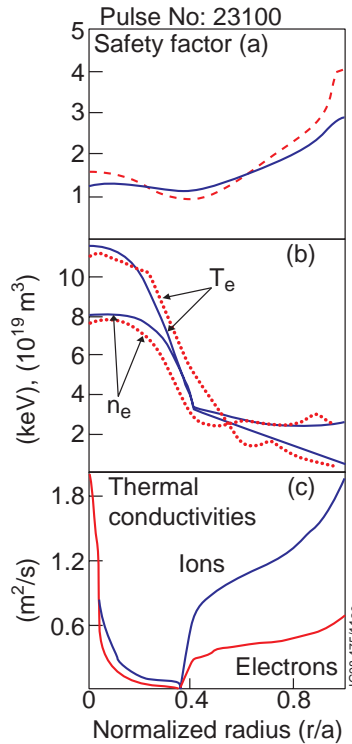

(a),(b) and (c) show results of a PEP pulse simulation using a transport Code (solid curves)

(a) q-profile (dashed curve calculated using equilibrium Code).

(b) electron temperature and density profiles (dotted curves are LIDAR measurements)

(c) ion and electron thermal conductivities, reducing to neoclassical levels

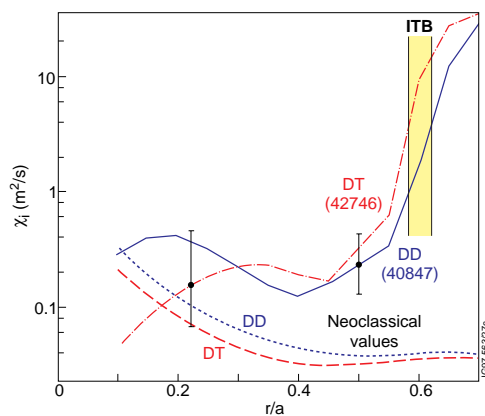

Ion thermal diffusivities versus normalised plasma radius for two optimised shear discharges in D-D and D-T and comparison with neo-classical values

Energy losses are strongly reduced inside the Internal Transport Barrier



# Preliminary Tritium Experiment (PTE)

At the end of 1991 JET conducted a ground breaking experiment: **a significant amount of controlled fusion energy was produced for the first time**

9<sup>TH</sup> NOVEMBER 1991

- 10% tritium, 90% deuterium
- 14.3MW of heating
- 1.7MW peak fusion power
- 2MJ fusion energy
- Tritium handling successfully demonstrated

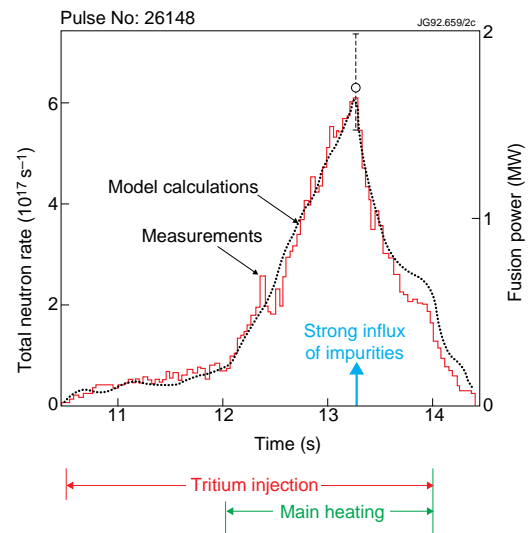

Pulse No: 26148, 9<sup>th</sup> Nov. 1991

This result had an unprecedented impact on the media leading to a broad public perception of the potential of fusion energy



JET staff in the Control Room sharing the excitement of PTE

Subsequently in 1994 the US experiment TFTR achieved fusion power in excess of 10 MW

# Why a Divertor

- *By the end of 1991*, JET results had largely fulfilled the original objectives. However the *high performance could only be maintained transiently*, limited by a combination of MHD instabilities and accumulation of impurities (“carbon bloom”)

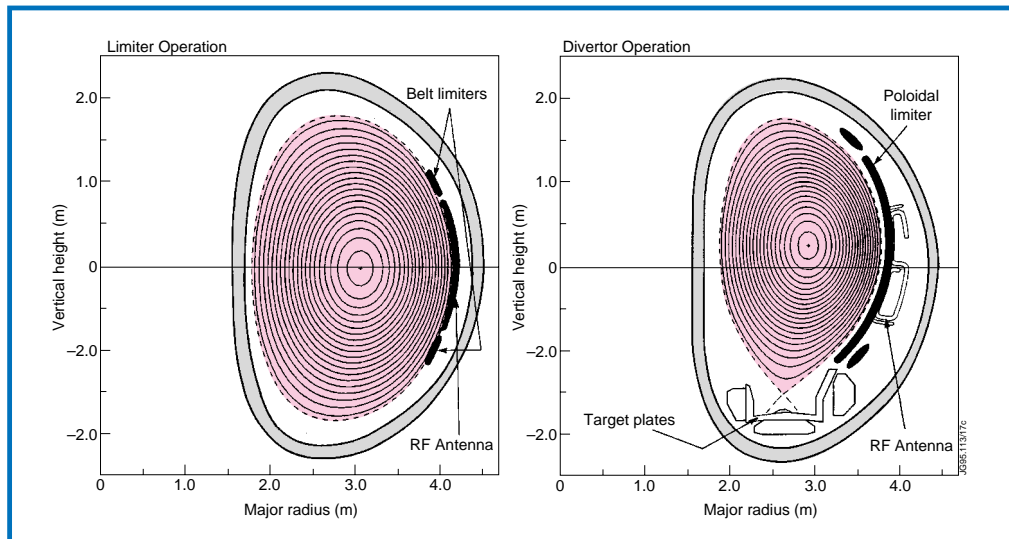

- *An active control of the impurities* by means of a **pumped divertor** is now the most promising solution to accommodate plasma exhaust, including helium ash and to control plasma density and impurity

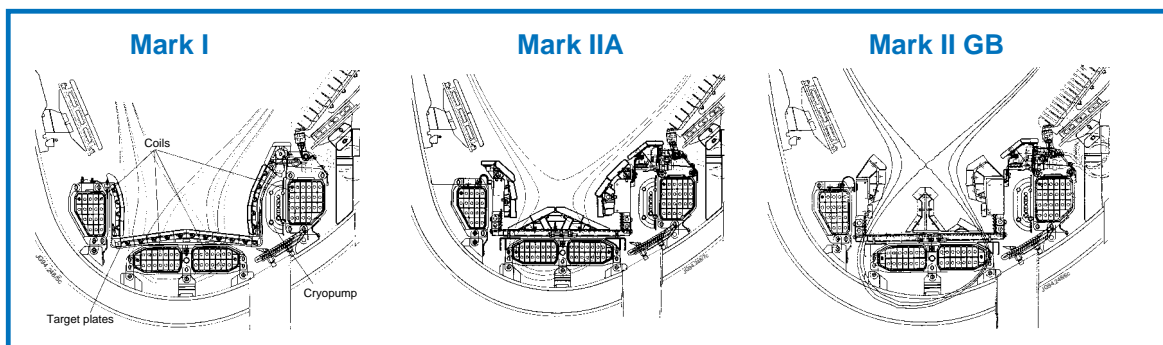

- *Three divertor configurations* were planned and constructed for JET with progressively more closed configuration to enhance particle and impurity retention and study the most suitable configuration for the *ITER divertor*

# Divertor Technology and Construction

## MAIN COMPONENTS OF THE DIVERTOR ARE:

- *Four Freon cooled copper poloidal field coils* contained in a thin iniconel casing, manufactured inside the vessel and installed at the bottom, to establish an X-point in a suitable position



J93.295c



J92.526c/2



J93.34c/5

- The *target plates*, installed above the coils and water cooled, support CFC or Be tiles, which collect the power released from the plasma
- The toroidal *cryo-pump*, anchored to the outer coil, permits control of the plasma density in the divertor region

# Divertor Technology and Construction

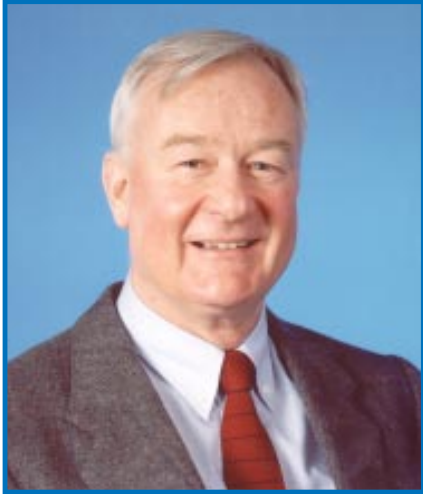

92.320/8

The JET programme of Divertor studies, impurity control and performance enhancement was led by **M Keilhacker** director of the JET Joint Undertaking (1992 to present)

## ADDITIONAL WORK

- New first wall assembly: *4 pairs of RF antennae, 12 discrete outer poloidal limiters, 16 inner wall guard limiters*, all covered with *graphite tiles (+Be evaporation)*



95.16404

- Many new and relocation of most existing diagnostics
  - New **power supplies** for the divertor coils, plasma vertical control and reactive power compensation
  - New **plasma control**, based on the control of the plasma boundary in real time
  - New computerised **coil protection system**
- Complete *refurbishing of Control and Data Acquisition System*, by replacing the original specialised proprietary system with a modern industry standard network

# Mark I Divertor Results

## THE DIVERTOR WORKS:

- In H-mode configuration *without divertor* 15MJ of energy injected into the plasma lead to a 'carbon bloom', while *with divertor* 180MJ or more could be injected without plasma deterioration

- Plasma performance was maintained in 'steady state' for 20s ( $40 \tau_E$ ), only limited by machine constraints, at  $Z_{eff} \sim 1$

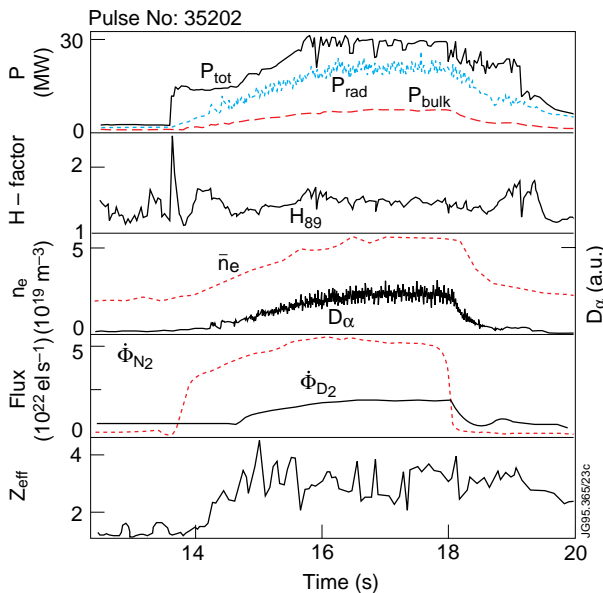
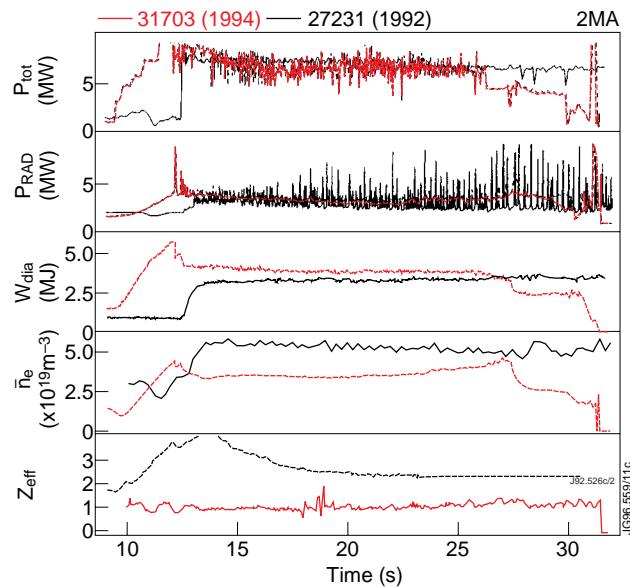

- By injecting a mixture of deuterium and nitrogen into the plasma, radiation can be enhanced to ~80% of the total power loss from the plasma

- In spite of the reduction of the *plasma volume to 80%* with divertor, global plasma performance was maintained:  $n_i \tau_E T_i \sim 1.0 \times 10^{21}$  [m<sup>-3</sup>keV] and  $Q_{DT} \sim 1$

# Construction of the Mark IIA Divertor

- Designed to minimise in vessel work for **modification of the divertor configuration**. Moreover the design was made compatible with **remote handling techniques** for intervention after a D-T experimental campaign (DTE1)
- New inconel water cooled continuous **toroidal tray**, acting as a precise support structure to allow accurate alignment of the divertor target tiles

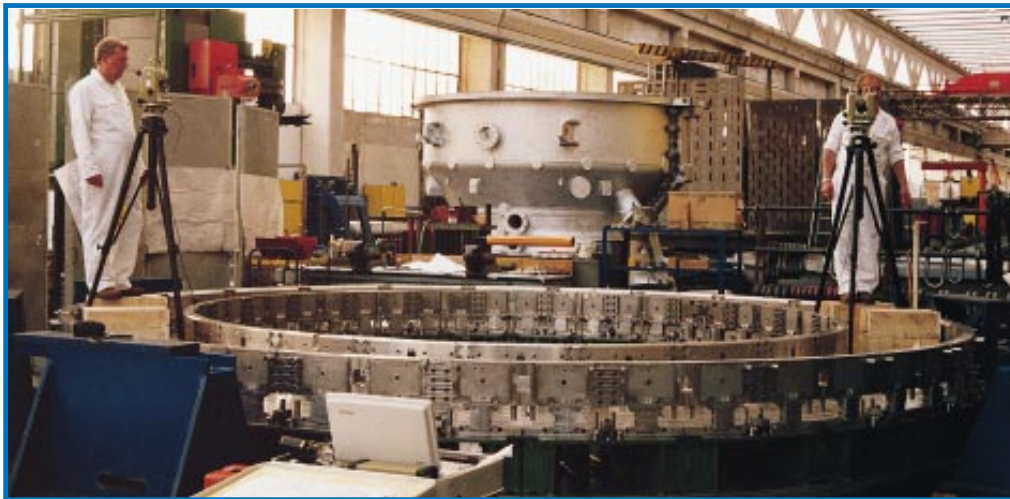

J92.5266/2

- 20% of the tile carrier was installed, using the **RH techniques**, as part of the learning process for subsequent RH interventions after DTE1

- **Inconel tile carriers** and **CFC tiles**, designed for easy replacement by remote handling tools

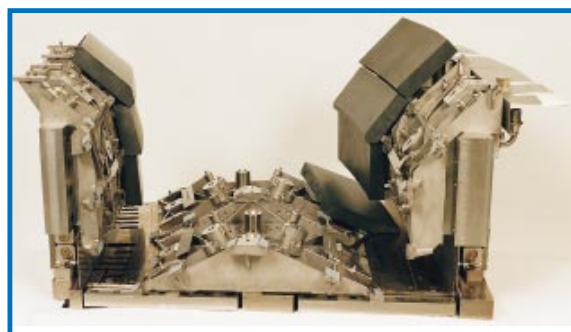

J92.5266/2

# Results with Mark IIA

- *Global performance* in ELM-free H-mode are *similar* for Mark I and Mark II

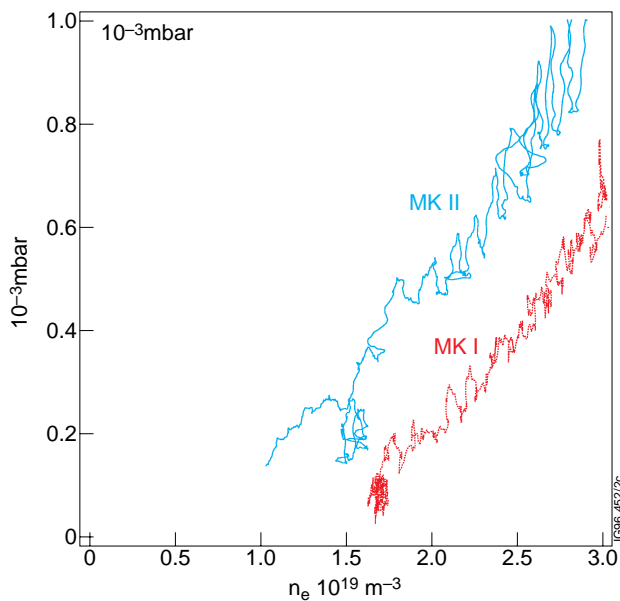

- Increase by a factor of two of the hydrogenic neutral pressure at the pump, indicating a *more effective retention of neutrals in the divertor region*

- Establishment of an *Internal Transport Barrier (ITB)* in *shear optimisation scenarios*, effecting a large part of the plasma volume, reaching peak values of  $T_e \sim 16\text{keV}$  and  $T_i \sim 30\text{keV}$

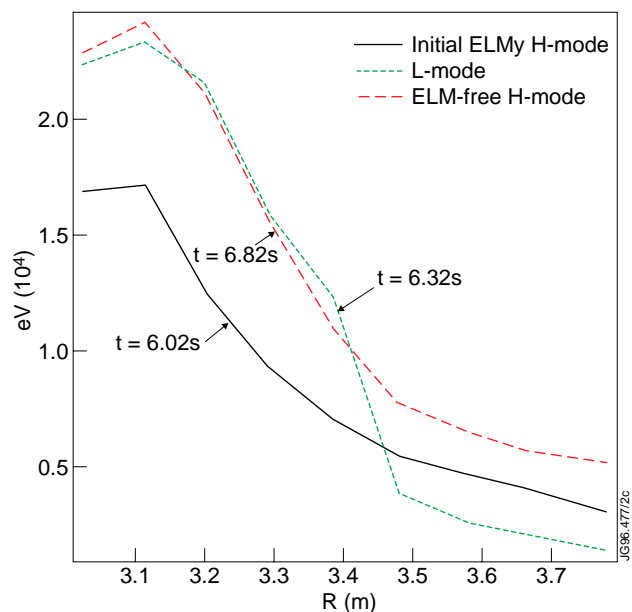

# Deuterium-Tritium Experiment 1

The final quarter of 1997 following months of intensive preparation, saw the fulfilment of the original designers hopes for JET. Using optimal fuel mixtures (50%D-50%T) JET set several world records

The campaign attracted **public attention** first on September 22<sup>nd</sup> when peak powers over **12MW** were reached.

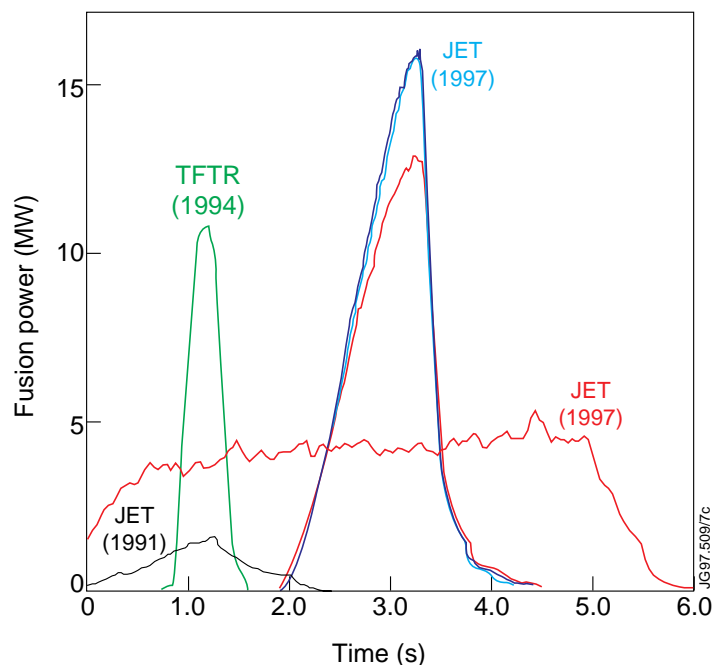

Numerous successful experiments set records for peak fusion power and fusion energy.  $Q_{DT}$  reached 0.65 in steady state, 0.9 transiently



# DTE1 Objectives

## ITER RELEVANT

- *Isotope effects* in ITER-like ELMy H-mode
  - Energy confinement time
  - H-mode threshold
- **Heating**
  - Evaluate ICRF heating schemes

## FUSION PERFORMANCE

- *Maximum fusion power* ( $\geq 10\text{MW}$ ) and Q in
  - Hot-ion ELM-free H-mode
  - Optimised shear mode
- **Evidence of alpha particle heating**
- High fusion power and Q in *steady-state ELMy H-mode*

## TECHNOLOGY

- Demonstrate an ITER scale *D-T processing plant* operating on-line with a Tokamak
- Carry out a *remote handling* divertor tile carrier exchange

# D-T Technologies

- D-T technologies were developed in JET from the early design phase
- Principal D-T technologies are:
  - The **Active Gas Handling System**, capable of re-processing the exhaust fuel, to clean and regenerate it for use in subsequent experiments

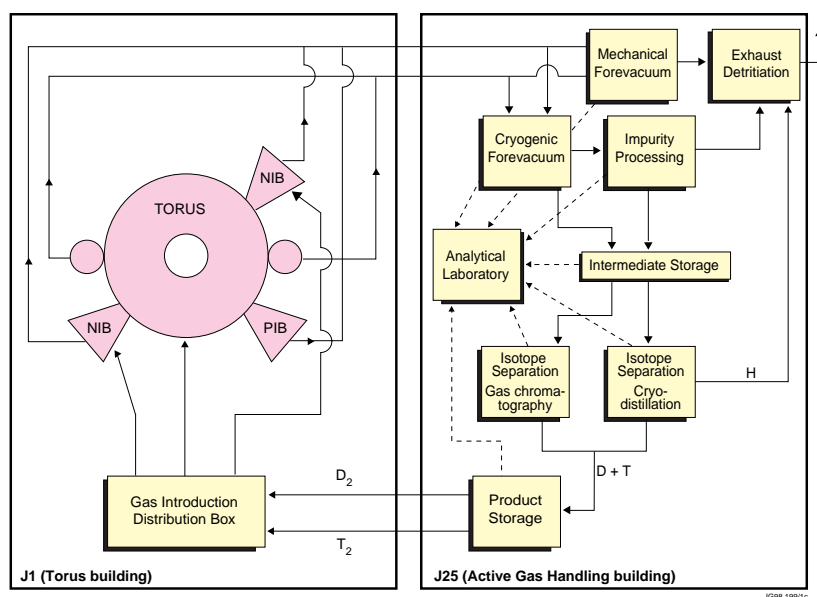

- A wide range of **Remote Handling** transporters, tools and proven procedures, for in-vessel and ex-vessel intervention in active conditions



- The key RH tool is the **Mascot IV servomanipulator**, using the man-in-the-loop technique, essential for unscheduled interventions

# D-T Main Results

Three scenarios have been extensively studied, reaching world record values in plasma performance

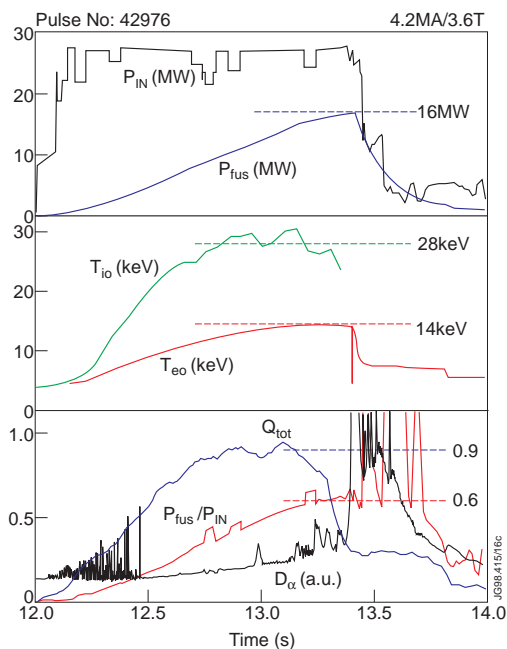

## 1) ELM-FREE H-MODE:

- 16MW of fusion power
- Fusion energy 13.8MJ
- $Q = P_{fus}/P_{in} = 0.62$
- Transient:

$$Q_{tot} = P_{fus}/(P_{in} - dW/dt) = 0.94 \pm 0.17$$

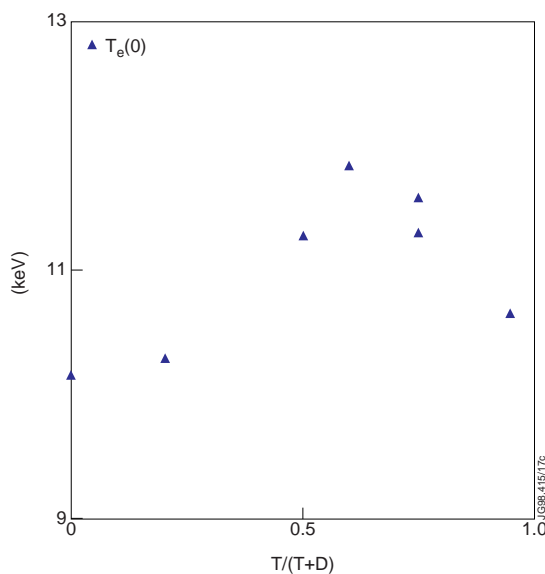

### • Evidence of alpha particle heating:

- The peaking of the electron temperature in the D to T scan, at 50–60% clearly indicates alpha heating (~1.4keV and 1.5MJ)

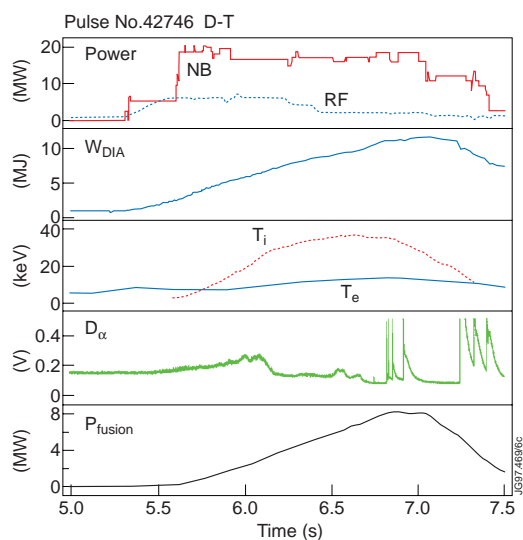

## 2) OPTIMISED SHEAR REGIME:

- 8.2 MW of fusion power
- Higher performance not achieved because the L-mode to H-mode transition in D-T occurs at lower input power than in D-D

# D-T Main Results

## 3) ELMY H-MODE: (ITER SCENARIO)

- 4.5MW of fusion power for >5s
- 21.7MJ of fusion energy
- $Q = P_{\text{fus}}/P_{\text{abs}} = 0.2$
- $T_e = 8\text{keV}$

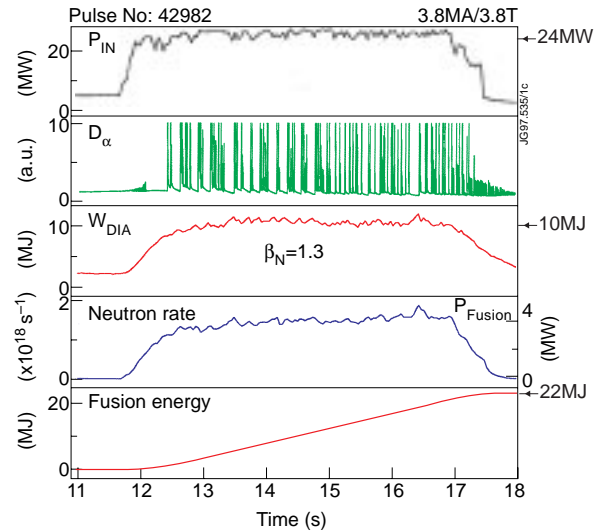

## ITER SIMILARITY PULSES ( $\rho^*$ SCALING):

- Good fit with ITER EPS97 ELMY H-mode scaling
- Extrapolates ignition in ITER

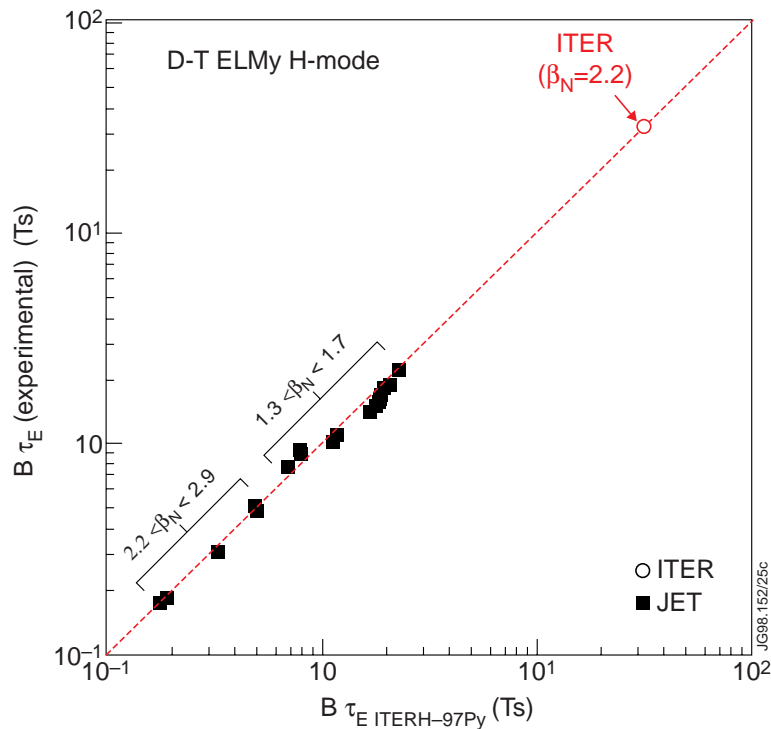

# Remote Handling after DTE1

Remote handling was always a key part of the planning of JET. In the first half of 1998 this important technique was used to carry out a **fully remote handling replacement of the MkIIA divertor with the MKIIGB assembly**. This operation clearly demonstrated that complex rebuild and maintenance operation can be remotely executed in the environment of a fusion reactor. Moreover they can be completed efficiently and in accordance with planned time schedules

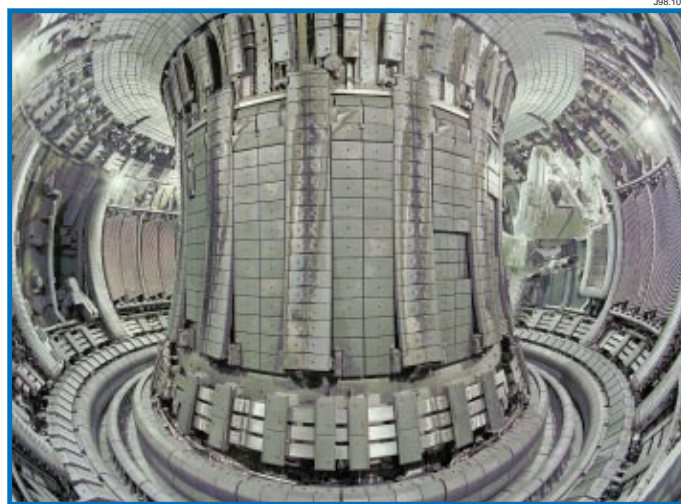

The system had to exchange **144 tiles** and tile carriers for **192 new** ones and demonstrated its design ability to tackle unplanned situations

The **“man-in-the-loop”** concept gives the operator a sense of presence inside the torus



# Upgrades to end 1999

- The **Mark IIGB** divertor configuration has been fully installed by RH techniques
- The completion of engineering analysis studies and tests on samples will allow increase of the **toroidal magnetic field** from 3.4T to 4T

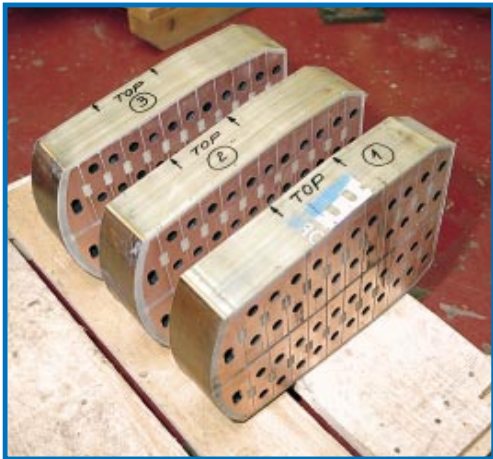

Slices cut out of a faulty toroidal coil, to extract **shear test samples**

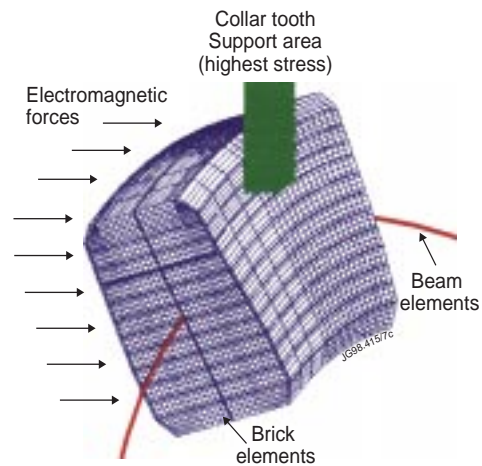

Hybrid model of a TF Coil to assess **shear stresses** in the glass-epoxy insulating bonding

- The centrifuge **pellet injector** will be supplemented with an in-board guide tube to allow injection from the high magnetic field region

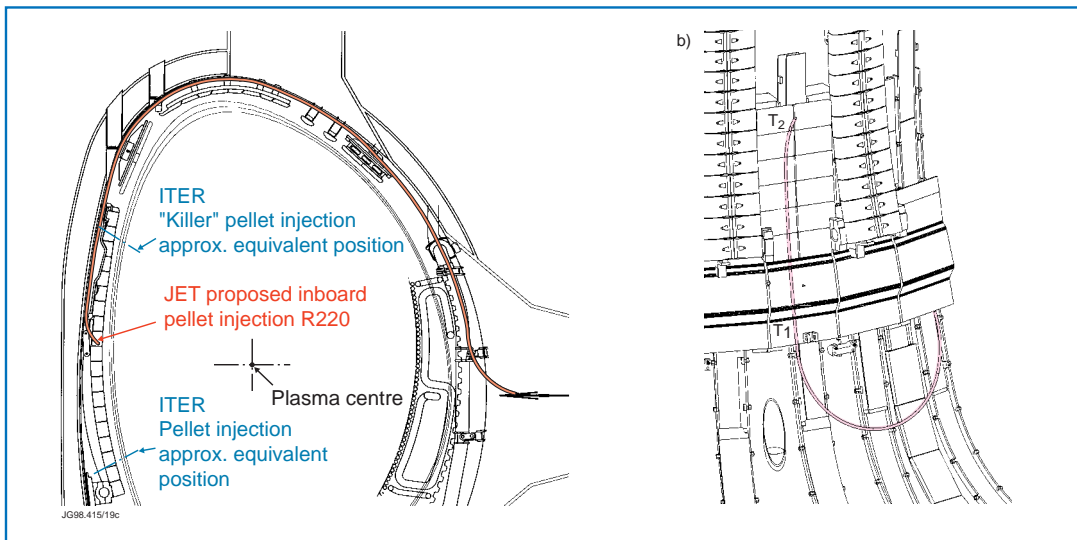

# Experimental Programme

- *Characterise the new divertor configuration* and re-optimize performance in the three key plasma scenarios
- Develop in full *Optimised Shear Regime* scenarios, which are the most promising for ITER scenarios in overcoming the relatively modest ELMy H-mode performance. Possible **performance predictions** are shown in the table

$B_T$	$I_P$ MA	$P_{tot}$ MW	$P_{LHCD}$ MW	$I_{BS}/I_P$	$\beta_N^{(3)}$	$P_{Fusion}^{(2)}$ MW
<sup>(1)</sup> 4.0	3.7	21	0	0.41	2.1	24
4.0	3.7	21	3.5	0.60	2.7	38

JG98.415/13c

(1) Prolong L-mode and combine with grassy ELMy H-mode  
(as in several JET DD and DT pulses)

(2) Fusion power assume to scale as  $\beta_N^2$

(3) Max  $\beta_N$  can be further optimised by profile control

- *Take full advantage* of the **4.0T toroidal magnetic field** capability to increase global performance and possibly use the *in-board pellet injection* to approach the Greenwald density limit
- Possibly perform in late 1999 a new *D-T campaign* to reassess JET plasma performance with the *Mark IIGB* divertor at 4T magnetic field

Key objectives would be:

- $Q = 1.5$
- Alpha particle heating
- Confinement studies

# Proposed Post 1999 Upgrades

- Increasing of **additional heating power** by **7MW of NB** and **3-5MW of ICRF**, to study ITER physics in a wider range and dimension-less parameters
- Installation of **new diagnostics** for more accurate studies of the edge and of the ITB physics and alpha particles effects
- Possible replacement of graphite with **beryllium tiles** on the **first wall**, with **divertor tiles** in **CFC** or in **high Z materials**, to reproduce the first wall foreseen in the present ITER design

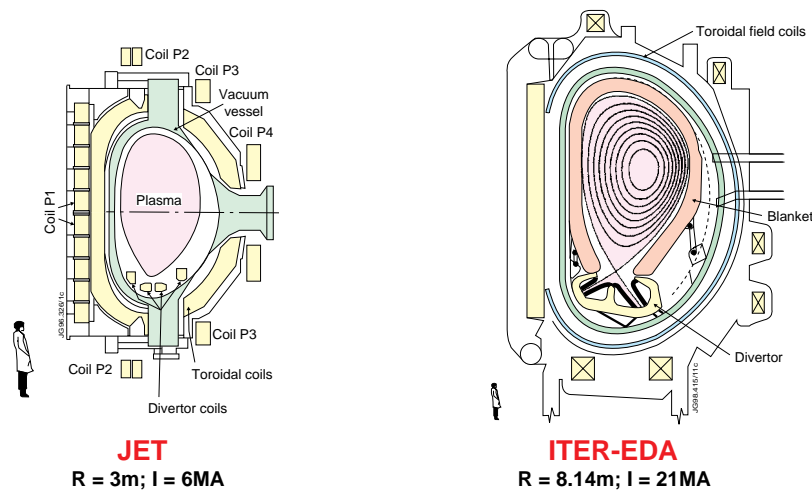

Poloidal Cross-sections of JET and ITER

## JET Beyond 1999

- JET has still ample possibility for **further engineering upgrading** and development to test new physics ideas
- It is widely recognised world-wide that **JET has unique features and potentials** to provide further key physics and engineering knowledge on the road toward a fusion reactor
- Therefore serious consideration is being given by the European Fusion Programme, to **extend the use of the JET facilities beyond 1999 under a new organisational framework**.





# JET Site



J91.239c

- JET is situated in the Oxfordshire countryside near Abingdon (United Kingdom)
- From the top (North) to bottom (South):
  - 400kV/33kV substation
  - Outdoor power supplies (NBI, ICRF, LHCD)
  - Indoor power supplies (TF, PF, Divertor coils)
  - Main building: Tritium building (far left), JET Tokamak Hall (left), Assembly Hall (right)
  - Control Room
  - Office buildings

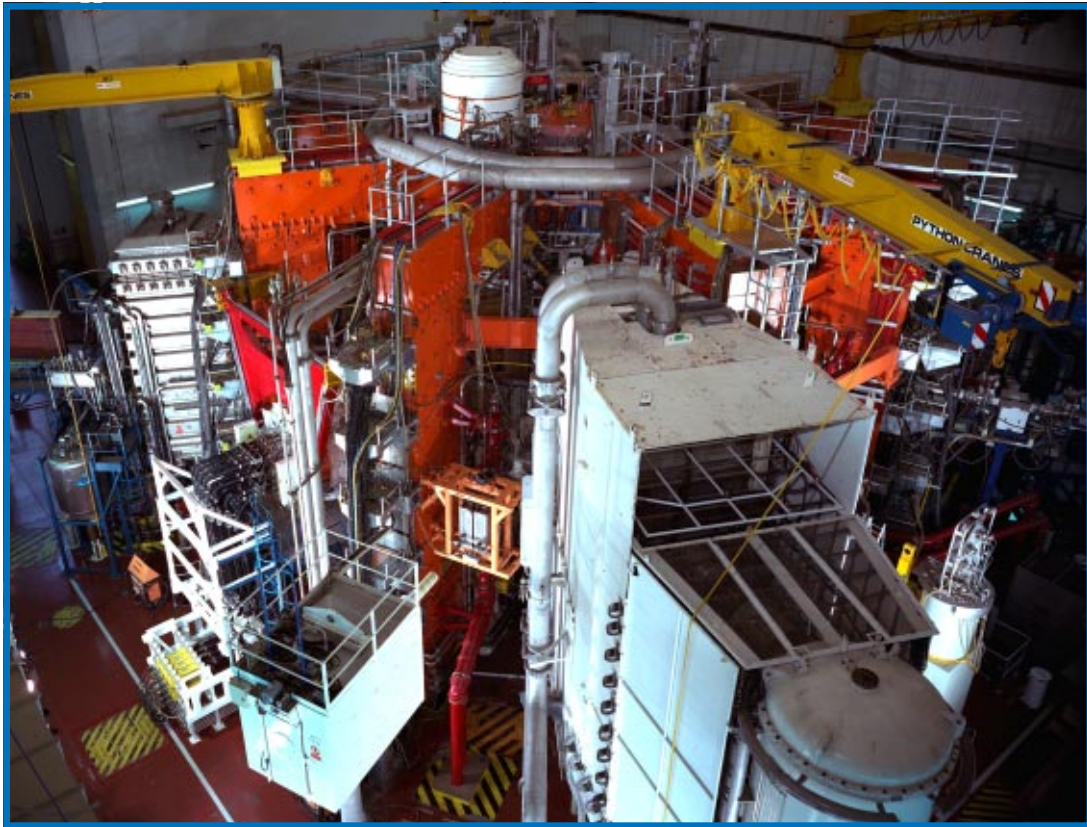

J91.212c