

Interpretative Modelling of JET's Thermal Helium Diagnostic

Y Andrew¹, S J Davies, D Elder², L D Horton, G F Matthews,
A Meigs, P D Morgan, M O'Mullane³, M Stamp, R Prentice,
P C Stangeby².

JET Joint Undertaking, Abingdon, Oxfordshire, OX14 3EA,

¹Imperial College of Science, Technology and Medicine, London, SW7 2BZ, UK.

²and Institute for Aerospace Studies, University of Toronto, Toronto, Canada.

³and University of Strathclyde, Glasgow, G4 0NG, UK.

"This document is intended for publication in the open literature. It is made available on the understanding that it may not be further circulated and extracts may not be published prior to publication of the original, without the consent of the Publications Officer, JET Joint Undertaking, Abingdon, Oxon, OX14 3EA, UK".

"Enquiries about Copyright and reproduction should be addressed to the Publications Officer, JET Joint Undertaking, Abingdon, Oxon, OX14 3EA".

ABSTRACT

Electron density, n_e , and temperature, T_e , in the MkIIa divertor have been measured using neutral helium line ratios. Experimental evidence indicates that the spectroscopic signal for helium injected from the vertical target is dominated by recycling. When helium is injected from the horizontal target it is possible to differentiate between injected and recycled spectral sources. To determine the spatial location of the neutral helium emission, and hence of the n_e , T_e measurements, an interpretative model has been developed which uses the impurity/neutral codes, DIVIMP/NIMBUS, the atomic database ADAS and the diagnostic lines of sight. Measurements and simulations have been performed using the various injection points over a range of target conditions. Comparisons with other divertor diagnostics, such as the divertor interferometer and target Langmuir probes are presented.

1. INTRODUCTION

Electron density, n_e , and temperature, T_e , can be deduced from measured neutral helium, He I, line ratios (667.8 nm/728.3 nm) and (728.3 nm/706.1 nm) respectively, by comparison with collisional radiative model calculations [1,2]. This paper presents a study of the spatial distribution of He I emission in the JET divertor plasma and of the validity of the technique under various plasma conditions. Using He I line intensity measurements, it has been possible to identify the conditions in which emission from injected or recycled helium sources dominate. To determine the spatial location of the measured n_e and T_e , an interpretative model has been developed using 2-D Monte-Carlo codes DIVIMP/NIMBUS [3,4] coupled with the atomic database ADAS[5]. Comparisons are also made with other divertor diagnostics.

2. EXPERIMENTAL MEASUREMENTS

The intensities of the three He I lines were measured in the JET MkIIa divertor using spectrometers which were aligned to view the helium injection nozzles, see Fig. 1, at different toroidal locations. Details of the spectrometer and the periscope viewing system used to view the base helium injection are given in [1]. The vertical viewing system measured emission from the side helium injection. This comprised twelve vertical lines of sight with a poloidal resolution of 1.3cm and a toroidal

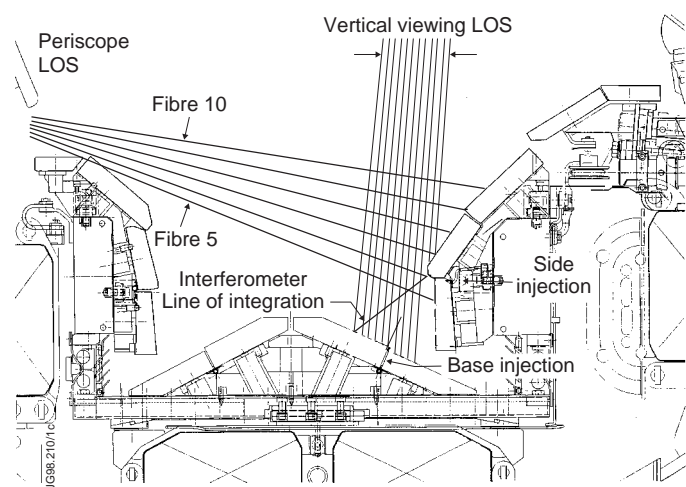

Fig.1 Viewing arrangement for the thermal helium diagnostic in the JET MkIIa outer divertor leg.

resolution of 0.6cm; and a Czerny-Turner 1m spectrometer with a resolution of 0.074 nm/pixel over a spectral range of 87 nm at a sampling rate of 100 ms. In addition, an interference filter, not aligned to the helium injection nozzles, made measurements of the intensity of the 667.8 nm He I line in the outer divertor and was used to provide a measure of the recycled signal. The interference filter has a spectral range of 1.4 nm, a poloidal resolution of 33 cm, a toroidal resolution of 19 cm, and a sampling rate of 2 ms. Helium was injected at a rate of 7 mbar $l s^{-1}$ for typically three seconds through a straight pipe nozzle [1]. Recent measurements [6] show this nozzle to have a divergence of $\sim 32^\circ$ FWHM.

2.1 Ohmic pulse 39885 with side helium injection

During this ohmic pulse, \bar{n}_e reached a constant value of $2 \times 10^{19} m^{-3}$ after the formation of the X-point, with the strike points being swept over the horizontal target with an amplitude of ± 6 cm at 4 Hz. Helium began to be puffed into the outer divertor from the side nozzle at 13 s and both the aligned vertical viewing spectrometer and the interference filter measured an increase in the 667.8 nm line intensity at 14 s, as shown in Fig. 2. It was not possible to distinguish the injected He I signal from the recycled He I signal; there was no fall in the He I line intensity measured by the aligned observation system after helium stopped being puffed into the divertor.

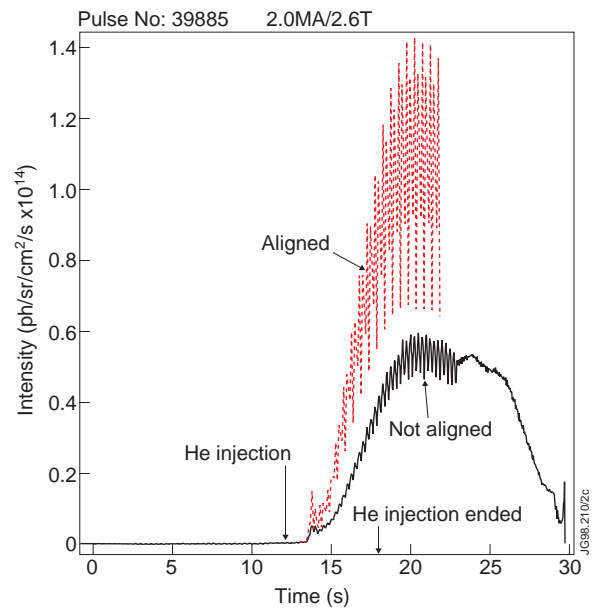

Fig.2 HeI, $\lambda=667.8nm$, intensity measured with the vertically viewing spectrometer and with the interference filter, in the ohmic pulse 39885.

2.2 Ohmic pulse 37996 with base helium injection

In this vertical target ohmic pulse, \bar{n}_e reached a peak of $2.3 \times 10^{19} m^{-3}$ at 24 s. Helium was injected in three, one second gas puffs from the outer base nozzle into the private plasma at 15 s. Since fibres (1 - 4) of the periscope viewing system were occluded, only fibres 5 - 10 made measurements in the MkIIa divertor plasma. Both the periscope viewing system, aligned to the base injection, and the interference filter measured an increase in He I 667.8 nm line intensity at ~ 16 s. Note that the signal measured by the periscope viewing system fell sharply each time helium puffing stopped, while the recycled helium emission remained at its peak value, as shown in Fig. 3. It was also observed that the fall in helium line intensity, became smaller with subsequent gas puffs, as the level of recycling increased. In order to quantify the contribution of the recycled helium emission to the periscope measured signal, both the periscope and interference

filter measured line intensities, shown in Fig.3, were normalised to values reached after helium puffing ended. The interference filter signal was used to estimate the contribution of recycled He I emission to the periscope measured signal, by comparing the two normalised intensities. It was found from these comparisons that the signal measured by the periscope viewing system comprised $\sim 20\%$ recycled helium emission during the early part of the first puff and $\sim 80\%$ during the last.

3. INTERPRETATIVE MODELLING

More precise knowledge of the spatial distribution of the He I spectral emission is essential for the interpretation of the measurements.

This is achieved through simulations of plasmas using the 2-D Monte-Carlo codes DIVIMP and NIMBUS. The 2-D hydrogenic plasma was calculated using the Onion Skin Model [3] within DIVIMP, with target Langmuir probe measurements providing the boundary conditions, assuming the ion temperature, $T_i = T_e$ at the target in each case. Converged plasma solutions were reached after iterating with NIMBUS to obtain hydrogen ionisation distributions. The general agreement between the calculated and measured diagnostic signals, such as the target $D\alpha$ profile, was used to validate the calculated hydrogenic plasma.

3.1 Ohmic pulse 39885 with side helium injection-recycled source

Helium atoms were launched in the simulation from the vertical divertor target, corresponding to the location of the side injection, with an assumed temperature of 0.04 eV equivalent to the tile temperature. For the case of recycled helium, the injected atoms continued to be tracked following their subsequent stages of ionisation. Helium neutrals and ions striking the vessel walls above the target, were reflected, retaining the same energy as they had before impact. The divertor target recycling coefficient for helium was set to one. It was assumed that helium ions hitting the target were neutralised and subsequently returned to the plasma as a result of re-emission and reflection [7,8]. As an approximation to these two processes, helium particles arriving at the target were re-released as atoms with temperatures of (a) 0.04 eV and (b) 11 eV (the average target T_i) in two separate cases with the same background plasma.

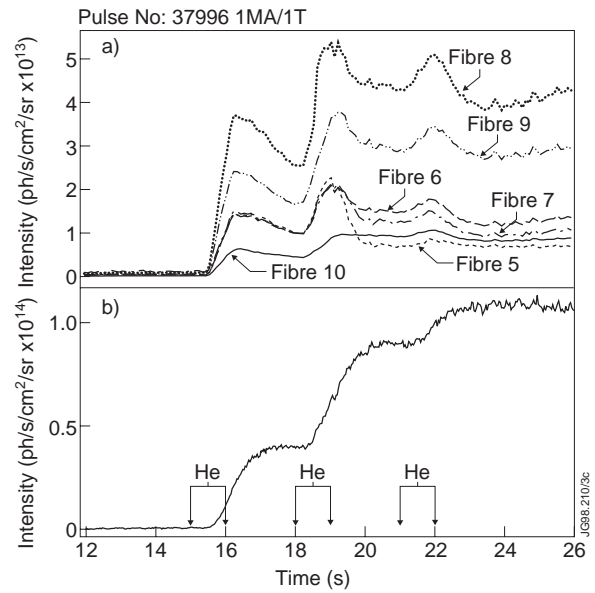

Fig.3 He I, $\lambda=667.8$ nm, intensity measured with (a) the periscope viewing system and with (b) the interference filter, in the ohmic pulse 37996.

Radial profiles of the He I line intensities measured with the vertically viewing spectrometer were compared with radial profiles calculated with the model using data as in [9,10]. Since helium was treated as a recycling impurity, all results have been normalised to the peak values to allow comparison of the radial profiles. A much closer match to the measured radial profiles was obtained by allowing the injected neutral helium to recycle, see Fig.4. Using an injected helium source in the simulation, where injected atoms were ignored once ionised, did not match the experimental profiles. A particle reflection coefficient, $R_N = 0.5$, rather than the value calculated from [11,12], was needed to obtain an improved match with the experimental measurements. The general agreement between the two was found to be reasonable, as shown in Fig. 4 for $\lambda = 728.3\text{nm}$, with some underestimation by the code of the line intensities in the private plasma. The differences in this region could be attributed in part to inaccurate modelling of the hydrogenic plasma [1]. The error bars on the calculated line intensity profile indicate the sensitivity of the simulated He I line intensity to uncertainties in electron impact excitation rate coefficients [13].

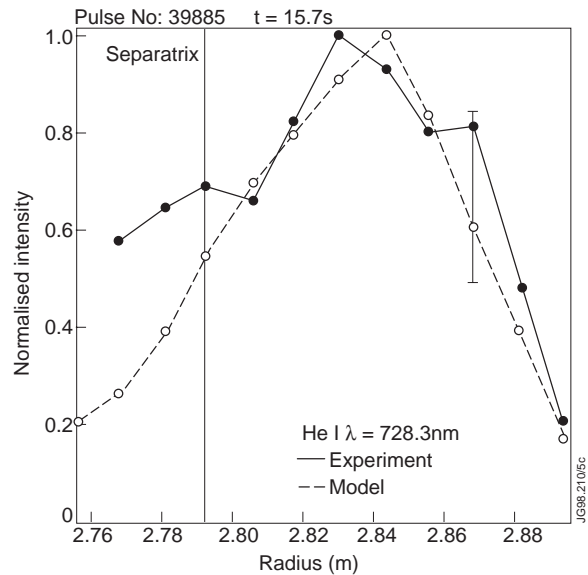

Fig.4 Comparison of normalised measured and calculated HeI 728.3nm line profiles for the vertically viewing spectrometer in an ohmic plasma with side injection.

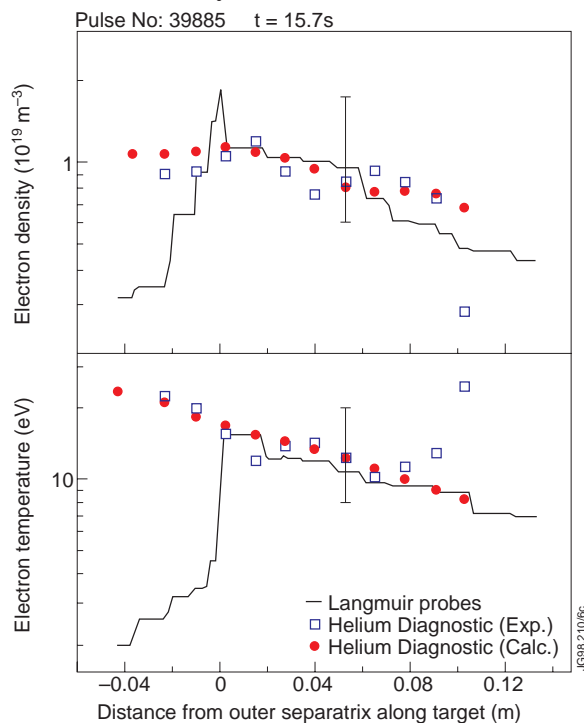

Fig.5 Comparison of experimental n_e and T_e profiles measured with Langmuir probes at the outer target plate (straight line) with values derived from measured and calculated He I line ratios, for the ohmic pulse 39885.

Results from the simulation indicate He I emission to be concentrated in a region very close to the outer divertor target, for all three spectral lines. One would expect the measurement of He I line intensity ratios over such a localised region to give values of n_e and T_e representative of the target conditions. In Fig. 5 the values of n_e and T_e derived from the DIVIMP calculated He I line ratios are compared with the target Langmuir probe measurements (used as input to the code). The close agreement between the two sets of data, demonstrates the effects of line integration to be minimal in the simulation, allowing localised measurements of n_e and T_e to be made. Also shown in Fig.5 are the values of n_e and T_e derived from experimentally measured He I line

ratios. Since the simulation reproduces the experimental measurements so well it can be concluded that the experimental values represent target electron density and temperature. The difference between the Langmuir probe and helium diagnostic measurements in the private plasma region are expected to be due to an extended helium recycling source and the resulting effects of line integration.

3.2 Ohmic pulse 37996 with base helium injection-injected source

The ohmic plasma with base helium injection was simulated during the first helium puff, at which time very similar conditions were measured by the Langmuir probes at the inner and outer strike points, i.e. $T_e = 10$ eV and $n_e = 8 \times 10^{18} \text{ m}^{-3}$. Two simulations were performed using the same background plasma, to account for He I emission from injected, where the atoms were only followed until ionisation, and recycled sources. The magnetic geometry was such that the LOS 5-7 intersected with the separatrix below and close to the X-point, while the LOS 8-10 made measurements above it. It was not possible to constrain the helium simulation using the measured line intensity profiles in the same way

as described for the vertical viewing system due to uncertainties in the fibre to fibre calibration. The matching of the calculated and measured He I line ratios were used as a constraint on the simulation. Agreement between both sets of line ratios were found to be within the sensitivity of the calculations to uncertainties in the atomic data. The n_e and T_e values derived from the DIVIMP calculated and measured line ratios, therefore, also agreed to within the sensitivity to uncertainties in the atomic data, as shown in Fig. 6. The simulation indicates that the region of strongest He I emission was close to the strike point and some distance along the separatrix, as demonstrated in [1]. However, close to and above the X-point, within the field of view of the periscope fibres, the calculated He I emission was spatially extended for both injected and recycled sources. From these results it was concluded that the values of n_e and T_e measured using He I line ratios close to and above the X-point, in this vertical target configuration, were non-local.

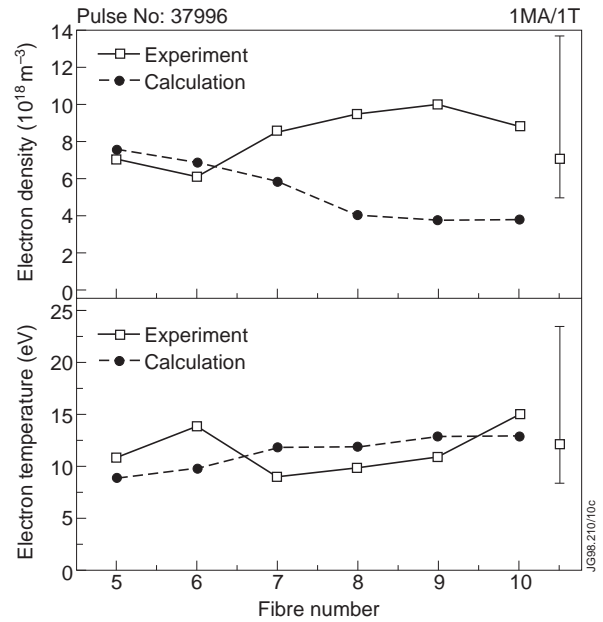

Fig.6 Comparison of n_e and T_e values derived from measured and calculated He I line ratios, for the ohmic pulse 37996.

3.3 H-mode pulse 39990 with recycled helium

This discharge was used to investigate the region of helium diagnostic measurements under high density, additionally heated, attached conditions. Following the application of 10 MW of NBI at 17 s to this plasma, \bar{n}_e increased to a peak value of $8 \times 10^{19} \text{ m}^{-3}$ at 21 s. From 18.5 s onwards regular ELMs were observed with a frequency of ~ 2 Hz. Helium was injected in the outer SOL from the side and base nozzles from 15 s to 18 s. During the steady state phase of the H-mode, helium puffing had ended and recycled He I emission was measured. A time slice was chosen in between ELMs during a steady state phase of the pulse, when \bar{n}_e was close to its peak value.

For the helium simulation, the injected atoms were allowed to recycle with temperatures of 0.05 eV, for the thermally re-released helium, and 15 eV, for backscattered helium. Using $R_N = 0.5$ again gave radial helium profiles which compared very well with the vertical viewing spectrometer, as shown in Fig. 7, for the 667.8 nm line.

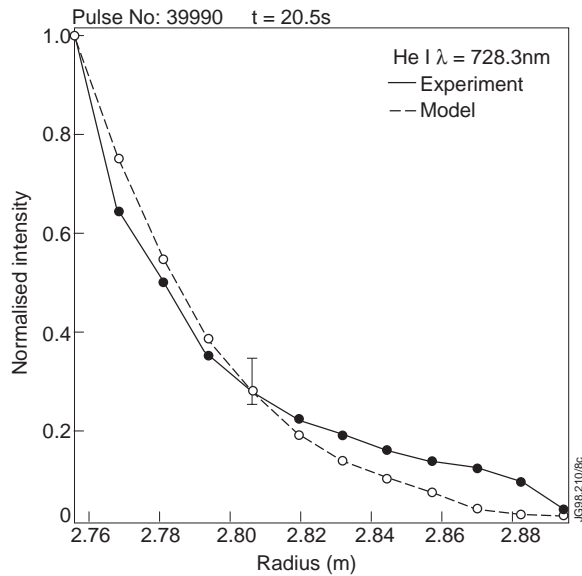

Fig.7 Comparison of calculated and measured HeI, 667.8nm, line profiles for the vertically viewing spectrometer in an H-mode discharge.

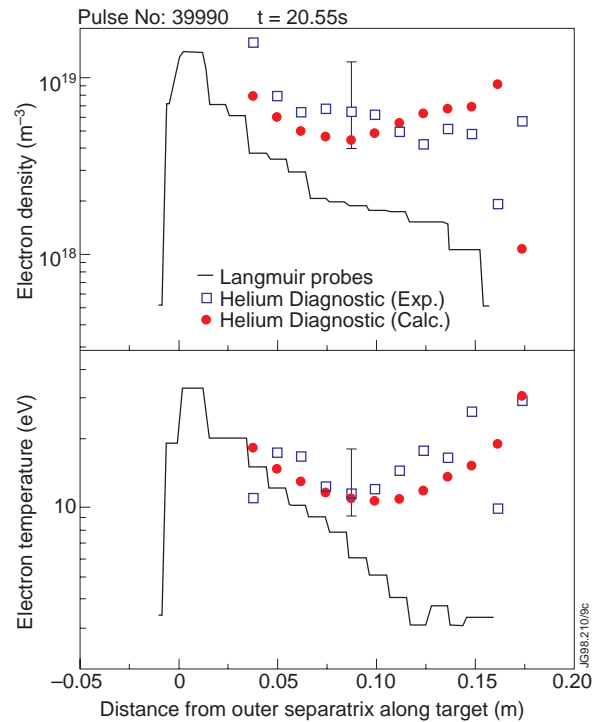

Fig.8 Comparison of experimental n_e and T_e profiles measured with Langmuir probes at the outer target plate (straight line) with values derived from measured and calculated He I line ratios, for H-mode pulse 39990.

The simulation shows the He I emission to be most intense and localised close to the strike point. With increasing (radial and poloidal) distance from the strike point, the region of emission became spatially extended. The n_e and T_e values shown in Fig. 8 are derived from simulated and measured He I line ratios for the vertical viewing system. The measured values were reproduced well by the simulation. Also shown in Fig. 8 are the Langmuir probe measurements, used as input to the code. Within ~ 8 cm of the strike point, n_e and T_e derived from He I ratios were in

reasonable agreement with the Langmuir probe measurements. However, with greater radial distance the helium diagnostic measurements increased with distance from the strike point as a result of the extended region of He I emission. Measurements of average divertor n_e and T_e made above the X-point with the periscope were reproduced by the calculated simulation to within the sensitivity to uncertainties in the atomic data.

4.0 COMPARISON WITH OTHER DIAGNOSTICS

Comparisons of the helium diagnostic with Langmuir probes have been discussed in Sections 3.1 and 3.3. The only other measurement available in the outer divertor plasma with which to make comparisons, was the line integrated density measured by the divertor interferometer, see Fig. 1. An exponential decay length of 13.3 cm at the target was derived from the helium diagnostic n_e measurements at 15.7 s, in the ohmic plasma 39885. This value was used to integrate over a distance of 27 cm, equivalent to the length of the line of integration of the divertor interferometer. The helium diagnostic gave a value of $1.3 \times 10^{18} \text{ m}^{-2}$ ($\pm 89\%$) compared with a value of $1.4 \times 10^{18} \text{ m}^{-2}$ ($\pm 9\%$) measured by the divertor interferometer at 15.7 s. The agreement is well within the errors of both measurements, but does not take into account the variation along the field lines of n_e measured by the interferometer in the outer SOL. Results from the simulation, indicate that n_e decreases by $\sim 6 \times 10^{17} \text{ m}^{-3}$ along the field lines from the target up to the maximum poloidal height of the interferometer line of integration, and as a result would not have a significant effect upon the line integrated density derived from helium diagnostic measurements.

5.0 CONCLUSIONS

It has been found experimentally that measurements made using the side injection/vertical view arrangement are dominated by recycled He I emission. In the base injection/periscope view arrangement emission from the injected helium could be decoupled from the background recycled helium emission. An interpretative model using the DIVIMP/NIMBUS 2-D Monte-Carlo codes has been developed to simulate He I spectral emission from both sources. Results from the simulation suggest that under ohmic conditions, recycled He I emission is concentrated in a thin layer across the SOL divertor target. This is consistent with the good agreement found between values of n_e and T_e derived from the vertical viewing spectrometer and Langmuir probe measurements. The helium diagnostic showed close agreement with the divertor interferometer, under ohmic conditions. Simulation of the periscope viewing arrangement indicates the values of n_e and T_e measured close to and above the X-point were non-local measurements. Under H-mode conditions the simulations indicate recycled helium to have given rise to localised He I emission only in the vicinity of the strike point. This was also consistent with comparisons made with Langmuir probe measurements in which helium line ratios gave significantly higher values of n_e and T_e at radial distances greater than 8 cm from the separatrix.

Errors in the atomic data have been identified as a major limitation in the simulation of helium emission. Improvement in the database will allow more stringent conditions to be placed on the calculations. Extension of the model to include helium emission under detached plasma conditions will also be part of future work. In the MkII-GB divertor the helium injection locations will allow localised measurements close to the X-point to be made.

6.0 ACKNOWLEDGEMENTS

The authors would like to acknowledge the collaboration with TEXTOR, at KFA, Jülich and in particular Mathias Brix for his work on the program used to derive n_e and T_e from He I line ratios under JET Agreement No.525. Financial support for Y. Andrew from EPSRC and JET Joint Undertaking is also gratefully acknowledged.

7.0 REFERENCES

- [1] S.J. Davies, J. Nucl. Mater. 241-243 (1997) 426-432.
- [2] B. Schweer, et al., J. Nucl. Mater. 196-198 (1992) 174-178
- [3] P.C. Stangeby and J.D. Elder, J. Nucl. Mater. 196-198 (1992) 258.
- [4] E. Cupini, A. De Matteis, and R. Simonini, NET Report EUR XII (1984) 324/9.
- [5] H.P. Summers, ADAS, JET-IR(94) 06 (1994).
- [6] Measurements performed by P. Kornejew, IPP, Berlin (1997).
- [7] J. Wesson, Tokamaks, 2nd Edition, Clarendon Press-Oxford (1997).
- [8] H.H. Abou-Gabal, G.A. Emmert, Nucl. Fusion 31 (1991) 3.
- [9] V.A. Abramov, et al., Recommended Cross-sections and Rates for Inelastic Collisions with Helium Atoms, I.V., Kurchatov Inst. of Atomic Energy, Moscow, (1987).
- [10] B. Brosda, PhD. Thesis (Ruhr-Universität, Bochum 1993).
- [11] W. Eckstein, H. Verbeck, in *Compendium for Plasma Surface Interactions, Special Issue* 1984, Nucl. Fusion (1984) 12.
- [12] E.W. Thomas, R.K. Janev, and J. Smith, J., Nucl. Inst. and Methods in Physics Research B69 (1992), 427-436.
- [13] Y. Andrew et al., to be published.