

G F Matthews et al

Ion Optics Evaluation of the Plasma Ion Mass Spectrometer (PIMS) Designed for the JET Tokamak

Ion Optics Evaluation of the Plasma Ion Mass Spectrometer (PIMS) Designed for the JET Tokamak

G.F.Matthews¹, W.Schustereder², N.Cant¹, S.K.Erents¹, J.Vince¹,
A.Qayyum², C.Mair², P.Scheier², T.D.Märk²

¹UKAEA/Euratom Fusion Association, Culham Science Centre, Abingdon, Oxon OX14 3DB, UK

²Leopold-Franzens-University of Innsbruck, Institute for Ionphysics, Technikerstr. 25, A-6020
Innsbruck

Paper submitted for Journal of Mass-Spectroscopy

“This document is intended for publication in the open literature. It is made available on the understanding that it may not be further circulated and extracts or references may not be published prior to publication of the original when applicable, or without the consent of the Publications Officer, EFDA, Culham Science Centre, Abingdon, Oxon, OX14 3DB, UK.”

“Enquiries about Copyright and reproduction should be addressed to the Publications Officer, EFDA, Culham Science Centre, Abingdon, Oxon, OX14 3DB, UK.”

ABSTRACT

Computer simulations of a design for a Plasma Ion Mass Spectrometer (PIMS) head for diagnosing the edge plasma on the Joint European Torus (JET) magnetic fusion experiment are reported. An overview of the design issues is presented along with results of these fully three-dimensional ion optical calculations. By modelling the behaviour of the different impurity ions anticipated in JET, an evaluation of the proposed PIMS geometry has been carried out. The effects of misalignment of the electric and magnetic fields within the PIMS on mass resolution, and the effect of the range of ion temperature and sheath voltage expected in JET on the transmission are described.

1. INTRODUCTION

Until the development of the Plasma Ion Mass Spectrometer (PIMS) there was no device available for measuring the absolute flux of ions in each charge state flowing in the edge plasma of tokamaks (magnetic fusion devices). Besides the knowledge of the local density in the edge region the PIMS can give an indication of the average ion temperature of the impurities [1,2,3]. The charge state distribution and absolute flux of impurities is dependent on the location and magnitude of the impurity sources and the transport of impurity ions within the scrape-off layer (SOL) and on closed flux surfaces.

The benefit of mass spectrometry compared to spectroscopic methods is that a full evaluation of species in the plasma edge can be achieved by this in-situ measurement at a very precisely defined point in space [1,2,3]. These measurements are very relevant for next step magnetic fusion experiments such as ITER (International Thermonuclear Engineering Reactor) [4] since the production and screening of impurities in current tokamaks is still not well understood and ITER will need a low plasma impurity content to reach its fusion energy goals. JET is currently the closest tokamak in size to ITER in operation today and the only machine in which both beryllium and carbon can be used as wall materials as is planned for ITER. PIMS measurements in JET would provide an excellent benchmark for the edge plasma simulation codes and thus improve our predictions for ITER. An example of the data that can be obtained is shown in figure 1. This mass spectrum was obtained in the small DITE tokamak (26 cm minor radius) and shows the large population of high charge state ions which diffuse out of the core into the edge. It also shows that the carbon production in DITE at this time was dominated by chemical erosion of carbon by oxygen.

2. TROCHOIDAL MASS SPECTROMETRY

The PIMS is a trochoidal mass spectrometer that uses the magnetic field for the confinement of the plasma as its B-field. Thus only electrostatic voltages have to be applied. It has been known for a long time that such a configuration has perfect focussing properties for the ion velocity components normal to the magnetic field [5]. Different types of trajectories, i.e. the prolate and

the curvate (Figure 2), can reach the focal point. All trajectories are focussed at the point they re-cross their plane of origin and travelling in the original direction [5] in a distance of:

$$b = \frac{2\pi m_i E}{z_i e B^2} \quad (1)$$

from the source, m_i and z_i being the ion mass and charge, E and B the electric and magnetic fields. Note that b is independent of the initial velocity of the ion.

3. SPECIFIC REQUIREMENTS FOR A PIMS ON JET

The essential criteria for the design of an in-situ mass spectrometer can be summarised as follows:

- The instrument must not be negatively affected by the high magnetic field of the tokamak. In JET the range of toroidal magnetic fields used routinely is 1 to 3.4 T.
- The ion optics has to deal with a wide spread of initial ion velocities since the plasma is a hot ion source.
- A geometry has to be selected which allows transmission for the component of the ion velocity which is parallel to the magnetic field.
- The geometry must be simple so that the relative transmission probability of various ions is straightforward to model, since there is no practical means to calibrate the device.
- The intensity of the ions in the boundary plasma necessitates an attenuating slit to avoid space charge effects that may occur if too much current is extracted into the device. The slit also needs to be not more than a few Debye lengths across, since this is the dimension of the plasma sheath [6], so that there is a well defined transition between the plasma and the extracted ion beam [7].
- The outer shell and entrance slit need to withstand up to 40 MW m^{-2} for periods of 200 ms which corresponds to the time it takes the JET reciprocating probe drive to insert and withdraw the probe head from the JET plasma. The bulk temperature of the probe may transiently reach 500°C .
- The noisy electromagnetic environment of the tokamak sets the noise and limits the bandwidth of the electronics (currents down to a few nanoamps need to be measured) hence the need to optimise the device transmission.

The JET reciprocating probe drives are located on the top of the torus as shown in figure 3. Every two seconds the probe head can be driven into the plasma edge using a fast pneumatic

system giving a typical exposure time of 200 μs in the plasma. The drive system imposes important constraints on the probe head design:

- The external diameter of the probe must not exceed 40mm to be compatible with the JET probe drives. The size also needs to be kept down to minimize the voltage required since breakdown can be a problem in the plasma environment.
- The probe has to be aligned to within a few degrees with the local magnetic field. The most common magnetic field on axis (3.0 m major radius) is 2.5 T, so the field for the reciprocating PIMS probe head at a radius of 3.25 m will be typically 2.3 T (1/R scaling). For typical combinations of toroidal field and plasma current the field line is at an angle of 15° to the axis of the probe drive, see figure 3. Previous PIMS probes used in the DITE and TEXTOR tokamaks were simpler since the plasmas were circular and the drives mounted normal to the outer magnetic surface [3].
- The outer shell of the PIMS must be made of boron nitride so that the probe cannot be snapped off by halo currents in off-normal events and is resistant to thermal shock. Another major advantage of this material is that we can distinguish boron and nitrogen produced locally by interaction with the probe body from main plasma impurities.

4. JET-PIMS GEOMETRY

The dimensions of the active components of the JET PIMS are 4.35 × 8.5 × 18.5 mm. The focal length is 5.45 mm as compared to 9.5 mm used on DITE [2] and TEXTOR [3]. The ratios of the other dimensions to those in the earlier devices are similar. Due to the space restrictions the number of collectors has also been reduced to two. The entrance slit is 0.1 mm in width and made out of a single piece of TZM molybdenum alloy to maximize its power handling characteristics. Figure 4 shows the proposed engineering assembly of the PIMS head. Figure 5 shows the geometry of the PIMS as realised in the ion optics calculations including some trajectories calculated with the ion trajectory program SIMION6 [8] for realistic electric and magnetic fields.

Ions enter the PIMS through a small entrance slit in the plate perpendicular to the magnetic field and hence to the other plates in the device. This entrance slit is a symmetry point in the PIMS such that the potential of the plate that is level with the slit remains the same constant potential as the slit. The number of particles reaching the collector regions is a function of the ion temperature and the sheath voltage along with the electric field across the device.

The particle transmission is defined as the particle number reaching one of the two detectors in the PIMS divided by the total number of particles launched through the entrance slit. Originating

from the cyclotron focal length (b, eqn.†1) the so-called E-scale factor can be determined and is written as:

$$E_{\text{scale}} = E/E_{1\text{TH}} \quad (2)$$

where $E_{1\text{TH}}$ is the electric field required to focus hydrogen ions at a magnetic field of 1†T as predicted by equation (1) for the specific geometry under study. In the case of the JET PIMS geometry $E_{1\text{TH}} = 8.28 \times 10^4 \text{ Vm}^{-1}$. This normalisation makes it simple to see how close to the ideal performance we get.

For typical JET toroidal magnetic fields of $B_T = 2.5\text{T}$ on axis, B_T at the probe is 2.3T (1/Rscaling). Hence for main plasma gas which is usually deuterium, $m_i = 2$ and $z_i = 1$ so one needs $E = 2.2 \times 10^5 \text{ V/m}$. This translates into a voltage across the PIMS of around 957 Volts which is comparable to that used in the TEXTOR and DITE instruments. Higher voltages have been tried in these devices but were found to result in breakdown leading to a collapse of the electric field and spurious currents to the collectors during the plasma pulse.

The parallel velocity of the ions entering the PIMS is described by

$$v_{\parallel} = \sqrt{\frac{2}{m_i} \left(\frac{1}{2} m_i u_{\parallel}^2 + z_i e V_s \right)} \quad (3)$$

where v_{\parallel} is the parallel velocity, m_i and z_i the ion mass and charge, u_{\parallel} the ion velocity at the sheath edge and V_s the sheath voltage. The ion source is assumed to have a Maxwellian distribution which is borne out by retarding field analyser measurements [9]. The collector is divided into two so that some measure of the parallel distribution of the focussed ions is available. This is important to allow one to validate the measurements against the code predictions [2].

5. DESCRIPTION OF THE USED COMPUTER CODES

Simion 6 [8] as well as the similar custom written code in JET [2] compute the vacuum electric fields associated with a series of electrodes defined on a rectangular three dimensional grid through a numerical solution of Laplace's equation. Ions are randomly generated at the entrance slit with a Maxwellian distribution corresponding to a temperature T_i , and are accelerated parallel to the magnetic field to allow for acceleration in the plasma sheath (eqn.3). Ions are then followed through the structure until they impact with one of the surfaces or exit the grid.

There are two aspects to the modelling which are problematical. One is how to treat the barrier insulator (figure 5), whose purpose is to prevent ions reaching the collector which have not passed through the defining slit. We have either assumed that it does not perturb the local field at all or set it at ground potential which is the worst case assumption used in the results presented here. The second issue is that of space charge which may affect the ion optics in the region

between the entrance slit and defining slit. This is beyond the capability of the codes available to us to deal with and so is left for future study.

Comparison of the two codes for specific cases has shown that the results are identical so we do not distinguish between them in discussing the results.

6. SUMMARY OF ISSUES TO ADDRESSED

The most important issue to be calculated in the ion optics simulations is the transmission of the different charge states of ions we expect to see in the edge of JET. It is clear that the PIMS is expected firstly to detect and distinguish deuterium and carbon ions of different charge stages plus smaller amounts of beryllium. Simulations were carried out to confirm that the geometry of the PIMS chosen has transmission characteristics that are not too sensitive to sheath voltage and ion temperature, and that magnetic field misalignment do not significantly degrade the resolution.

Figure 6 shows the anticipated ion temperature and electron temperature profiles in the type of JET discharge in which the PIMS will be most frequently used. These numbers are computed by the EDGE2D-U/NIMBUS code which is a multi-fluid edge plasma simulation code linked to a Monte-Carlo hydrogen neutral model [10] which has been used to fit actual diagnostic data. Figure 7 shows the predicted densities for the various charge states of carbon. If you compare the prediction of figure 7 with the mass-spectrum of figure 1, and bear in mind that the detected current is proportional to the ion density times the charge on the ion, you will see that we expect JET to have many more high charge state ions in the edge plasma than DITE. This can be understood in terms of the higher temperature and confinement time of the JET plasma relative to DITE.

7. RESULTS

Our base case assumes an ion temperature $T_i = 50\text{eV}$ and sheath voltage, $V_s = 100\text{V}$ (from sheath theory $V_s \approx 3T_e$). Figure 8 shows the maximum transmission versus charge state for the base case where the transmission is the current at the collectors divided by the current entering the device. All the results presented here are for the most common toroidal magnetic field at the probe of 2.3T. One can see from figure 8 that the ions with high M/Z are mainly deposited on collector 2 whilst those with low M/Z go to collector 1. This is because the ions reach the collector from the defining slit in one gyro-period and during this time travel parallel to the magnetic field, see figure 5. Although a single ratio of the two collector currents would not allow one to distinguish the sheath voltage from the ion temperature, by using the current ratios for ions with a range of M/Z the problem becomes soluble [2].

Since the PIMS has perfect focusing properties we expect the rectangular image of the defining slit to be projected onto the rectangular collectors and move across linearly with the applied

electric field (eqn. 1). This results in triangular peaks (see figure 9). The theoretical resolution to totally separate two triangular peaks of different M/Z for the PIMS as derived from the analytical formula (eqn. 1) is:

$$R_{th} = \text{distance between defining slit and collectors} / (\text{defining slit width} + \text{collector width}) = 7.25$$

To totally resolve peaks due to C^{5+} and C^{6+} (or D^+) we need a resolution of 5. In practice we can resolve peaks that overlap [3] so the practical resolution is about double the value quoted. So our basic requirement to resolve the most common carbon ions can be met with a resolution well below the theoretical limit.

The resolution obtained from our base case simulation for C^{3+} ions is given by:

$$R_{exp} = E\text{-scale at which peak max. occurs} / \text{peak full width} = 7.65$$

This is slightly better than our simple analytical model would suggest due to the fact that the ions pass through the slits at an angle and so the effective slit width is reduced which more than offsets any broadening due to non-uniformities in the computed electric field.

7.1 Mis-alignment with the magnetic field

The effects of small field misalignments will be a crucial point in operating the PIMS in JET. This is due to the fact that although the toroidal magnetic field is well known the poloidal magnetic field is not so well known due to uncertainties in the radial profile of the plasma current. The total magnetic field in JET is helical with typical pitch of 15° . In this situation the electric and magnetic fields inside the PIMS may no longer be orthogonal to each other. Misalignments of $\pm 3^\circ$ about both axes are considered a worst case and have been investigated.

For a mis-alignment lying in same plane as E-field plates (x direction), the maximum transmission obtainable was slightly lower than for the situation where the fields were totally aligned and the resolution was slightly degraded but not by enough to cause concern, figure 9.

Mis-alignments of the magnetic field normal to the electric field plates were also studied and the results for C^{3+} (which are typical of other charge states) are shown in figure 10. This shows a less symmetric behaviour with a stronger distortion of the peaks.

7.2. Effect of ion temperature and sheath potential on transmission

Since we will be making measurements under conditions of variable ion temperature and sheath voltage it is important to ensure that the total transmission (collectors 1+2) is not too strongly dependent on the edge ion temperature and sheath voltage. Scans have therefore been done in

these parameters for all charge states. In the case of the ion temperature scan the sheath voltage was fixed at 100V, figure 11. This shows that there is a decrease in transmission with ion temperature which is strongest for the lower charge states. The transmission for C^+ ions is essentially zero at this sheath voltage for all ion temperatures whilst the C^{2+} transmission decreases strongly with increasing ion temperature.

The scan of sheath voltage at a fixed ion temperature of 50eV is shown in figure 12. Transmission of C^+ and C^{2+} improves at low sheath voltage. The poor transmission of the low charge states is due to the fact that ions travel from the defining slit to the collector in a time equal to the gyro-period. Combination equation (3) for the parallel velocity with the ion gyro period $\tau_i = \frac{2\pi m_i}{z_i e B}$ gives the parallel distance travelled between leaving the defining slit and entering the collector:

$$s = \frac{2\pi m_i}{z_i e B} \sqrt{(u_{\parallel}^2 + \frac{2z_i e V_s}{m_i})} \quad (4)$$

where T_i is the ion temperature in eV and V_s the plasma sheath voltage. When this distance exceeds the maximum parallel dimensions of the device then transmission declines rapidly.

6. DISCUSSION AND FUTURE WORK

The ideal PIMS design would have transmission characteristics for all charge states which are independent of plasma conditions. This is not achievable for the low charge states but we expect most of the ions in the edge of JET to be in high charge states C^{3+} to C^{6+} . The transmission for these is more robust against plasma variations which means that the concentrations of light impurity ions should be determined with sufficient accuracy. To observe the concentrations of the low charge states we will have to operate in plasmas with low electron temperatures and hence low sheath voltage or we can shift the potential in the region where the ions enter the stack of E-field plates so that the ions are retarded. This situation has not yet been analysed in our simulations and will be one focus for future work.

Another factor which will improve the transmission of low charge states is that C^+ and C^{2+} are expected to be significantly colder than the higher ionisation states [2]. This is due to the fact that ionisation time will be shorter than the thermalisation time. Although the multi-fluid edge plasma code EDGE2D-U/NIMBUS models each charge state as an independent fluid, it assumes that each charge state is thermalised with the background deuterium plasma. To compute the individual temperatures we will need to run Monte-Carlo impurity transport code (trace approximation) on a fixed plasma background and extract the ion temperature information for each charge state.

7. CONCLUSIONS

The edge of a magnetic fusion device is a severe and demanding environment for deploying a mass-spectrometer, particularly one whose purpose is to sample a high temperature plasma. Previous experience on small tokamaks has however shown the feasibility and utility of such devices. However, as the largest tokamak in the world, the JET environment and probe drive systems place even more severe demands on the design, including the need to shrink the device dimensions by 43% to give a focal length of 5.45mm and fit within an overall diameter of 40mm. Our simulations of the ion optics of the proposed device have however shown that we expect good transmission of the high charge state ions which are predicted to be the most abundant and hence of greatest interest to us. It is clear that ion optics simulations will be essential to the interpretation of any results obtained from the device. Also, due to the importance of the local ion temperature and sheath voltage, these results will have to be interpreted in close conjunction with plasma simulation codes to provide a consistent overall picture. The issue of mis-alignment with the JET total magnetic field has been shown to be tolerable within the expected uncertainties.

Future work will concentrate on developing biasing schemes and minor geometric variations to optimise the transmission of the lower charge states ions.

ACKNOWLEDGEMENTS

Work was carried out under the European Fusion Development Agreement as an EFDA-JET enhancement project and was partly funded by EURATOM and the UK Department of Trade and Industry as well as the FWF, Vienna, Austria.

REFERENCES

- [1] G.F.Matthews, Plasma Physics and Contr. Fusion, Vol. 31, No. 5 (1989) 853
- [2] G.F.Matthews, J. Nucl. Mater. 176&177(1990)1032
- [3] G.F.Matthews, D.Elder, G.M.McCracken et al., J. Nucl. Mater. 196-198 (1992) 253-257
- [4] ITER physics basis editors, et al., Nuclear Fusion Vol. 39, No.12 (1999) 2137-2664
- [5] Bleakney W. and Hipple J. A.,(1938) Phys. Rev. 53, 521-529
- [6] N. Krall and Trivelpiece, Principles of Plasma Physics (San Francisco Press, San Francisco, 1986)
- [7] G.F.Matthews, Plasma Phys. Cont. Fusion 36 (1994) 1595
- [8] Simion 3D Version 6.0, User's Manual, David.A.Dahl, 1995, Princeton Electronic Systems, Inc.
- [9] R.A.Pitts and G.F.Matthews, J. Nucl. Mater. 176-177(1990) 877
- [10] R.Simonini et al., Contrib. Plasma Phys. 34(1994) 368

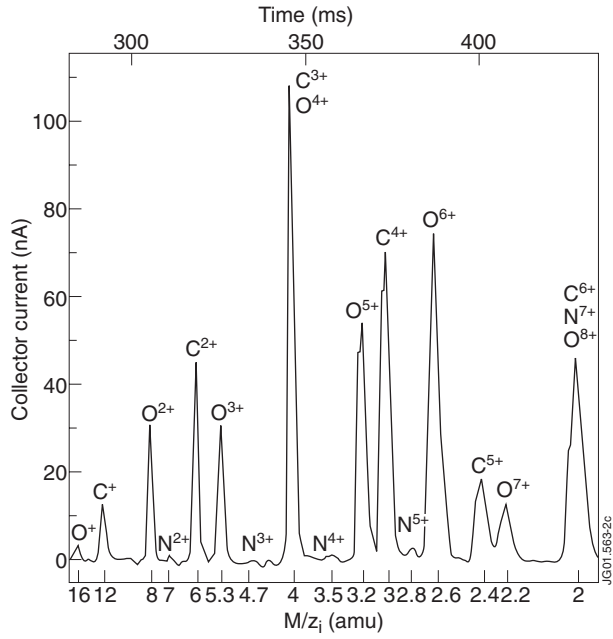

Figure 1: Mass-spectrum from a plasma ion mass-spectrometer (PIMS) in the edge plasma of the DITE tokamak [2]. M is the atomic mass of the ion and z_i its charge state. The electric field in the PIMS ramped up linearly with time, top axis, to sweep the various ion species across the collector during steady state phase of the plasma discharge.

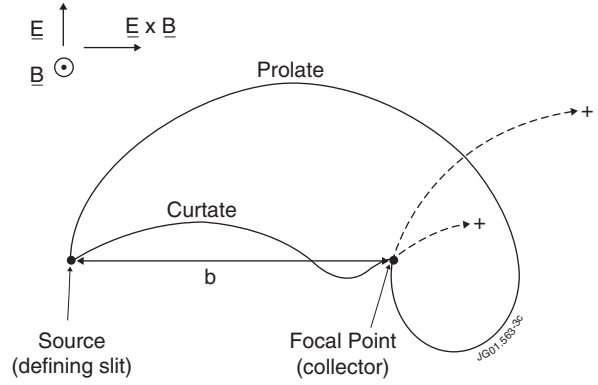

Figure 2: In perpendicular electric and magnetic fields ion orbits are cycloidal and the focussing properties are perfect [5].

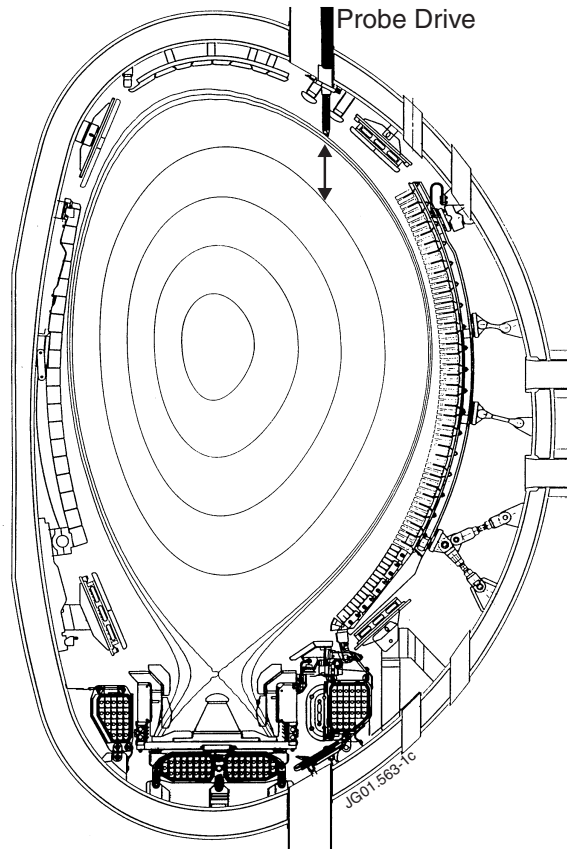

Figure 3: Cross-section of the JET torus and plasma showing the location of the reciprocating probe head.

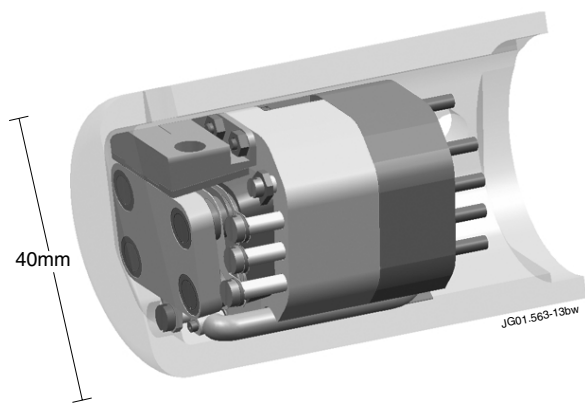

Figure 4: Engineering and assembly of the PIMS probe head.

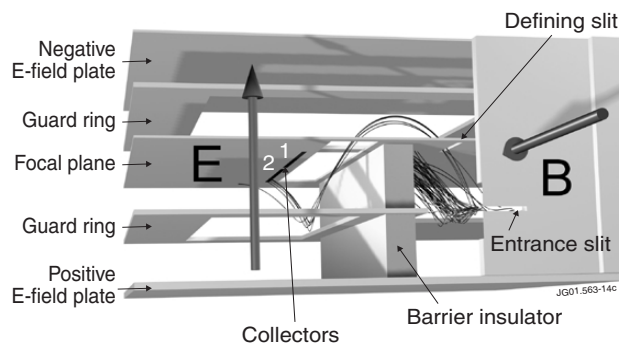

Figure 5: Geometry of the PIMS probe as realised in the ion optical calculations.

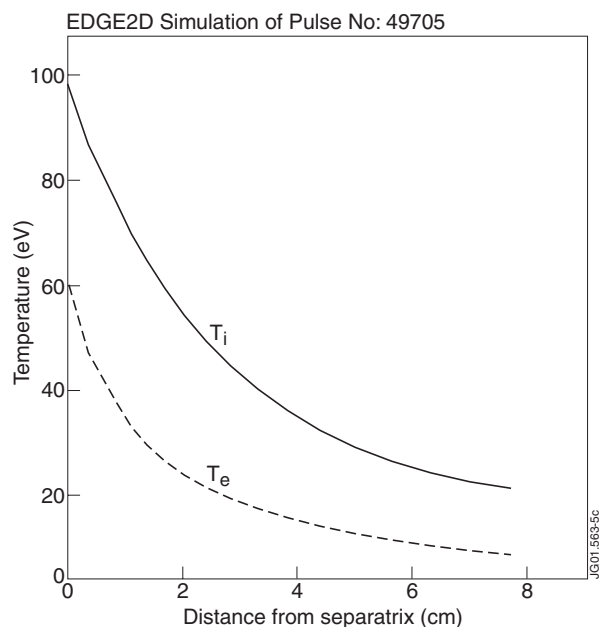

Figure 6: Ion temperature and electron temperature as predicted by EDGE2D-U/NIMBUS for pulse 49705 which is an L-mode plasma with 2.5MA of plasma current, 2.5T toroidal field and 2MW of neutral beam heating.

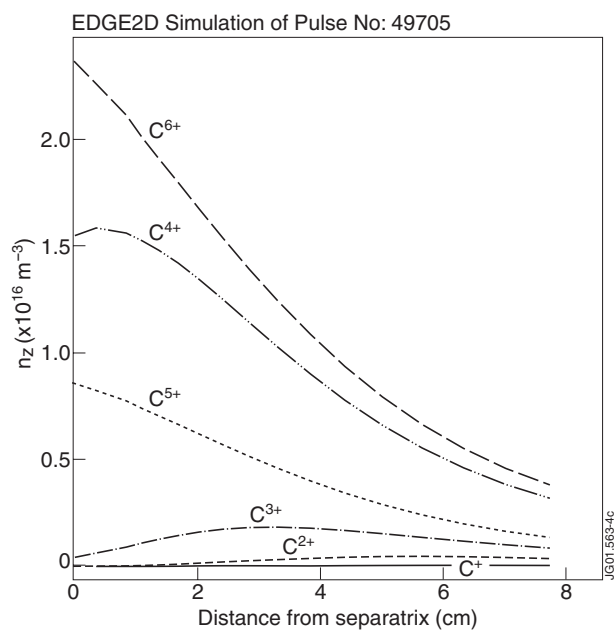

Figure 7: Charge state distribution predicted by EDGE2D-U/NIMBUS for JET pulse 49705.

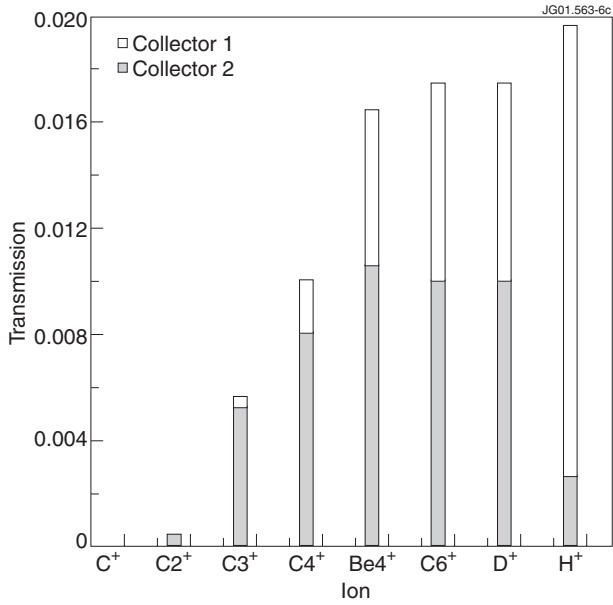

Figure 8: Peak transmission for different charge states of carbon for the base case.

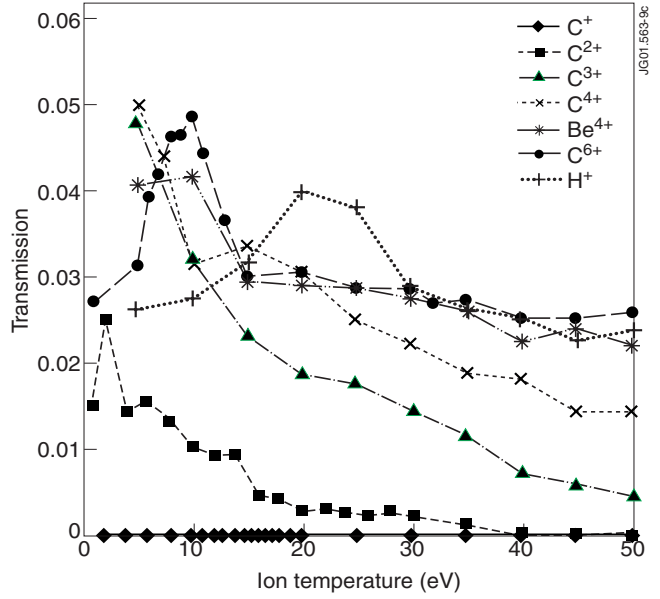

Figure 9: Simulated C³⁺ peak profiles for aligned and mis-aligned magnetic field $\pm 3^\circ$ in the plane of the electric field plates (x direction).

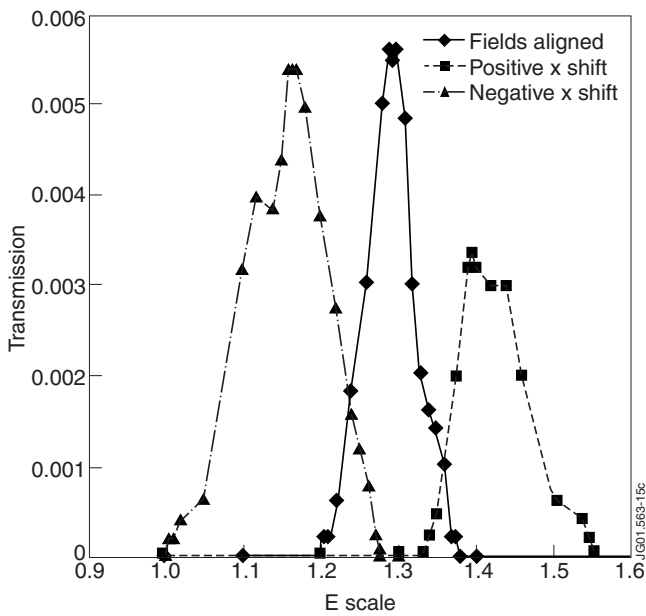

Figure 10. Simulated C³⁺ peak profiles for aligned and mis-aligned magnetic field $\pm 3^\circ$ out of the plane of the electric field plates (y direction).

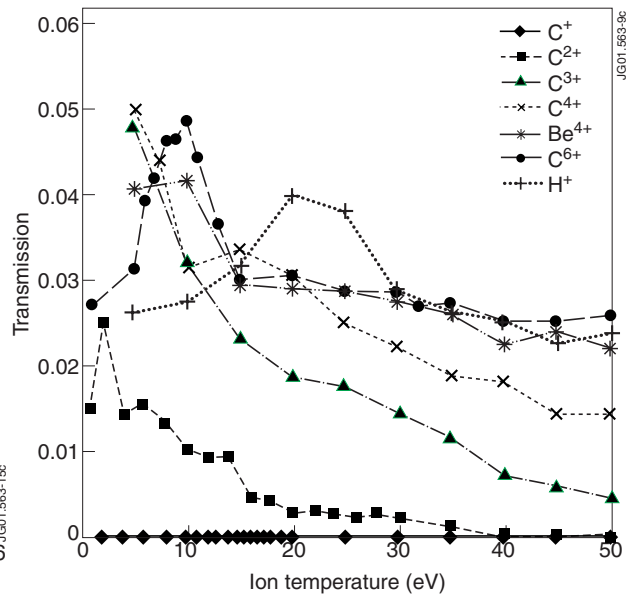

Figure 11. Variation of total transmission with ion temperature for a fixed sheath voltage of 100V.

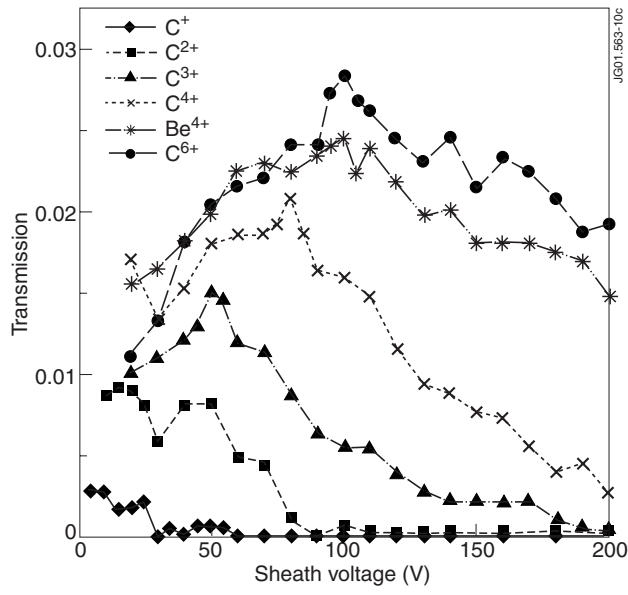

Figure 12. - Variation of total transmission with sheath voltage for an ion temperature of 50eV.