

U. Kruezi, H.R. Koslowski, S. Jachmich, M. Lehnen, S. Brezinsek,
G. Matthews and JET EFDA contributors

A New Disruption Mitigation System for Deuterium – Tritium Operation at JET

“This document is intended for publication in the open literature. It is made available on the understanding that it may not be further circulated and extracts or references may not be published prior to publication of the original when applicable, or without the consent of the Publications Officer, EFDA, Culham Science Centre, Abingdon, Oxon, OX14 3DB, UK.”

“Enquiries about Copyright and reproduction should be addressed to the Publications Officer, EFDA, Culham Science Centre, Abingdon, Oxon, OX14 3DB, UK.”

The contents of this preprint and all other JET EFDA Preprints and Conference Papers are available to view online free at www.iop.org/Jet. This site has full search facilities and e-mail alert options. The diagrams contained within the PDFs on this site are hyperlinked from the year 1996 onwards.

A New Disruption Mitigation System for Deuterium – Tritium Operation at JET

U. Kruezi¹, H.R. Koslowski², S. Jachmich³, M. Lehnen⁴, S. Brezinsek²,
G. Matthews¹ and JET EFDA contributors*

JET-EFDA, Culham Science Centre, OX14 3DB, Abingdon, UK

¹*CCFE, Culham Science Centre, Abingdon, Oxon, OX14 3DB, United Kingdom*

²*Forschungszentrum Jülich GmbH, IEK-4, 52425 Jülich, Germany*

³*Laboratory for Plasma Physics, ERM/KMS, B-1000 Brussels, Belgium*

⁴*ITER Organization, Route de Vinon –sur-Verdon,*

CS90046 - 13067 St Paul Lez Durance Cedex, France

** See annex of F. Romanelli et al, “Overview of JET Results”,
(24th IAEA Fusion Energy Conference, San Diego, USA (2012)).*

ABSTRACT

Disruptions, the fast accidental losses of the plasma current and stored energy in tokamaks, represent a significant risk to the mechanical structure as well as the plasma facing components of reactor-scale fusion facilities like ITER. At JET, the tokamak experiment closest to ITER in terms of operating parameters and size, massive gas injection has been established as a disruption mitigation method. As a “last resort” measure it reduces thermal and electromagnetic loads during disruptions which can potentially have a serious impact on the beryllium and tungsten plasma-facing materials of the main chamber and divertor. For the planned deuterium-tritium experiments, a new Disruption Mitigation System (DMS) has been designed and installed and is presented in this article. The new DMS at JET consists of an all metal gate valve compatible with gas injections, a fast high pressure eddy current driven valve, a high voltage power supply and a gas handling system providing six supply lines for pure and mixed noble and flammable gases (Ar, Ne, Kr, D₂ etc.). The valve throughput varies with the injection pressure and gas type (efficiency 50–97%); the maximum injected amount of gas is approximately 4.6kPa·m³ (at maximum system pressure of 5.0MPa).

1. INTRODUCTION

Disruptions, the fast accidental losses of the plasma current and stored energy in tokamaks, are critical issues for reactor-scale fusion facilities like ITER and present a risk of severe damage to vital plant components and structures. Although the rate of disruptions can be successively minimized by developing appropriate techniques to operate tokamaks, they may never be completely avoidable [1,2]. This has led to an international effort to study mitigation techniques such as Massive Gas Injection (MGI) [3–6].

Disruption mitigation is crucial, especially in larger tokamaks like JET with its ITER-like Wall (ILW - Be and W used as plasma-facing material in the main chamber and divertor) [7] which can experience considerable damage during unmitigated disruptions. The absence of radiating impurities due to the ILW can have severe implications such as excessively high heat loads on the Plasma Facing Components (PFC), leading to melting events, as well as high forces on the vacuum vessel and the supporting structure. To minimise these effects a MGI valve and corresponding auxiliary equipment, originally design for MGI studies, has been integrated into the JET machine protection system [8,9]. With the utilisation of this valve the first Disruption Mitigation System (DMS) was established at JET which could reduce high vessel forces and local heat loads on PFCs by increasing the radiated energy up to 100% of the initially stored energy [10]. Plasma operation without DMS has been generally restricted to plasma currents up to 2MA and total plasma energy (poloidal magnetic + kinetic) below 5MJ. As a consequence, the majority of JET pulses nowadays require the DMS; the requirements for the reliability and the availability of the existing system resulted into the need for a new DMS. This new system includes a new MGI valve and corresponding auxiliary systems which have been designed and integrated into the JET environment, primarily to provide redundancy to the original DMS during deuterium-deuterium operation. Furthermore it allows a wider range of MGI experiments due to significant performance improvement compared to the original system. It

incorporates experimental features such as six separate gas feeding lines, for example Ar, Ne, Kr, D₂, N₂ and mixtures of these, similar to the original DMS (three lines), but is also able to deliver five times more gas in two thirds of the time due to a shorter and wider gas delivery tube. The new DMS has been specifically designed to operate reliably under harsh nuclear conditions and to act as a reliable machine protection system during the planned deuterium-tritium (DT) campaign at JET. This article presents the new DMS at JET, which consists of a fast high pressure eddy current driven valve, the Disruption Mitigation Valve (DMV), an all metal gate valve compatible with high pressure injections, a high voltage power supply and an all metal gas handling system providing six separate supply lines for flammable and noble gases.

2. THE DISRUPTION MITIGATION SYSTEMS AT JET

The two disruption mitigation systems at JET consist of two fast eddy current driven valves called DMV1 and the new DMV2 located in two different JET octants (toroidally 90° apart) and poloidal positions, as indicated in figure 1a. DMV1 is mounted on a probe drive on top of JET in octant 1 and is connected via a 4.1m long gas delivery tube to the vacuum vessel (diameter 40mm, distance to separatrix ~0.5m). DMV1 and the attached delivery tube can be driven through a gate valve with the help of the probe drive infrastructure and can be retracted if necessary to seal off the primary Torus vacuum. The new valve (DMV2), shown in figure 1b, is located in octant 3 on a horizontal port with a wider and shorter gas guiding tube (length 2.4m, diameter 150mm, distance to separatrix ~0.6m). For reliability purposes, no moving parts are present within the primary Torus vacuum in the new system, fulfilling containment requirements for DT operation. The injected gas passes a special type of gate valve which is designed to withstand higher pressures and to optimized the through flow. In general, the simplification of the setup is one of the key features to assure a reliable DMS operation. Both valves are activated by individual HV power supplies. These power supplies are triggered by the JET Pulse Termination Network (PTN) utilizing a direct fiber connection [9] leading to the desired gas release. A typical MGI sequence applying DMV2 is shown in figure 1c. In closed loop operation, once the potential for a disruption arises (typically when the amplitude of a locked $n = 1$ mode or an excursion of the loop voltage, indicating the start of the CQ, is detected) or is deliberately induced for disruption studies, a trigger signal is generated, warning first all auxiliary heating and diagnostic systems of potential damage from high vacuum pressures. When these systems are in a safe state, the trigger is passed to the DMS high voltage power supply which induces a current into the DMV coil causing the valve to open and to inject the gas into the plasma (within 5 ms). As a result, the radiation increases due to the interaction between the injected gas and the plasma, which effectively reduces the plasma energy. Ideally this is achieved before the plasma becomes vertically unstable and hits the wall causing excessive heat loads on the PFCs. The gas for either machine protection or MGI experiments is provided by individual Gas Handling Systems (GHS). Both of these are equipped with the possibility to load pure gases or gas mixtures and to remove or change these gases automatically in between plasma pulses upon request of the main JET

control system. As a pressurized high voltage system, the DMS has to provide operational safety aspects as well as personnel safety. It is therefore equipped with various passive mechanical safety features, software and hardware interlocks and monitoring equipment managed by an industrial control system described elsewhere [11].

2.1. DISRUPTION MITIGATION VALVE

The new disruption mitigation valve is shown in figure 1b. It consists of two volumes, the injection volume and the spring volume. Both volumes are connected by a “mushroom” shaped piston and are sealed against each other with the help of two radial (dynamic) seals surrounding the piston cylinder. The latter carries a small plate with an integrated third (static) seal and is pressed by disc springs located inside the spring volume against the bottom of the injection volume sealing the orifice. The spring force is optimized to seal the injection volume towards the torus vacuum (leak rate 10^{-6} Pa·m³/s) before the valve is actuated and to restore the sealed condition upon actuation. To optimize the injected gas quantity, the spring volume is evacuated. The process to inject the gas stored in the injection volume is initiated by discharging the capacitor bank of the associated high voltage power supply through the external coil of the DMV. As a result, a time-varying magnetic field excites eddy currents in the “mushroom” surface of the piston body and the resulting JxB force repels and lifts the piston. The stainless steel body of the DMV is sealed with metal seals to atmosphere and is bolted together minimizing welding. An assessment of the material properties of the polymer seals has shown that no significant damage should be expected at the fast neutron fluxes during the DT operation. The valve body has been pressure tested up to 8.0MPa which restricts the operation pressure to 5.0MPa. With a volume of $9.75 \cdot 10^{-4}$ m³ and an orifice of 30mm, it is in principle capable of injecting gas up to 4.875kPa m³. This new DMV, is a result of significant development of eddy current driven disruption mitigation valves by Forschungszentrum Jülich over the last decade. DMV1 (2005) was one of the first generations and DMV2 has a far more advanced design. The latest development is a full metal DMV prototype which incorporates only ITER compatible materials. This valve is described elsewhere [12].

2.2. GATE VALVE FOR HIGH PRESSURE INJECTIONS

For maintenance purposes the DMV is not directly connected to the primary JET vacuum vessel, but is connected to an all metal gate valve. In figure 2a the issues with gate valves and high pressure injections are illustrated. Injecting through a normal gate valve will not only increase the pressure in the gate valve body, which might damage the valve, but also will strongly influence the gas flow. The special JET DMS version shown in figure 2b and 2c is equipped with two features to overcome this issue. The first feature is a gas guiding ring which is placed in the open state of the gate valve into a position minimizing the gap in the valve body enabling high pressure injections with a minimum disturbance of the gas flow. The second feature has been designed to minimize the risk of damage to the gate valve itself by including a vented protection cap for the most fragile

part of the gate valve, the internal bellows. Furthermore this gate valve is designed to withstand pressures of up to 0.6MPa in case the DMV injects into a closed volume, as a worst case scenario. This is sufficient to prevent damage to the valve body in the present setup.

2.3. HIGH VOLTAGE POWER SUPPLY

The High Voltage Power Supply (HVPSU) is equipped with a capacitor bank of 400 μ F and a HV transformer charging the capacitor up to 2kV (typically 1.8kV). Upon receipt of the trigger, which is transmitted via an optical fiber, a high voltage thyristor is activated causing the capacitors to discharge into the DMV coil. The typical timescales of this fast discharge are a few ms. For monitoring purposes, all relevant signals (voltage, current etc.) and commands (charge, discharge etc.) are transferred to the DMS control system. All inputs and outputs are isolated to minimize the risk of high frequency noise entering and disturbing the internal control electronics. To optimize the DMV throughput the HVPSU is located near the DMV to minimize the coaxial cable length and therefore conserve the required short current pulse. For DT operation the HVPSU will be placed behind the biological shield connected to the DMV coil via a longer (approximately 25m) cable.

2.4. GAS HANDLING SYSTEM

One of the key features of the DMS is the Gas Handling System (GHS) shown in figure 3. It fulfills multiple purposes: 1. It provides different gases, generates mixtures and charges the DMV with gas for the MGI. It is also equipped with pumping capabilities to evacuate the spring volume, injection volume and gas supply lines to avoid contamination between gases in case gases are changed or mixed. 2. A combination of vacuum and pressure gauges enable the monitoring and recording of important process parameters such as vacuum pressure, inlet pressure, exhaust pressure and injection pressure. The measurement of the injection pressure is used to assess the injected gas quantity which to monitor the flammable gas limits of the cryogenic pump inventory. These process parameters can also be utilized to assess the condition of the radial seals as well as the condition of the gas guiding ring. An increased leak into the respective volumes would indicate a degradation of these essential DMS components. Continuous recording enables long term diagnosis. 3. The GHS consists exclusively of high pressure compatible components in order to be inherently safe for plant and personnel. Additional safety is achieved by implemented pressure relief valves with nitrogen venting capabilities in case a flammable gas overpressure event occurs (see more details in [11]). 4. In the unlikely event that single or all pressure gauge information is lost due to damages by fast neutrons, the GHS incorporates a combination of electro-mechanical pressure switches, a burst disk and a pressure relief valve to keep the GHS operational for machine protection purposes. Although the present state of the GHS includes strain detector pressure gauges with integrated electronics, a new type of radiation hard gauge has been successfully tested without internal

3. FIRST APPLICATIONS AND EXPERIENCE

The DMS was brought into operation in 2014 and has been tested at various pressures and gas

mixtures. In figure 4, the injected quantity of gas is shown as well as the efficiency (Pressure drop/charging pressure). Although these measurements indicate that for light gases or mixtures there is a linear relation between the charging pressure and the delivered gas quantity at a efficiency above 90%. This does not appear to be the case for heavier gases (such as N₂, Ar or Kr). Here, the efficiency appears initially to drop, to level off and rise at higher pressures reaching 90% efficiency at 5.0MPa in case of N₂ (from a minimum efficiency of 70% at around 2.0MPa). This behavior is not quite understood and is most likely caused by a gas dynamic effect. Further investigations are necessary to clarify this issue. However, this effect does not restrict the DMV2 applications and does not have any effect on the use for machine protection purposes. For the latter a mixture of 10% Ar and 90% D₂ at 1.0 kPa·m³ is currently utilized. General restrictions apply to the total amount of injected gas during normal JET operation due to potentially overloading the JET cryogenic pump. To avoid a high heat transfer through the injected gas onto the cryogenics system operational pressures are reduced depending on the gas type (e.g. for 10%Ar + 90%D₂ 2.6 kPa m³). Due to recent reliability issues of DMV1, DMV2 has started to provide permanent machine protection for more then two months in 2014 with 223 gas injections reliably applied in closed loop operation. In addition various MGI experiments covering disruption mitigation as well as runaway electron studies were successfully utilizing the new DMS in combination with the existing system [13].

ACKNOWLEDGMENTS

This work was supported by EURATOM and carried out within the framework of the European Fusion Development Agreement. The views and opinions expressed herein do not necessarily reflect those of the European Commission or the ITER Organization.

REFERENCES

- [1]. T.C. Hender et al., 2007 Nuclear Fusion **47** S128
- [2]. P.C. de Vries et al., 2009 Nuclear Fusion **49** 055011
- [3]. D.G. Whyte et al., 2002 Physical Review Letters **89** 055001
- [4]. R.S. Granetz et al. 2007 Nuclear Fusion **47** 1086
- [5]. G. Pautasso et al., 2007 Nuclear Fusion **47** 900
- [6]. M. Lehnen et al., 2011 Nuclear Fusion **51** 123010
- [7]. G. Matthews et al., 2013 Journal of Nuclear Materials **438** S1-S10
- [8]. U. Kruezi et al., 36th EPS Conference on Plasma Physics Sofia, June 29 – July 3, ECA 33E, P-2.153 (2009).
- [9]. C. Reux et al., 2013 Fusion Engineering and Design **88** 1101– 1104
- [10]. M. Lehnen et al., 2013 Journal of Nuclear Materials **438** S102-S107
- [11]. S. Jachmich et al., this conference
- [12]. G. Czymek et al., this conference
- [13]. C. Reux et al., 25th IAEA Fusion Energy Conference, St Petersburg, Russia

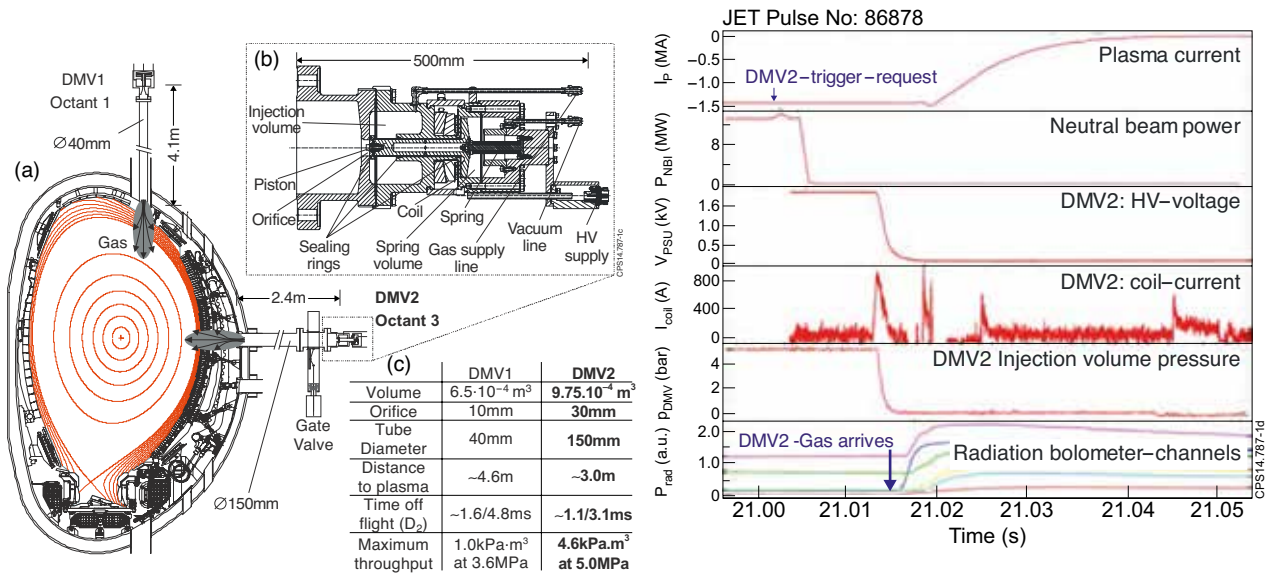

Figure 1: (a) Poloidal cut of JET presenting the JET DMS. The two Disruption Mitigation Valves (DMV) are projected into the same poloidal plane. Their physical positions are on top of the machine in octant 1 (DMV1) and at a horizontal position in octant 3 (DMV2). Both systems are located 90° toroidally apart. (b) Technical drawing of the new DMV (DMV2). (c) Characteristic properties of the two DMS. (d) Typical DMV2 sequence (JET Pulse Number: 86878, $B_t = 1.5 \text{ T}$, $I_p = 1.5\text{MA}$, Auxiliary heating: 14MW NBI, DMV request time: 21.0s, Total injected gas: 0.5-kPa m^3 of 10% argon and 90% deuterium mixture, Time of flight: $\sim 1.5\text{ms}$, Total radiated energy fraction is about 92% (not considering radiation asymmetry effects)).

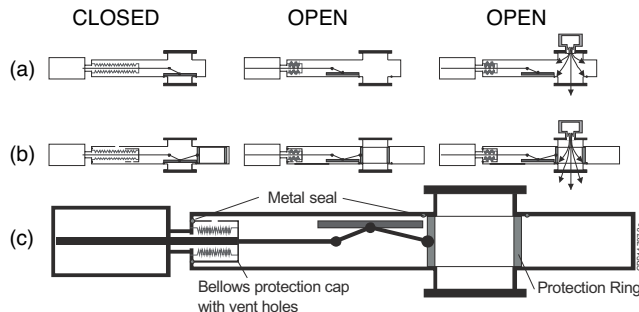

Figure 2: Illustration of the all metal gate valve compatible with high pressure injections. (a) Normal gate valve and (b) special gate valve in closed-open state and in the case of a gas injection through the open gate valve. (c) Special gate valve key design features.

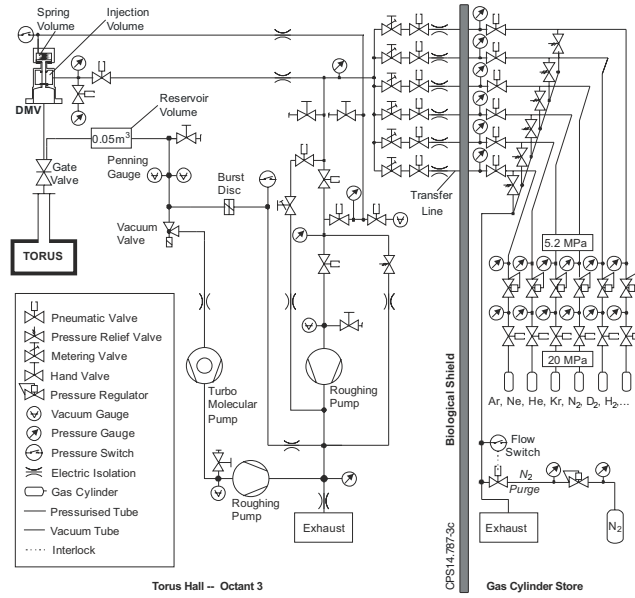

Figure 3: Schematic of the new DMS Gas Handling System.

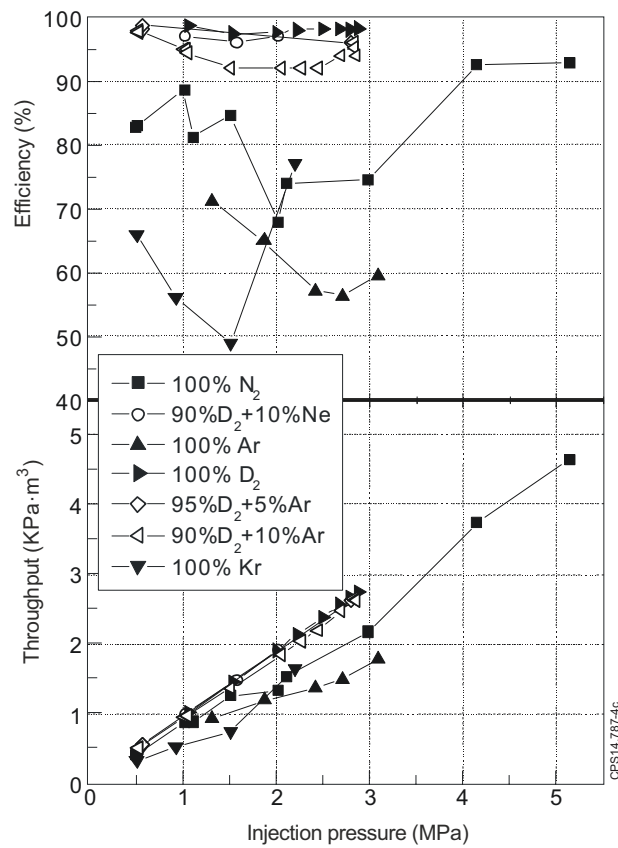

Figure 4: Valve throughput and efficiency (Pressure drop/charging pressure) for DMV2 at various injection volume pressures.

