

J. Beal, A. Widdowson, K. Heinola, A. Baron-Wiechec, K.J. Gibson,
J.P. Coad, E. Alves, B. Lipschultz, A. Kirschner, G.F. Matthews,
S. Brezinsek and JET EFDA contributors

Analysis of Rotating Collectors from the Private Region of JET with Carbon Wall and Metallic ITER-Like Wall

“This document is intended for publication in the open literature. It is made available on the understanding that it may not be further circulated and extracts or references may not be published prior to publication of the original when applicable, or without the consent of the Publications Officer, EFDA, Culham Science Centre, Abingdon, Oxon, OX14 3DB, UK.”

“Enquiries about Copyright and reproduction should be addressed to the Publications Officer, EFDA, Culham Science Centre, Abingdon, Oxon, OX14 3DB, UK.”

The contents of this preprint and all other JET EFDA Preprints and Conference Papers are available to view online free at www.iop.org/Jet. This site has full search facilities and e-mail alert options. The diagrams contained within the PDFs on this site are hyperlinked from the year 1996 onwards.

Analysis of Rotating Collectors from the Private Region of JET with Carbon Wall and Metallic ITER-Like Wall

J. Beal^{1,2}, A. Widdowson², K. Heinola^{1,3}, A. Baron-Wiechec², K.J. Gibson¹,
J.P. Coad⁴, E. Alves⁵, B. Lipschultz¹, A. Kirschner⁶, G.F. Matthews²,
S. Brezinsek⁶ and JET EFDA contributors*

JET-EFDA, Culham Science Centre, OX14 3DB, Abingdon, UK

¹*York Plasma Institute, Department of Physics, University of York, Heslington, York, YO10 5DD, UK.*

²*Culham Centre for Fusion Energy, Abingdon, OX14 3DB, UK.*

³*University of Helsinki, PO Box 43, 00014 University of Helsinki, Finland.*

⁴*VTT Technical Research Centre of Finland, PO Box 1000, 02044 VTT, Espoo, Finland.*

⁵*Instituto de Plasmas e Fusão Nuclear, Instituto Superior Técnico, Universidade de Lisboa,
Avenue Rovisco Pais, 1049-001, Lisboa, Portugal.*

⁶*Forschungszentrum Jülich, Institut für Energie- und Klimaforschung Plasmaphysik,
52425 Jülich, Germany.*

** See annex of F. Romanelli et al, "Overview of JET Results",
(24th IAEA Fusion Energy Conference, San Diego, USA (2012)).*

Preprint of Paper to be submitted for publication in Proceedings of the
21st International Conference on Plasma Surface Interactions, Kanazawa, Japan
26th May 2014 – 30th May 2014

ABSTRACT

Rotating collectors are used in JET to provide time-resolved measurements of erosion and redeposition of vessel materials. The silicon collecting disks rotate behind an aperture, driven by pulsing of the toroidal magnetic field, with the deposits analysed ex-situ by Nuclear Reaction Analysis. The angular dependence of deposition is mapped to discharge number using the B-field history, allowing the influence of different plasma configurations and parameters to be investigated. A simple geometrical model using sputtering and reflection from the strike point has qualitatively reproduced the deposition found on collectors located under the central divertor tile and facing towards the inner strike point. The beryllium deposition on the ITER-like wall (ILW) collector showed an order of magnitude reduction in deposition compared to carbon deposition on the JET-C collector. This decreased deposition is attributed to low long range divertor transport due to reduced chemical sputtering/erosion and codeposition of beryllium relative to carbon.

1. INTRODUCTION

Erosion, deposition and material migration are of critical importance both for the lifetime of tokamak first wall components and for their impact on plasma behaviour. The nature and degree of physical, chemical and thermal plasma-material interactions are strongly dependent on the material composition of the plasma-facing surfaces. In 2010, the carbon wall of JET-C was replaced with beryllium main chamber and tungsten divertor. This ITER-like wall (ILW) [1] has provided the first complete test of the plasma-facing material combination proposed for ITER. The exchange caused an almost complete replacement of carbon in the plasma by beryllium [2]. Thus, we assume here only carbon impurities in the carbon case and beryllium impurities in the ILW case.

Since detailed material analysis of plasma-facing components is generally only practical ex-situ, data on the evolution of surfaces typically has the time resolution of a 1-2 year operating campaign. By varying the surface exposed to the plasma, rotating collectors offer an improved time resolution and thereby enable an investigation of the effects of changing plasma conditions. This contribution focuses on deposition measurements from rotating collectors in the private-flux region of the JET divertor during 2005-12, and analyses it in terms of plasma conditions and first wall composition.

2. EXPERIMENTAL

Since a detailed explanation of rotating collectors is offered in [3], only a brief description is provided here. Each collector comprises a silicon disk that acts as a substrate for deposition, incrementally rotated via a geared drive by the pulsing of the toroidal magnetic field. A slit in the collector housing exposes a 2mm toroidal strip on the circumference of the disk at any given time. This corresponds to ~ 55 times the circumferential distance rotated each JET discharge, giving a moving sum of deposition. The angular deposits are mapped to discharge number, neglecting those with insufficient magnetic field to drive rotation.

Between campaigns, the collectors are retrieved and analysed ex-situ by nuclear reaction analysis (NRA). An incident beam of 2.3–2.5MeV³He ions allows the simultaneous quantification of carbon, beryllium and deuterium on the collectors via the $^{12}\text{C}(^3\text{He}, \text{p})^{14}\text{N}$, $^9\text{Be}(^3\text{He}, \text{p})^{11}\text{B}$ and $^2\text{H}(^3\text{He}, \text{p})^4\text{He}$ reactions. Figure 1 depicts the geometry of the rotating collector considered here. Thermocouples in this region under the central divertor tile indicate local temperatures of ~ 80-150°C. The recessed position and view of the inner divertor give a deposition-dominated location, suited to investigation of transport to remote areas and strike point locations.

3. MODELLING

Erosion, deposition and material migration in JET have previously been studied using models such as the 3-D Monte Carlo code ERO [4], which provides a detailed treatment of plasma-surface interaction and transport processes. The approach here differs in its increased emphasis on long term changes in erosion/deposition and increased use of experimental data. Since the whole collector lifetime of thousands of pulses is modelled, transport is necessarily simplified using line of sight assumptions. Sputter cones of eroded material are generated at the strike point, with the deposition on the collector calculated geometrically and a 55 discharge moving sum applied. The focus on the changes in deposition and the assumptions made mean that the magnitude of the deposition profile requires scaling by a (constant, < 1) attenuation factor. The approach used is to find the factor that best fits to the experimental deposition, followed by an examination of the reasonableness and implications of such a value.

For the JET-C case, carbon may be eroded from the main chamber and transported to the divertor, forming hydrocarbon layers that are re-eroded by incident deuterium and re-deposited in remote areas [5]. Similarly, in the ILW case, beryllium may be eroded from the main chamber and deposit/re-erode in the divertor. The re-erosion from the inner strike point is modelled, with its location determined through use of EFIT equilibrium reconstruction [6] and local Langmuir probe flux profiles. Physical and chemical erosion yields are calculated every ~ 30ms EFIT time point using the Roth – Garcia-Rosales formulae, which provide analytical yield equations using fits to experimental and modelling results [7]. These formulae include a treatment of the erosion of weakly bound surface hydrocarbons.

In the ILW case, 80% efficient reflection of beryllium from the tungsten divertor is also included [8], assuming an incident flux containing a 0.2% beryllium impurity [2]. The sputtering and reflection contributions to deposition on the collector are not entirely mutually compatible. A tile completely covered with beryllium will maximize the sputtering contribution, but beryllium-beryllium reflection is low. Conversely, low coverage will maximise reflection from the tungsten, but there will be little deposited beryllium to be sputtered. As such, the mean of the deposition due to the two processes is taken, reflecting the fact that on average they contribute similar magnitudes to the modelled deposition, but cannot be simultaneously maximised.

The calculated yields are functions of the incident energy, ion flux and target temperature. The

angle of incidence was assumed to be 60° based on modelled ion trajectories [9], increasing the yield since more energy is deposited in the near-surface region. The incident energy was 50eV, based on an assumption of $T_e = 10\text{eV}$, with $T_i = T_e$ and $E_{in} = 3ZT_e + 2T_i$. Tile surface temperatures are estimated using a linear, temporal fit of thermocouple measurements to selected IR thermography data, typically giving temperatures $\sim 450\text{--}700\text{K}$. Ion fluxes from local Langmuir probes are inputs to the yield calculations, and are multiplied by the resulting yields to give the sputtering source. Since for most ILW conditions physical sputtering is expected to be dominant, the constant ion energy assumption is more vulnerable to deviations causing variations in yields. While there are changes in this and in the impurity content for individual discharges, the smoothing the collector resolution imposes makes the constant assumptions reasonable approximations.

At each time point, cosine cones of sputtered/reflected particles are generated from the target, with the peak shifted 30° poloidally below the tile surface normal to preserve some of the directionality of the incident ions. The upper and lower line of sight acceptance angles to the collector are calculated for each strike point, with deposition calculated by integrating the cones between these bounds. Strike points with no line of sight to the collector (e.g. those on tile 4) are neglected, save for the application of a small background re-erosion from the collector surface. Quartz Micro Balance (QMB) measurements have shown that moving the strike point from tile 3 to 4 changes this from a deposition-dominated to an erosion-dominated region [10].

4. RESULTS

The results from the 2005-07 rotating collector have previously been published in [3]. This data is plotted in Figure 2 with the results of the geometric model, showing considerable qualitative agreement. The modelled results have been scaled by an attenuation factor of 0.12, describing the efficiency of transport of sputtered particles. The model's over-estimate of deposition after discharge 66,000 suggests a physical reduction in this parameter later in the campaign. For the 2007-09 period, configurations generally varied over shorter periods than the 55 discharge (~ 2 days) resolution, but broad features of the deposition and dependence on plasma configurations are identifiable. Table 1 shows that though the deposition per pulse was reduced by a factor of ~ 2 , much of this was due to decreased line of sight time to the collector (Figure 3). The increased strike point time on tile 4 for 2007-09 implies that the remaining difference may be due to increased re-erosion from the collector surface [10].

The measured and modelled (with attenuation factor 0.64) beryllium deposition on the 2010-12 ILW collector is shown in Figure 4. There is reasonable qualitative agreement, though the relative lack of distinctive features makes comparison harder. The profile is more constant than for the carbon case, though there is some variation mostly due to changes in ion fluxes and strike points. Table 1 shows that the ILW deposition rate as a function of line of sight time was reduced by a factor of 7-9 relative to JET-C, and by 13-17 when normalised to the larger solid angle subtended by the JET-C collector.

5. DISCUSSION

5.1. CARBON

The agreement between the modelled and experimental results supports previous work showing that line of sight divertor transport from the strike point to remote regions is the dominant process [11]. The large mean free paths of the sputtered neutrals in the private-flux region imply that most losses of sputtered particles are likely due to ionization and redeposition near their point of origin, before crossing the separatrix. If the attenuation factor of 0.12 is solely due to this local redeposition, the redeposition rate of 0.88 is comparable to rates found from ERO modelling [12].

After discharge 66,000 there are still strong time variations in deposition, but they are less prominent than those found by the model with its fixed attenuation factor (though they have the right time dependence). After this point, there were a greater fraction of high power/ELMy discharges, leading to higher divertor radiated powers and suggesting a higher heat flux to and surface temperature of the collector. This may cause a reduction in the deposition efficiency and change the structure of the deposited layers. Increased surface temperature has been found to decrease deposition on QMBs [3] (though the collector is less thermally isolated, suggesting a smaller temperature rise). ELMs may also drive the formation of particle clusters, which could dominate the deposition during ELMs due to their longer mean free paths [13]. An examination of the ion flux and D-alpha signals in the inner divertor indicates increased detachment in the inner divertor later in the campaign. Though the reduced ion flux during detachment is accounted for in the model through use of Langmuir probe data, detachment may also reduce the physical and chemical sputtering yields [14]. Finally, higher power discharges may cause enhanced re-erosion from the collector surface, reducing the net deposition.

5.2. ILW

The reduction in the beryllium deposition rate on the ILW collector by a factor of 13-17, relative to carbon deposition on the JET-C collectors, is consistent with an observed order of magnitude reduction in both overall ILW divertor deposition [15] and integral deposition on QMBs similarly located under tile 5 [16]. This reduced deposition demonstrates the low long range migration of beryllium in the ILW divertor due to negligible chemical erosion and decreased chemical sputtering and codeposition of beryllium relative to carbon [17]. The attenuation factor of 0.64 implies a redeposition fraction of 0.36, which is comparable to rates found using ERO [6].

The sputtering of tungsten is only expected to be significant during ELMs, with low deposition levels of $\sim 8 \times 10^{12}$ W atoms/cm²/pulse identified using Rutherford Backscattering Spectrometry (RBS). Though there were deposits of $\sim 4 \times 10^{13}$ C atoms/cm²/pulse of carbon measured on the ILW collector, these did not correlate with deuterium deposition, suggesting that codeposition of carbon with deuterium is not dominant for the ILW case. This contrasts with the JET-C case, where the D/C ratio stayed close to 1. For the ILW collector, the D/Be ratio generally decreased during the campaign from ~ 1 to ~ 0.25 . This is attributed to higher power discharges causing increased

collector surface temperatures via increased heat fluxes to the collector and thermal conduction through tile 5. Empirical scaling equations for deuterium retention in beryllium deposits [18] indicate that this decrease is compatible with a moderate temperature increase of $\sim 100\text{K}$.

The prevalence of configurations with strike points on tile 3 (Figure 3) contributed to less temporal variation of deposition on the ILW collector. Although post-mortem analysis indicates permanent deposits on tile 3 are low to zero [15], the beryllium coverage may be expected to vary dynamically during the campaign, causing sputtering and reflection to contribute varying proportions to the deposition. However, both mechanisms depend on geometrical line of sight transport from the strike point. In addition, the opposite dependences of sputtering and reflection on coverage and $(1 - \text{coverage})$ respectively suggests that they are mutually limiting. This is expected to partially neutralise the dependence of deposition on coverage, making it hard to extricate the two mechanisms. However, beryllium deposits have been shown to accumulate on divertor tiles during the ~ 30 limiter discharges at the start of the ILW campaign, before divertor discharges began [19]. It is noted that the deposition found on the collector experimentally exceeds that expected from the model for the first ~ 400 (divertor) discharges. This relatively large deposition suggests a strong sputtering contribution, which dominates during this period due to the initial conditions of high beryllium coverage.

CONCLUSIONS

The time-resolved deposition on rotating collectors in a remote location with a line of sight to the JET inner divertor has been investigated for carbon and ILW operation. A simple geometrical model using experimental data has been shown to qualitatively reproduce the deposition on the collectors. The deposition is dependent on variations in strike point locations and other operating conditions. The deposition rate on the ILW collector is reduced by a factor of 13-17 relative to carbon operation. This decreased deposition in remote locations is indicative of the low long range divertor transport found with an all metal wall due to reduced chemical sputtering/erosion and codeposition. Future work will develop the modelling and understanding of deposition in this and other vessel locations.

ACKNOWLEDGEMENTS

This work was supported by EURATOM and carried out within the framework of the European Fusion Development Agreement. The views and opinions expressed herein do not necessarily reflect those of the European Commission.

REFERENCES

- [1]. G. F. Matthews et al., *Physica Scripta* **T145** (2011) 014001
- [2]. S. Brezinsek et al., *Journal of Nuclear Materials* **438** (2013) S303–S308
- [3]. J. P. Coad et al., *Physica Scripta* **T138** (2009) 014023
- [4]. A. Kirschner et al, *Nuclear Fusion* **40** (2000) 989
- [5]. M. Mayer et al., *Physica Scripta* **T111** (2004) 55

- [6]. L. L. Lao et al., Nuclear Fusion **30** (1990) 1035
- [7]. J. Roth and C. Garcia-Rosales, Nuclear Fusion **36** (1996) 1647
- [8]. A. Kirschner et al., these proceedings
- [9]. K. Schmid et al., Nuclear Fusion **50** (2010) 105004
- [10]. H. G. Esser et al., Journal of Nuclear Materials **390–391** (2009) 148
- [11]. J. P. Coad et al., Physica Scripta **1999** (1999) 7
- [12]. A. Kirschner et al., Journal of Nuclear Materials **337–339** (2005) 17
- [13]. A. Kreter et al. Physical Review Letters **102**, 045007
- [14]. S. Brezinsek et al, Journal of Nuclear Materials **390–391** (2009) 267
- [15]. A. Widdowson et al., Physica Scripta **T159** (2014) 014010
- [16]. H. G. Esser, these proceedings
- [17]. S. Brezinsek, these proceedings
- [18]. G. de Temmerman et al., Nuclear Fusion **49** (2009) 042002
- [19]. K. Krieger et al., Journal of Nuclear Materials **438** (2013) S262

Campaign	05-07	07-09	10-12	10-12 (/ Ω)
Impurity	C	C	Be	Be
Deposition/ pulse 10^{15} at/cm ²	6.89	3.18	0.79	0.44
Deposition/ LOS time 10^{15} at/cm ² /s	0.82	0.63	0.09	0.05

Table 1: Average deposition on collectors per pulse and per second of time the strike point had a line of sight (LOS) to the collector. The last column shows the equivalent beryllium deposition rates after normalising to the solid angle Ω subtended by the carbon collectors.

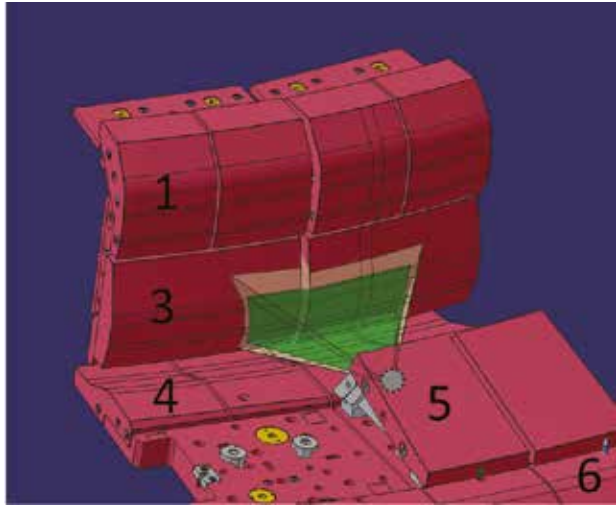

Figure 1: View of the MkIIHD (carbon) inner divertor, with tile numbers labelled. The rotating collector is located under central tile 5 and views tile 3. The projections depict the 'umbra' and 'penumbra' of the view from the collector.

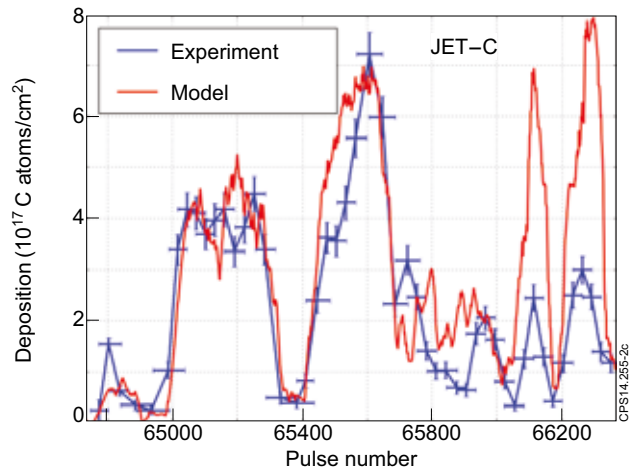

Figure 2: Carbon deposition on the rotating collector for the 2005–07 carbon campaign found by NRA (blue), and model scaled by 0.12 attenuation factor (red). The NRA measurement process is Poissonian, giving $n^{-1/2}$ errors on the deposition. The pulse number error bars show the bounds of the moving sum of deposition imposed by the finite slit width.

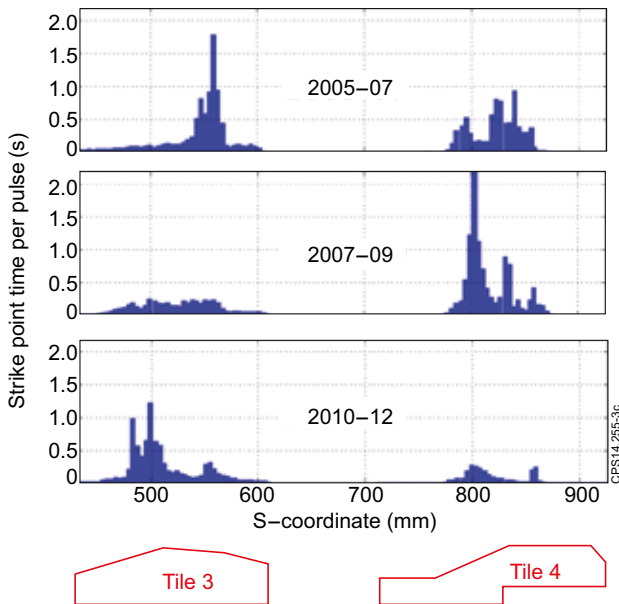

Figure 3: Campaign-averaged inner strike point distributions. The s -coordinate system follows the divertor surface poloidally. For 2010–12 operation there were also a significant number of strike points on tile 1, part of which has an acute line of sight to the collector for the ILW geometry.

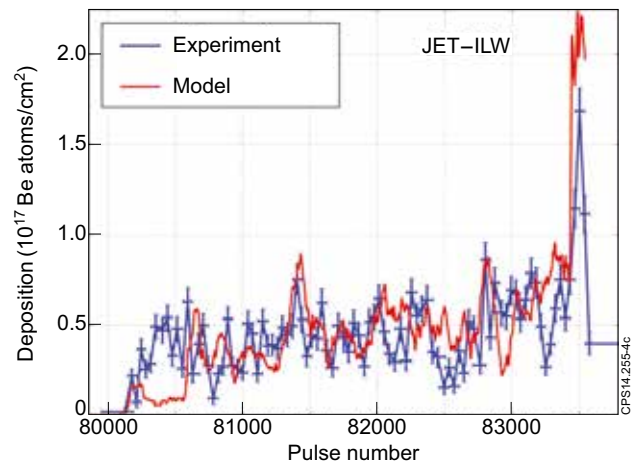

Figure 4: Beryllium deposition on the collector for 2010–12 ILW operation found by NRA (blue), and model scaled by 0.64 attenuation factor (red). The large horizontal error bars at $\sim 83,600$ indicate that the collector ended its rotation ~ 200 pulses before the end of the campaign, resulting in high aggregate deposition. The modelled deposition for the remaining ~ 200 pulses has been allocated to this stopping point accordingly.