

A.J.N. Batista, A. Neto, M. Correia, A.M. Fernandes, B.B. Carvalho, J.C. Fortunato,
J. Sousa, C.A. F. Varandas, F. Sartori, M. Jennison and JET EFDA contributors

ATCA Control System Hardware for the Plasma Vertical Stabilization in the JET Tokamak

“This document is intended for publication in the open literature. It is made available on the understanding that it may not be further circulated and extracts or references may not be published prior to publication of the original when applicable, or without the consent of the Publications Officer, EFDA, Culham Science Centre, Abingdon, Oxon, OX14 3DB, UK.”

“Enquiries about Copyright and reproduction should be addressed to the Publications Officer, EFDA, Culham Science Centre, Abingdon, Oxon, OX14 3DB, UK.”

The contents of this preprint and all other JET EFDA Preprints and Conference Papers are available to view online free at www.iop.org/Jet. This site has full search facilities and e-mail alert options. The diagrams contained within the PDFs on this site are hyperlinked from the year 1996 onwards.

ATCA Control System Hardware for the Plasma Vertical Stabilization in the JET Tokamak

A.J.N. Batista, A. Neto, M. Correia, A.M. Fernandes, B.B. Carvalho, J.C. Fortunato,
J. Sousa, C.A. F. Varandas, F. Sartori¹, M. Jennison¹ and JET EFDA contributors*

JET-EFDA, Culham Science Centre, OX14 3DB, Abingdon, UK

Associação EURATOM/IST Instituto de Plasmas e Fusão Nuclear, 1049-001 Lisbon, Portugal

²*EURATOM-UKAEA Fusion Association, Culham Science Centre, OX14 3DB, Abingdon, OXON, UK*

** See annex of F. Romanelli et al, "Overview of JET Results",
(Proc. 22nd IAEA Fusion Energy Conference, Geneva, Switzerland (2008)).*

Preprint of Paper to be submitted for publication in Proceedings of the
16th IEEE NPSS Real Time Conference, Beijing, China.
(10th May 2009 - 15th May 2009)

ABSTRACT.

A multi-input-multi-output controller for the plasma vertical stabilization was implemented and installed on the Joint European Torus tokamak. The system can attain a control-cycle time of approximately $30\mu\text{s}$ using $\times 86$ multi-core processors but targets $10\mu\text{s}$ via Field Programmable Gate Array (FPGA) based processing. The hardware, complying with the Advanced Telecommunications Computing Architecture (ATCA) standard, was in-house designed and implemented to achieve the required performance and consists of: A total of 6 synchronized ATCA control boards, each one with 32 analog input channels which provide up to 192 galvanically-isolated channels, used mainly for magnetic measurements. Each board contains an FPGA, which performs digital signal processing and includes a PCI Express communications interface; An ATCA rear transition module, which comprises up to 8 galvanically-isolated analog output channels to control the fast radial field amplifier ($\pm 10\text{kV}$, $\pm 2.5\text{kA}$). An optical link to digitally control the enhanced radial field amplifier ($\pm 12\text{kV}$, $\pm 5\text{kA}$). Up to 8 EIA-485 digital inputs for timing and monitoring information; An ATCA processor blade with a quad-core processor, where the control algorithm is presently running, connected to the 6 ATCA control boards through the PCI Express interface. All FPGAs are interconnected by low-latency links via the ATCA full-mesh backplane, allowing all channel data to be available on each FPGA running an upcoming distributed control algorithm.

1. INTRODUCTION

THE Joint European Torus (JET) is the largest tokamak [1] operating in the world [2]. Strong magnetic fields, which confine the plasma inside the chamber, are generated with several coils. The plasma is forced to be vertically elongated to achieve better characteristics, however such kinds of plasma are vertically unstable and need to be controlled in closed loop [3]. Plasma disruptions may occur due to the lack of control of the instability inducing heavy loads on the machine's vessel.

The Vertical Stabilization (VS) system purpose is to control the instability by actuating on a set of Poloidal Field (PF) coils, which generate a radial magnetic field.

The VS controller described in this paper is the evolution of a previous system architecture concept [4], complying with the specifications of the plasma control upgrade project task 2 of JET [5]. One of the most important project requirements is the execution of the control closed loop-cycle within $50\mu\text{s}$ with a maximum jitter of $2.5\mu\text{s}$.

The former VS controller of JET [6], based on the old C40 microprocessor and VME standard, is currently working simultaneously with the new ATCA VS controller. The outputs of the two systems can be switched during JET operation, allowing the control of the PF coils by one of the VS controllers as illustrated on Fig.1.

The new VS controller runs continuously, although JET is a pulsed machine, making the system particularly relevant for future fusion devices like ITER [7], where subsystems must run in steady-state operation. The following sections describe the system's hardware and firmware. The software framework is described in [8].

2. SYSTEM OVERVIEW

The new VS controller hardware, Fig.2, is based on the Advanced Telecommunications Computing Architecture (ATCA) standard [9]. Two communications fabrics are used simultaneously on the ATCA backplane, the PCI Express [10] and the Aurora [11] in star and full-mesh topologies respectively.

2.1. Architecture

The system's architecture is presented on Fig.3. The analog signals from some of JET's diagnostics (mainly magnetic measurements) are connected directly to the galvanically-isolated (1 kV) inputs of the ATCA-MIMO-ISOL boards. The signals are sampled at 2 MSPS (18-bit resolution), digitally filtered and decimated to 20 kHz before they are sent, in real-time, to the ATCA-CONTROLLER-PCIe board, via PCI Express full-duplex communication links, making use of the ATCA backplane.

One of the four processors of the ATCA-CONTROLLER-PCIe searches, by means of polling, a buffer memory for the decimated data arrival of the next control cycle [8]. Upon arrival the decimated data are processed by the control algorithm and the result is sent back to one of the ATCA-MIMO-ISOL boards. The resulting data from the control algorithm is used to feed the DACs and the digital optical link of the ATCA-MIMO-ISOL.

Presently the PF coils of JET tokamak are driven by the Fast Radial-Field Amplifier (FRFA) [12] which is connected to the DACs of the VS controller. An Enhanced Radial-Field Amplifier (ERFA) [13] was installed recently to replace the FRFA and is controlled digitally through the optical link of the ATCA VS system, see Fig.1.

To decrease the control-cycle time of the centralized algorithm processing, mentioned above, an alternative or complementary distributed algorithm processing is possible using the Field Programmable Gate Arrays (FPGAs) and the full-mesh Aurora fabric. An upcoming distributed control algorithm will be implemented on the FPGAs of the ATCA-MIMO-ISOL boards, allowing parallel data processing. Due to the full-mesh Aurora fabric, a Multi-Input-Multi-Output (MIMO) architecture was achieved, where the data of any input of the ATCA VS system can be present on any FPGA, in real-time.

2.2. Synchronization

The PCI Express endpoint, implemented on the ATCA-MIMO-ISOL's FPGA, must be synchronized with the ATCA-CONTROLLER-PCIe's PCI Express switch. For that purpose, it's necessary to pass a 100MHz SSC clock and a reset signal through the ATCA backplane. The ATCA (PICMG 3.4) standard has no specification for such sideband signals. To solve this problem, two user-defined backplane lines were used, as seen on Fig.4.

It was also necessary to synchronize the ATCA VS system with JET's Composite Timing and Trigger System (CTTS) [14]. For that purpose, a 2 MHz clock and a trigger need to be propagated through the ATCA backplane.

To fully synchronize the DMA engines of the ATCA-MIMO-ISOL boards, two additional signals

are also transmitted on the backplane.

Since the two available user-defined lines of the ATCA backplane were already taken by the PCI Express sideband signals, the only option was to violate the ATCA standard and make use of four lines specified for telecomm clocks, which are not needed on the VS control system hardware. Fig.5 shows the four signals that override the ATCA specification.

The CTTS trigger signal is used to reset and synchronize the absolute-time counter of each ATCA-MIMO-ISOL board. The DMA enable signal is used to synchronize the decimated data sent to the ATCA-CONTROLLER-PCIe memory buffer and is activated by the software.

The decimated data is time-stamped with the control-cycle absolute time, since the last trigger, and is sent simultaneously by all ATCA-MIMO-ISOL cards to the host's (ATCA-CONTROLLER-PCIe) memory buffer, with the exception of one card designated as master (defined as ATCA slot hardware address 3). The master is the last one of the six boards to send data to the host (250ns delay).

The host, at the end of the control cycle, starts polling the memory buffer to detect an increment on the cycle time-stamp (50 °s steps) of the master board. Upon increment detection the host gets the decimated data of all boards from the memory buffer, for algorithm processing.

The control-cycle jitter is minimized with the polling scheme relying only on one ATCA-MIMO-ISOL board.

C. Performance

The system delays associated with the PCI Express fabric, without the digital signal processing and the control algorithm processing times, can be consulted on Fig. 6. The links between the endpoints and the switch are x1 and the packets have a constant payload of 172 bytes resulting on an effective bandwidth of 1.76 Gbit/s.

Figure 7 shows the Aurora full-mesh fabric associated delays, also without processing times. Links between Aurora endpoints are x1 and the effective bandwidth it will depend of the upcoming distributed control algorithm. The optical link is equally implemented using Aurora and the delays are similar to the ones of Fig.7 with the additional propagation time through the optical fiber, which is about 500ns.

The 100-tap FIR filter of the digital signal processing on the FPGA adds around 20µs of intrinsic delay. The control algorithm processing time, measured on host, is approximately 30µs and the control-cycle jitter is less than 800ns.

3. SYSTEM BUILDING BLOCKS

An ATCA shelf, six ATCA-MIMO-ISOL boards, one ATCA-CONTROLLER-PCIe board, and an ERFA interface board, implement the VS control system hardware of JET. The next sub-sections describe the hardware within each type of board.

3.1. ATCA-MIMO-ISOL board

It is an in-house developed board complying with the ATCA specification, highly modularized, and

with an optional Rear Transition Module (RTM), Fig.8. The design is based on an FPGA connected to FLASH and DDR memories, ADCs, DACs, EIA-485 IOs, optical SFP port and to the ATCA full-mesh backplane. Fig. 9 summarizes the board's architecture, including the RTM.

The board's main characteristics are:

1) Analogue inputs.

- Number of channels: 32 (differential).
- Dynamic range: -32V to $+32\text{V}$.
- Resolution: 18 bits.
- Sampling rate: 2 MSPS.
- Impedance: $> 100\text{k}\Omega$
- Voltage isolation: 1 kV.
- Anti-aliasing filter: 500kHz passive low-pass 3rd order Butterworth.
- Connector: Male D 37-way

2) Analogue outputs.

- Number of channels: 8 (differential).
- Dynamic range: -10V to $+10\text{V}$.
- Resolution: 16 bits.
- Output current: 45mA.
- Voltage isolation: 1kV.
- Connector: Female D 37-way.

3) Digital IO signals.

- Number of channels: 8 (EIA-485).
- Trigger (input), Clock (input), 6 user defined (inputs).
- Connector: Female D 37-way

4) Optical interface.

- SFP full-duplex port.
- Aurora.

5) Trigger specifications.

- Master trigger: external or internal (software).
- Negative edge, minimum pulse width of 500ns.

6) Clock specifications.

- Master clock: 2 MHz (external or internal).

7) Time stamping specifications.

- Time resolution: $1\mu\text{s}$.
- Maximum time count: over 30 minutes.

- 8) Storage capabilities.
 - 512 MB of SODIMM DDR2 DRAM memory.
 - 512 MB of CompactFlash card memory.
- 9) Processing capabilities.
 - FPGA: Xilinx® Virtex™ 4 (XC4VFX60/XC4FX100).
- 10) ATCA specifications.
 - Single front ATCA slot with RTM slot.
 - ATCA Fabric channel 1 (x1 PCI Express).
 - ATCA Fabric channels 3 to 13 (x1 Aurora).

3.2. ATCA-CONTROLLER-PCIe board

This in-house developed board, depicted on Fig.10, complies with the ATCA specification and includes an auxiliary RTM power supply. The design is based on a PCI Express switch connected to the ATCA full-mesh backplane and to a μ ATX motherboard with a quad-core processor. The board architecture is shown on Fig.11.

The board's main characteristics are:

- 1) Processing.
 - Intel quad-core.
- 2) Memory.
 - 2 GB of DIMM DDR2 DRAM.
 - HDD 80 GB.
- 3) ATCA specifications.
 - Double front ATCA slot with RTM slot.
 - ATCA Fabric channels 2 to 13 (x1 PCI Express).
- 4) Interfaces.
 - Gigabit Ethernet.
 - ATM.
 - RS232.

3.3. ERFA interface board

This board, also in-house developed, is proprietary and complies only with the 3U Eurocard form factor. Designed exclusively to add an optical interface and an Aurora endpoint to the ERFA amplifier, allows the interconnection to the ATCA VS system for the control and monitoring of ERFA.

4. SYSTEM FIRMWARE

As vital as the ATCA-MIMO-ISOL hardware is the board's FPGA firmware. The firmware was

developed in Verilog language and includes serializers, deserializers, FIRs, decimators, CRC engines, packet engines, DMAs, PCI Express endpoint, Aurora endpoints, timing and synchronization logic, etc. Fig.12 illustrates the firmware architecture.

Figure 13 shows the PCI Express packet payload built by the firmware packet engine on each control cycle. The header and footer are equal and are used by the host for packet arrival validation.

CONCLUSION

The new vertical stabilization architecture has been running in parallel with the previous version of the system since the summer of 2008 and it was already used several times to control the machine in closed loop. Several consecutive weeks of operation with no faults were already achieved, with the system running in real-time continuously.

The developed ATCA system can attain a control-cycle time around 30 μ s using a quad-core processor, Linux OS with RTAI, C++ language and the PCI Express fabric. Presently the control cycle is programmed for a conservative time of 50 μ s with a measured jitter below 800ns.

The FPGAs, currently, are only performing digital signal processing, communications, timing and synchronization tasks.

An upcoming distributed control algorithm will be implemented on the FPGAs, making use of the Aurora full-mesh fabric and the authors hope to achieve the targeted control-cycle time of 10 μ s.

ACKNOWLEDGEMENTS

Plasma Control Upgrade (PCU) Task 2 is a JET enhancement project within the EFDA-JET work programme performed as an EURATOM collaboration between IST and UKAEA/JET. This work has been carried out within the framework of the European Fusion Development Task Agreement, with financial support from the European Communities. The views and opinions expressed herein do not necessarily reflect those of the European Commission and the EFDA Associates.

REFERENCES

- [1]. J. Wesson, Tokamaks. Oxford, Oxfordshire: Clarendon, 2004.
- [2]. F. Romanelli, et al., "Overview of JET results" in Proc. 22st IAEA Fusion Energy Conf., Geneve, 2008.
- [3]. R. Albanese, E. Coccorrese, and G. Rubinacci, "Plasma modeling for the control of vertical instabilities in tokamaks" Nuclear Fusion, **29**, no. 6, 013–1023, 1989.
- [4]. A.J.N. Batista, J. Sousa, and C.A.F. Varandas, "ATCA digital controller hardware for vertical stabilization of plasmas in tokamaks" Review of Scientific Instruments, **77**, no.10F527, Oct. 2006.
- [5]. F. Sartori, et al., "The JET PCU project: An international plasma control project," Fusion Engineering and Design, **83**, no. 2-3, 202–206, April 2008.

- [6]. F. Sartori, M. Garriba, R. Litunovsky, F. Milani, and S. Puppini, "DSP control of the fusion plasma configuration of JET," in Proc. IEEE Real Time Conf., 1995.
- [7]. K. Kurihara, et al., "Plasma control systems relevant to ITER and fusion power plants," Fusion Engineering and Design, **83**, no. 7-9, 959–970, Dez. 2008.
- [8]. A. Neto, et al., "MARTE: A multi-platform real-time framework," IEEE Trans. on Nuclear Science, submitted for publication.
- [9]. <http://www.picmg.org>
- [10]. <http://www.pcisig.com>
- [11]. <http://www.xilinx.com>
- [12]. T. Bonicelli, M. Garriba, F.L. Mondino, and P. Noll, "Analysis and specification of the performances of the new JET amplifier for the vertical stabilization," in Proc. 15th SOFE Conf., 1993, 13–16.
- [13]. D. Ganuza, et al., "The Design and Manufacture of the Enhanced Radial Field Amplifier (ERFA) for the JET Project," in Proc. 25th Symposium on Fusion Technology Conf., Rostock, 2008.
- [14]. C. Terella, and I. Young, "CTTS: the composite timing and trigger system of the JET machine," in Proc. of the International Conference on Computing in High Energy Physics 97, Berlin, 1997.

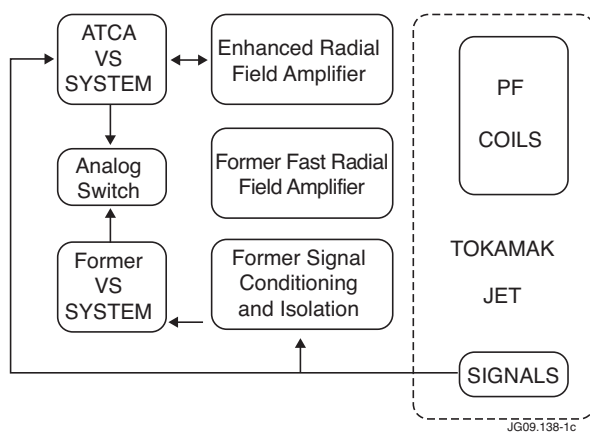

Figure 1: ATCA VS controller coexisting with former VS system.

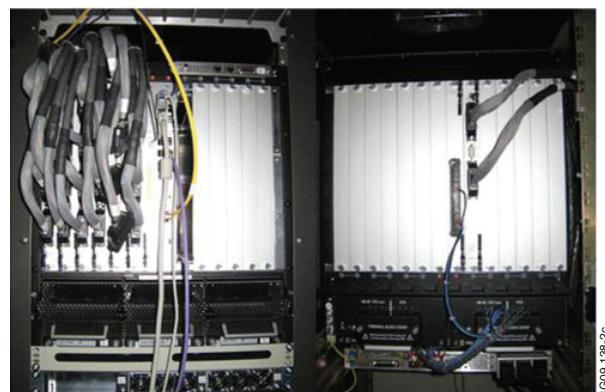

Figure 2: ATCA VS system front and rear views in JET cubicle.

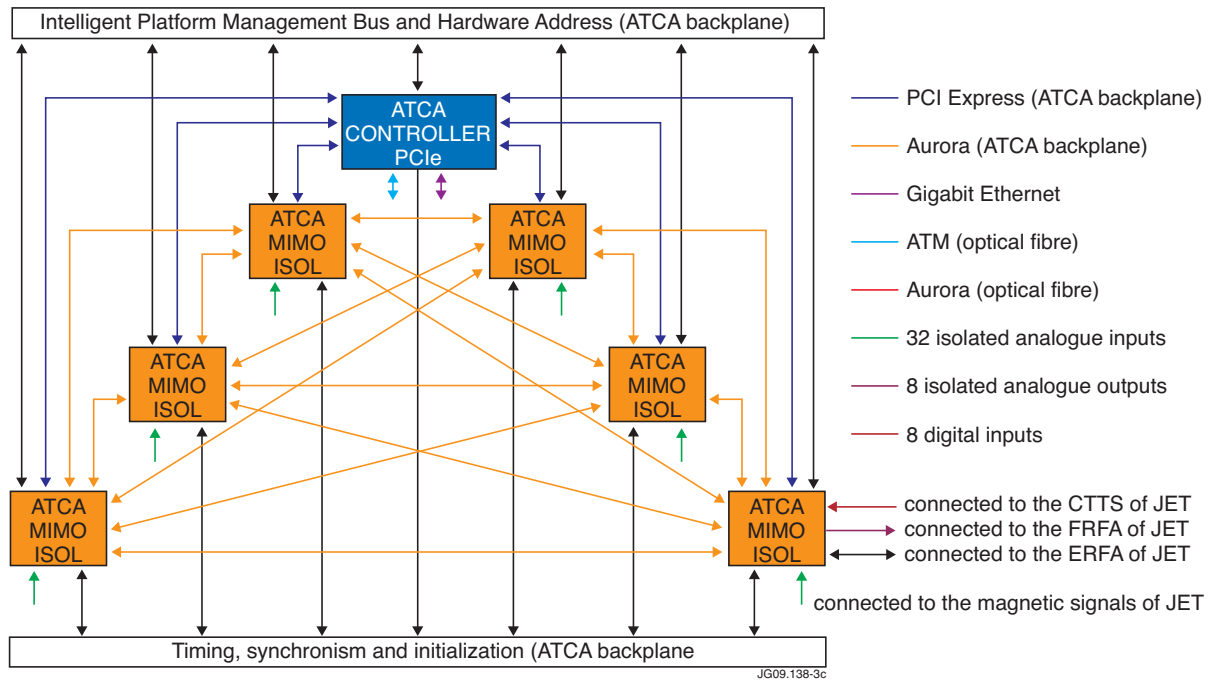

Figure 3: ATCA VS system hardware architecture.

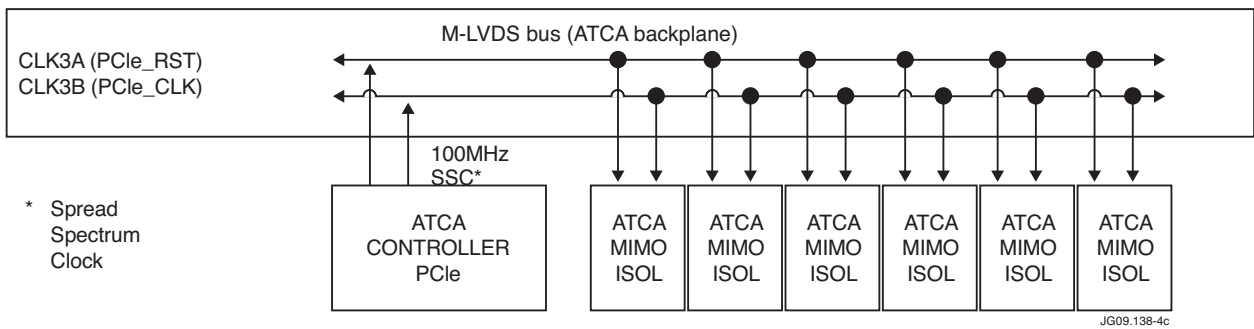

Figure 4: PCI Express synchronization using the user defined M-LVDS lines of the ATCA backplane to propagate the sideband signals.

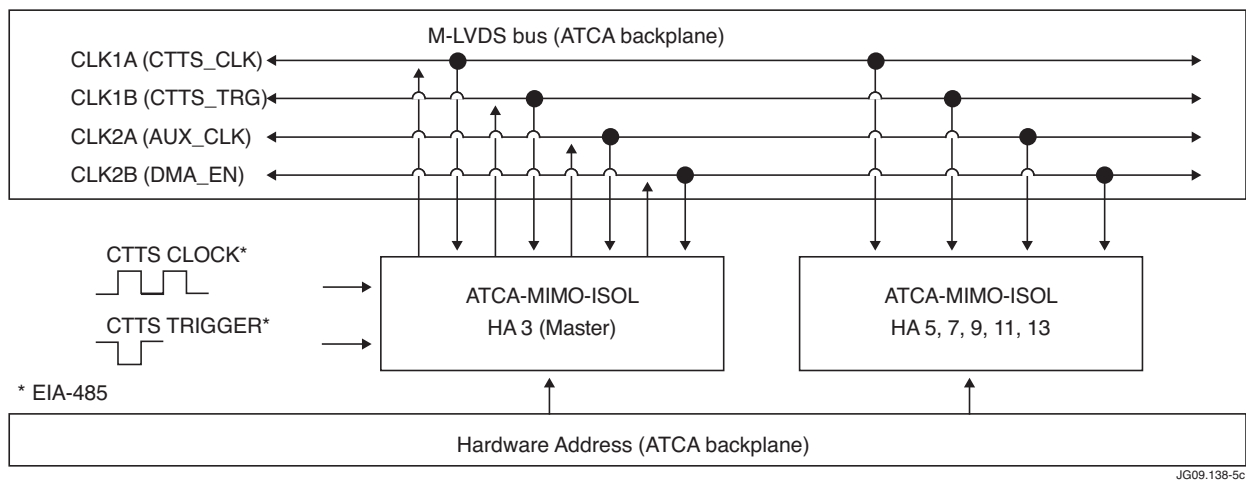

Figure 5: Signals overriding the M-LVDS lines of the ATCA specification. The CLK1A, CLK1B, CLK2A, and CLK2B on the ATCA standard are telecomm network clocks which were replaced on the VS system by the CTTS clock, CTTS trigger, DMA enable, and an auxiliary clock.

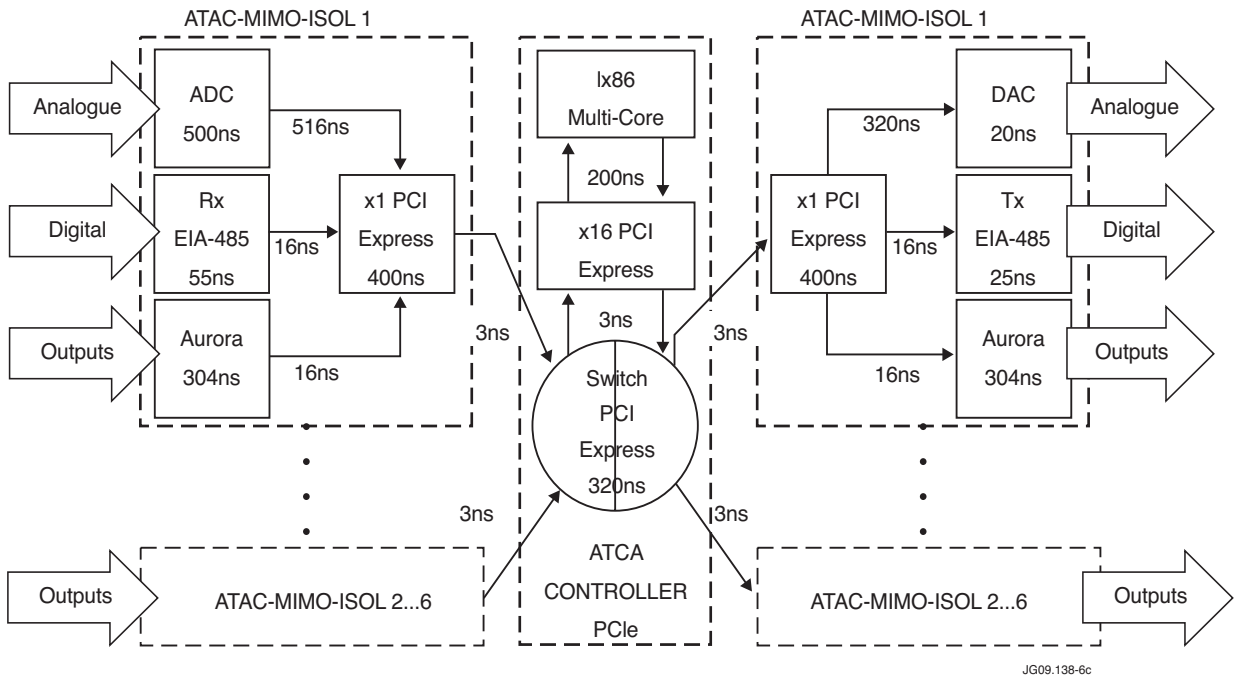

Figure 6: Delays using the PCI Express fabric.

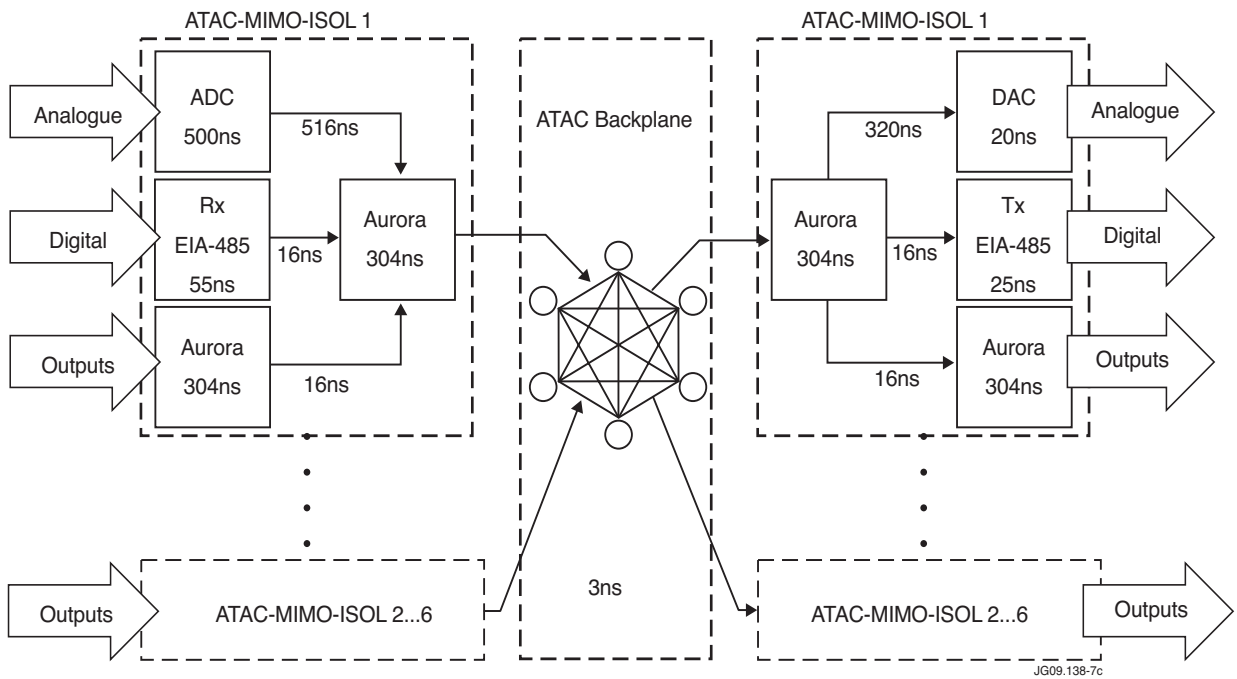
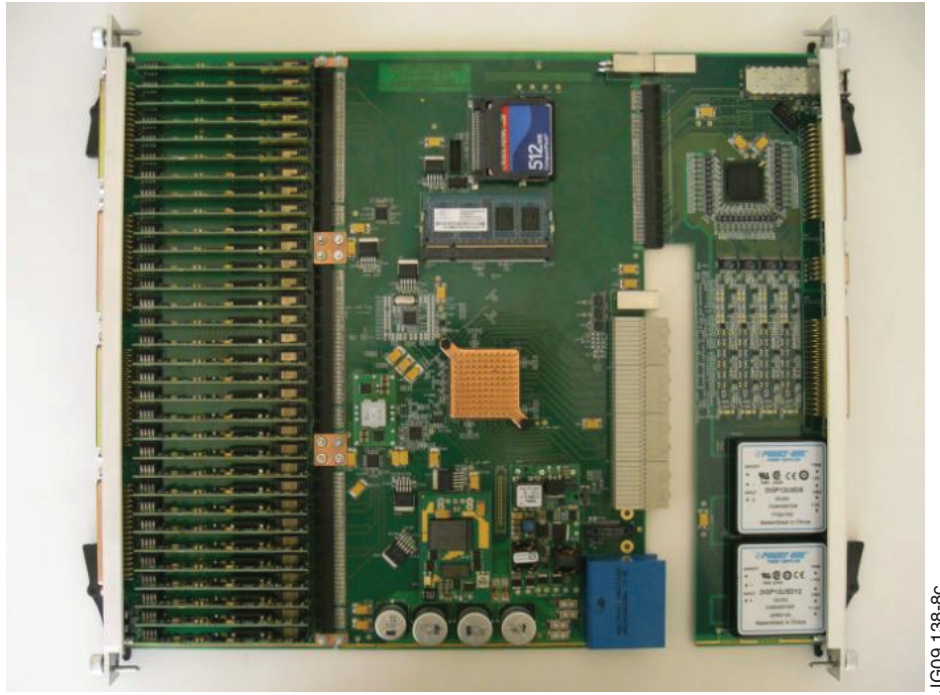

Figure 7: Delays using the Aurora fabric.



JG09.138-8c

Figure 8: ATCA-MIMO-ISOL board top view (including the RTM).

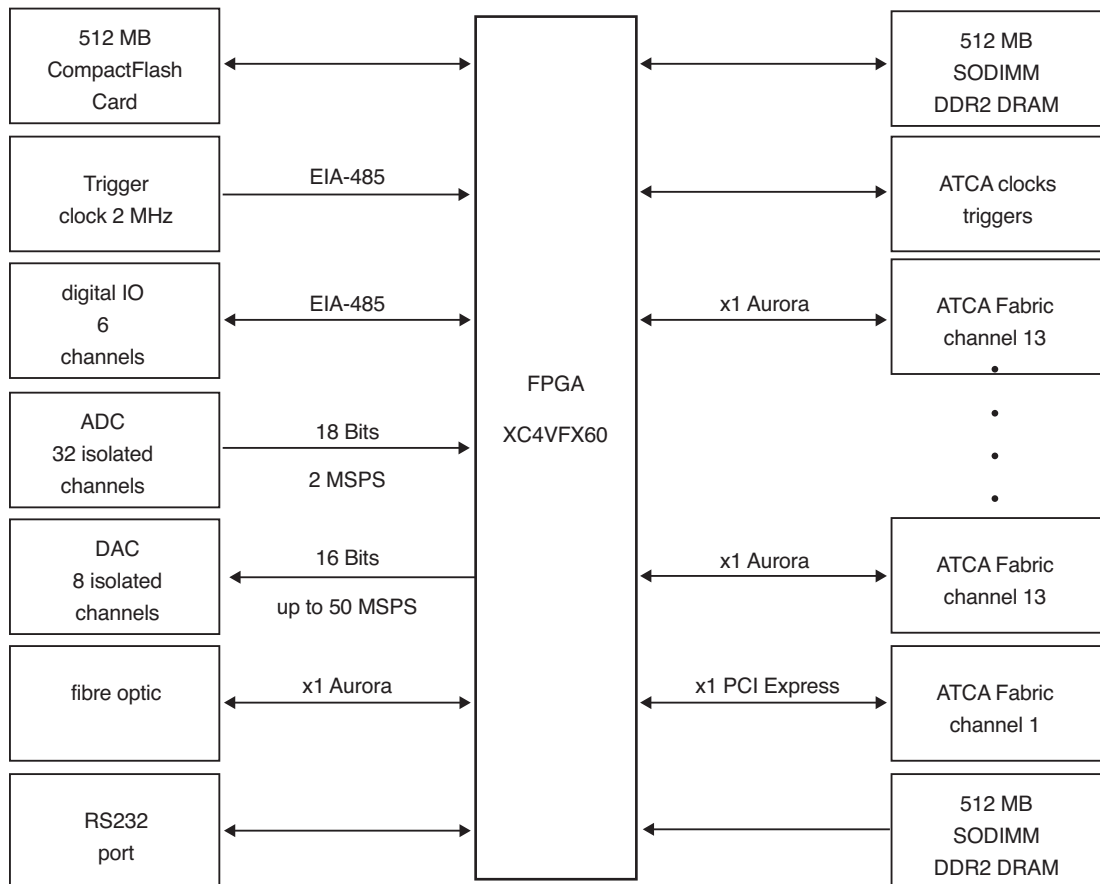
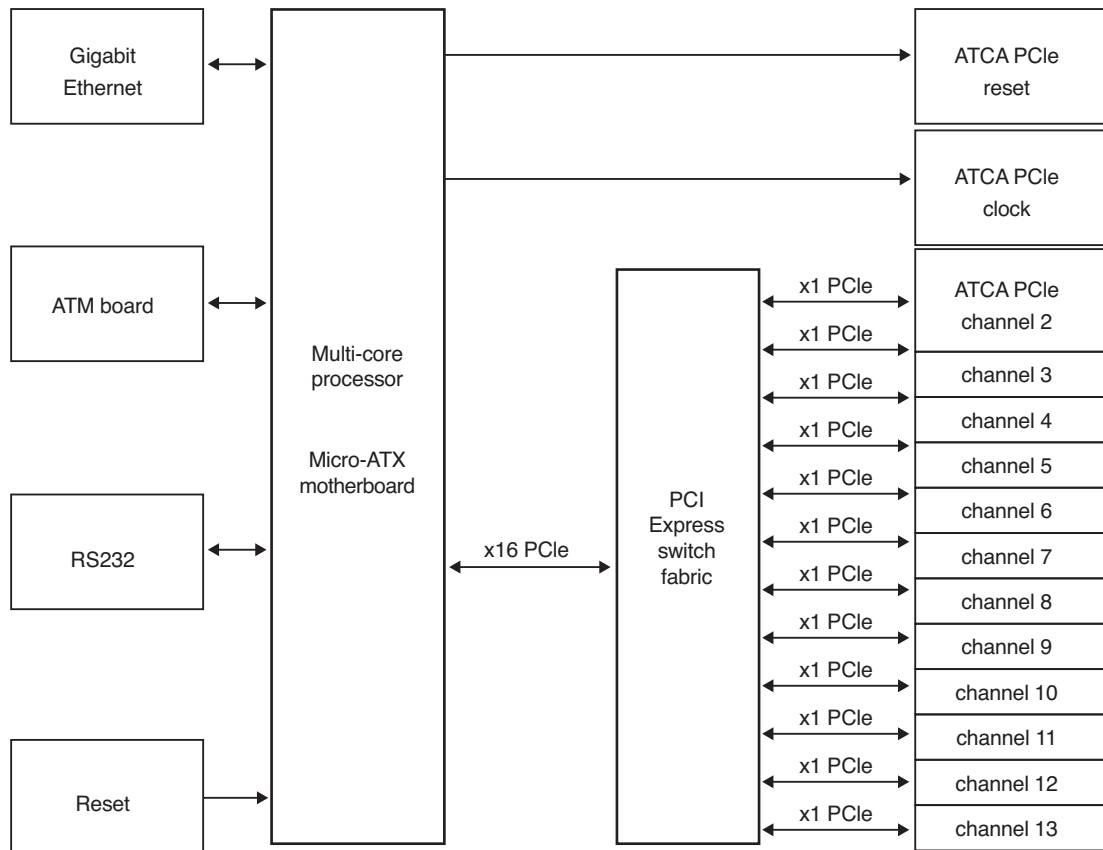

Figure 9: ATCA-MIMO-ISOL board architecture.



JG09.138-10c

Figure 10: ATCA-CONTROLLER-PCIe board (RTM power supply not shown).



JG09.138-11c

Figure 11: ATCA-CONTROLLER-PCIe board architecture.

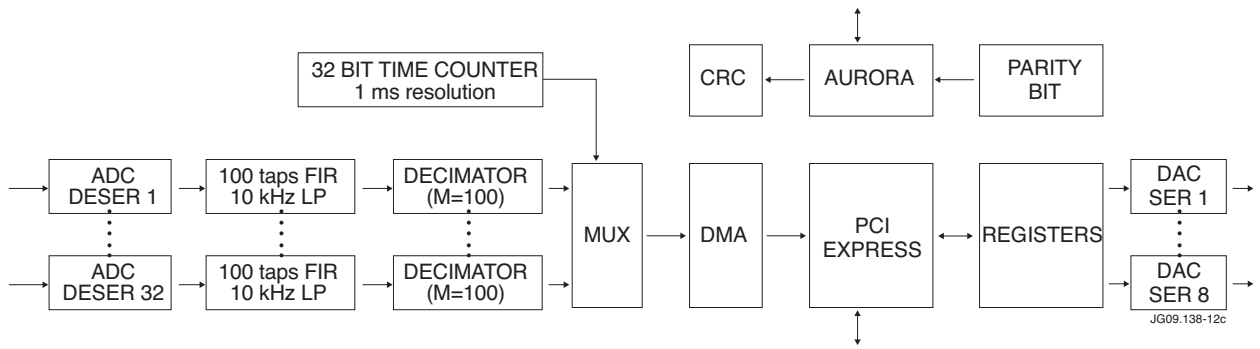

Figure 12: Firmware architecture (simplified).

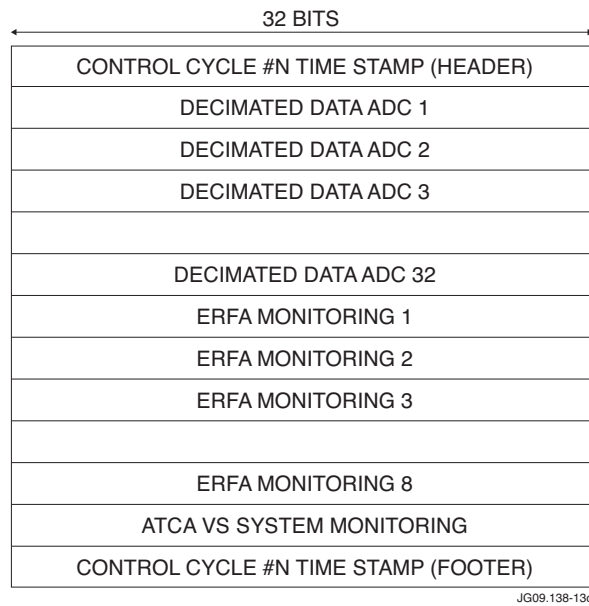

Figure 13: PCI Express packet payload on each control cycle.