EFDA-JET-CP(05)02-44

G. De Temmerman, M.J. Rubel, J.P. Coad, R.A. Pitts, J.R. Drake
and JET-EFDA contributors

Mirror Test for ITER: Optical Characterisation of Metal Mirrors in Divertor Tokamaks

Mirror Test for ITER: Optical Characterisation of Metal Mirrors in Divertor Tokamaks

G. De Temmerman¹, M.J. Rubel², J.P. Coad³, R.A. Pitts⁴, J.R. Drake²
and JET EFDA contributors^{*}

¹*Institute of Physics, University of Basel, CH-4056 Basel, Switzerland*

²*Alfvén Laboratory, KTH, Association EURATOM – VR, 100-44 Stockholm, Sweden*

³*Culham Science Centre, EURATOM-UKAEA Fusion Association, Oxon OX14 3DB, UK*

⁴*Centre de Recherches en Physique des Plasmas, Association EURATOM, Confédération Suisse, EPFL,
1015 Lausanne, Switzerland*

** See annex of J. Pamela et al, “Overview of JET Results ”,
(Proc.20th IAEA Fusion Energy Conference, Vilamoura, Portugal (2004).*

Preprint of Paper to be submitted for publication in Proceedings of the
EPS Conference,
(Tarragona, Spain 27th June - 1st July 2005)

"This document is intended for publication in the open literature. It is made available on the understanding that it may not be further circulated and extracts or references may not be published prior to publication of the original when applicable, or without the consent of the Publications Officer, EFDA, Culham Science Centre, Abingdon, Oxon, OX14 3DB, UK."

"Enquiries about Copyright and reproduction should be addressed to the Publications Officer, EFDA, Culham Science Centre, Abingdon, Oxon, OX14 3DB, UK."

INTRODUCTION

All optical systems in ITER will be based on metallic mirrors. The mirrors, as plasma-facing components, may undergo erosion and re-deposition processes [1] which may influence their optical properties, i.e. reflectivity, which would have a negative impact on spectroscopy signals [2,3]. Tests of first mirrors have therefore been initiated at several machines [4-6], including JET [4] and TCV where dedicated programme has been performed in which small mirror samples are exposed to a variety of divertor plasma configurations. The aim of this paper is to give a brief overview of the tests planned at JET and the experiments underway on TCV.

1. EXPERIMENTAL PROGRAMME AT JET AND TCV

The choice of JET as a facility for First Mirror Testing (FMT) is a consequence of several unique features of this machine: (a) a divertor tokamak with an ITER relevant configuration, (b) plasma pulses of 20s, (c) beryllium, tritium and carbon environment and (d) comprehensive programme of erosion and deposition studies running in parallel with the mirror tests. The JET FMT aims at the study of morphology changes occurring on surfaces of selected mirror materials: polycrystalline molybdenum and stainless steel. The inclusion of the FMT within the framework of Tritium Retention Studies (TRS) [7] will permit erosion and re-deposition processes to be monitored during the mirror exposure using a set of dedicated tools such as rotatable deposition monitors and quartz microbalances (QMB) [8,9]. Tested mirror samples are being installed in the vicinity of these monitoring devices. The experiment itself will be performed over an approximate period of two years. Mirrors (flat front and angled at 45°) have been manufactured and installed in cassettes of pan-pipe shape placed in several locations of interest to ITER: two on the main chamber wall and three in the divertor (inner, outer and base). The photographs in Fig.1 illustrate the two mirror types (Fig.1(a)), the cassettes (Fig.1(b)), the assembled bracket for the main chamber wall (Fig.1(c)) and two cassettes installed in the divertor base. The bracket construction is compatible with the JET remote handling requirements [10].

The relatively long “response” time before the mirrors will be available for ex-situ studies on JET by means of surface analysis and optical methods is a major disadvantage and motivates the pursuit of mirror experiments in other tokamaks, such as TCV, where some specific issues can be addressed on a shorter timescale but perhaps in less “ITER-relevant” circumstances.

At TCV, mirrors made of polycrystalline molybdenum have been installed on a specially designed manipulator inserted from the bottom of the torus into the vessel floor which acts as a target region for a number of different diverted plasma configurations (Fig.2). The manipulator allows samples to be exposed and retrieved without the need for venting the vacuum vessel. A large variety of magnetic equilibria are studied on TCV and the absence of any shutter system protecting the TCV samples means that most exposures are integrated across short campaign periods of 2-3 weeks, including helium glow discharge conditioning which is executed for 5 minutes between each tokamak discharge and for longer periods at the start of each operational day. The manipulator is electrically isolated from the torus and is thus maintained at the local floating potential established during glow discharge.

2. CHARACTERISATION OF MIRRORS

Before any samples are installed (either on JET or TCV) the mirrors are subject to a series of detailed optical studies. Total, specular and diffuse reflectivity of all mirrors is measured by means of a UV-Vis-NIR spectrophotometer equipped with a 110mm diameter integrating sphere, in the wavelength range 250-2500nm. A spectroscopic ellipsometer measures the ellipsometric angles (Ψ , Δ) for the incident angles 45, 55 and 65°; a fit to these data allows both the optical constants of the samples, and the thickness of the deposited film after exposure to be determined. X-Ray Photoelectron Spectroscopy (XPS) is used to characterise the chemical composition of the surface with the mirror surface morphology studied by means of Scanning Electron Microscopy and optical interferometry.

3. EXPERIMENTS AT TCV

A series of three experiments have been performed on TCV, in each case with different distances between the upper protection tile surface and the samples. Two of these exposures (samples 2,3) were made over long periods, with the samples receiving deposited material from many different plasma configurations. A third, dedicated exposure (sample 1), was performed in which a specific diverted equilibrium was used to place the samples deep in the outer divertor SOL of a SNL “standard” TCV discharge. At this position, samples are exposed to rather low neutral fluxes which is likely to be characteristic of those well back from the main plasma-wall interaction area in the ITER divertor. The exposure times and measured deposition on the samples are summarized in Table 1. The SNL standard discharge used for the dedicated exposure experiment is used as a fiducial shot each morning to study the long-term evolution of wall conditions [11]. Figure 3 illustrates the approximate position of the samples in the divertor fan of this equilibrium. During the dedicated exposure period, comprising 19ohmic discharges at $I_p = 320\text{kA}$ and $n_e \sim 6 \times 10^{19}\text{m}^{-3}$ using this configuration, the samples were located at a distance of 10 mm below the tile surface. Although only relatively thin layers were deposited on the samples, it has nevertheless been possible to establish an influence of the deposited layer on the sample reflectivity. In the case of sample 2 on which the thickest layer was deposited (3.9nm), a reflectivity decrease of 6% at 300nm is observed. On this sample, an accumulation of carbon (according to EDX measurements) in the form of a black line can be seen in the shadowed region between the part of the sample covered by the sample holder and the part visible to the plasma. Figure 4(a) shows a SEM picture of this deposit taken in one corner of the sample. Interferometry measurements (Fig.4(b)) demonstrate that the thickness of this deposit is not regular along the perimeter of the sample but has a mean value of about 160nm. A similar but thinner accumulation of material is found on sample 1. Given that TCV is an all carbon machine, deposition of thicker layers might have been expected. Moreover SOLPS5 modelling [12] of the SNL discharge used for the dedicated exposure experiment indicates that a net deposited carbon layer of 3.5nm/s in the region directly above the samples might be expected (assuming the release of CD_4 only at a chemical sputtering yield of 3.5% on the target surfaces and a sticking coefficient of 0.35 [13]). Due to the design of the floor tiles and the samples position (recessed below the tiles

surface), samples cannot ever be exposed to direct ion fluxes. Layers must therefore have been formed by the deposition of hydrocarbon radicals or atomic carbon neutrals released locally by sputtering of the divertor floor tiles. Since the samples are at floating potential during conditioning He glow discharges, the energy of the impinging ions does not exceed $\sim 10\text{eV}$ (acceleration into the sheath) and is therefore below the carbon physical sputtering threshold for He. Removal of any carbon deposited by the tokamak discharges by the He glow can therefore be neglected. Further experiments are required to investigate the apparent contradiction, on sample 2, of a very low deposited thickness in the sample centre, but the very strong deposit near the edges.

CONCLUSION

Metallic mirrors are now installed in JET at locations relevant for ITER (first wall, divertor) and in the vicinity of a range of deposition monitor which form part of the JET Tritium Retention Studies programme. The experiment should give a comprehensive overview of the erosion/deposition mechanisms and their impact on the reflectivity of the mirrors, some of the which are expected to be retrieved in the summer of 2006.

In parallel, first mirror tests are being made in TCV where samples are installed in the divertor SOL remote from the plasma. Very thin layers have been found on the sample surfaces, but strong carbon accumulation has in some cases been found at the border between area open to the plasma and area protected by the sample head. Nevertheless, the 6% reflectivity decrease found for a deposited thickness of $\sim 4\text{nm}$ is of serious concern for the lifetime of mirrors in ITER. Further experiments are required to improve understanding of the various erosion-deposition mechanisms occurring at the TCV samples.

REFERENCES

- [1]. V. Philipps, P. Wienhold, A. Kirschner and M. Rubel, *Vacuum* **67** (2002) 399.
- [2]. V. Voitsenya et al., *Rev. Sci. Instr.* **70** (1999) 790.
- [3]. A. Berdamid et al., *Phys. Scr.* T103 (2003) 109.
- [4]. M. Rubel et al., *Proc. 30th EPS Conf. on Plasma Physics and Controlled Fusion*, St. Petersburg, Russia, July 2003, ECA
- [5]. P. Wienhold et al., *J. Nucl. Mater.* 337-339 (2005) 1116.
- [6]. V. Voitsenya et al., *12th Int. Conf. on Plasma Physics*, Nice, France, October 2004.
- [7]. J.P. Coad et al., *Fusion Eng. Des.*, in press.
- [8]. H.G. Esser et al., *J. Nucl. Mater.*, 337-339 (2005) 84.
- [9]. H.G. Esser et al., *Phys. Scr.* T111 (2004) 129.
- [10]. A. Rolfe, *Fusion Eng. Des.* **36** (1997) 91.
- [11]. R.A. Pitts et al., *J. Nucl. Mater.*, 241-243 (1997) 867.
- [12]. M. Wishmeier, *Phd Thesis, CRPP-EPFL, LRP 799/05* (2005).
- [13]. A. von Keudell et al, *Nucl. Fus.* **39** (1999) 1451.

Sample number	distance below tile surface (mm)	glow discharge (h)	Exposure time	Standard shots	deposited layer (nm)
1	10	1.47	21s	19	0.5
2	15	33.44	3weeks	17	3.9
3	50	21.54	2weeks	9	0.85

JG05.354

Table 1: Exposure time and conditions of the samples for the three experiments.

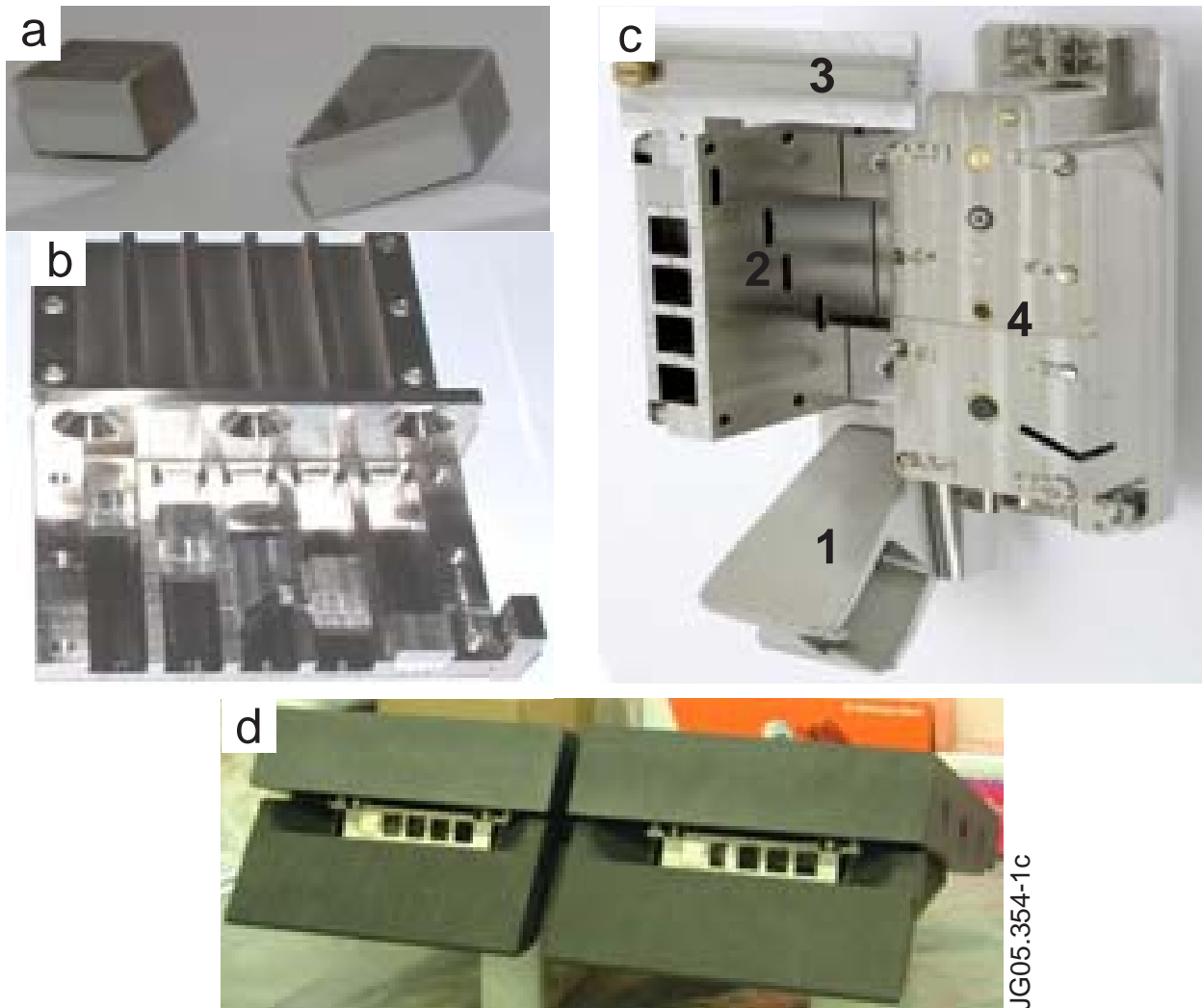

Figure 1: Components for the FMT and TRS at JET: (a) flat front and angled molybdenum mirrors; (b) open cassette with mirrors; (c) bracket assembly for installation on the main chamber wall: 1. wall bracket; 2. cassette with mirrors; 3. magnetic shutter; 4. rotatable deposition monitor; (d) cassettes installed in the divertor base.

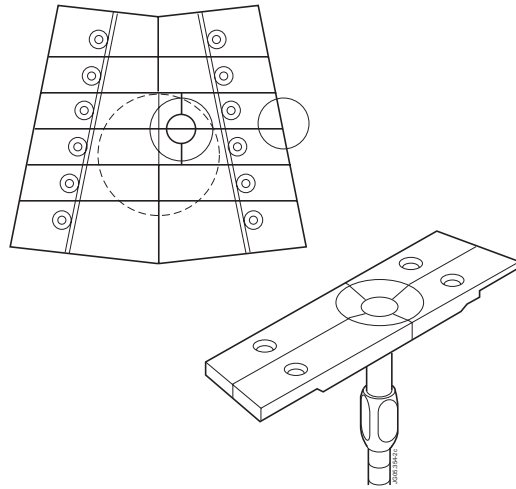

Figure 2: Schematic drawings showing the installation of the sample manipulator in the TCV vessel floor.

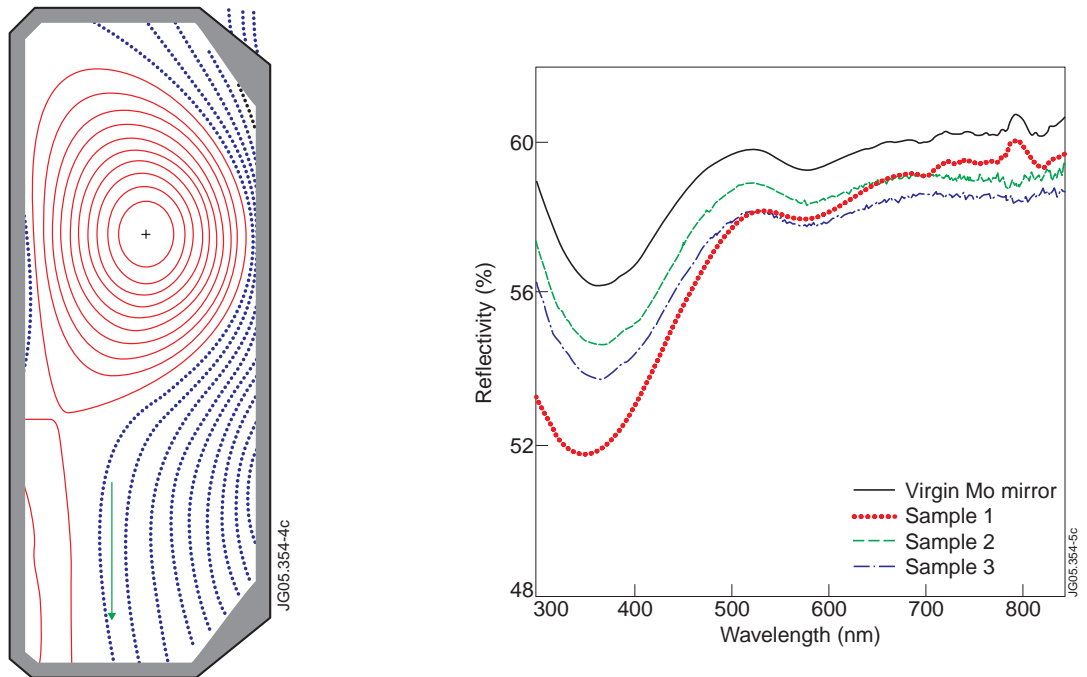

Figure 3: (a) Magnetic equilibrium of the TCV standard single null diverted discharge. The red arrow indicates the mirror location; (b) Reflectivity of the mirrors before and after experiment.

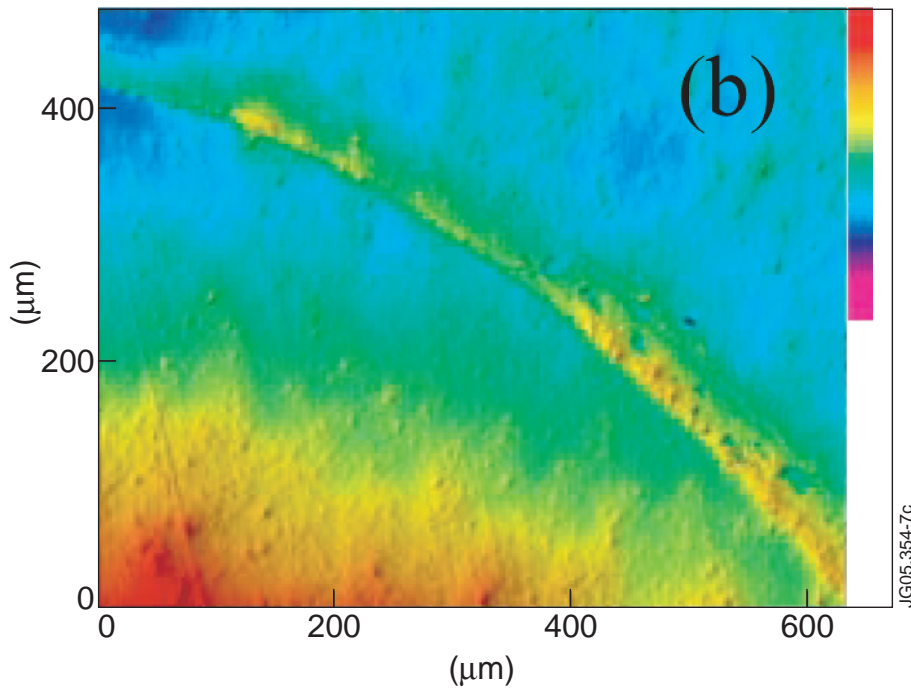
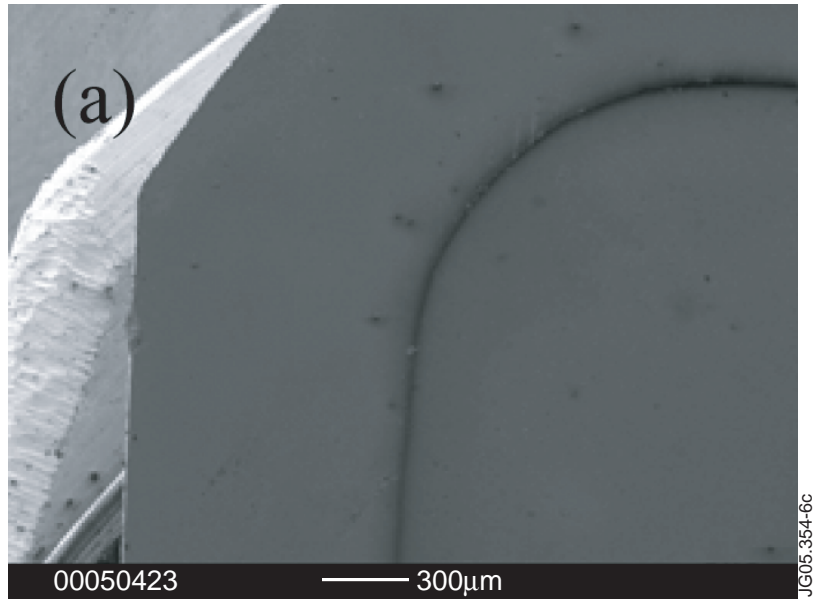

Figure 4: (a) SEM picture of the accumulation of carbon found on sample 2 at the border between exposed and non-exposed areas; (b) interferometry measurement of the same area of sample.