EFDA–JET–CP(02)04-03

D. Ciric, T.T.C. Jones, D.C. Edwards, D. Martin, A.J. Bickley, D.P.D. Brown,
S.J. Cox, A.J. Dines, J.A. Dobbing, J.J. Milnes, S.R. Shaw, D. Stork, E. Surrey,
M.J. Watson, D. Young, I.D. Young, P. Bayetti, J. Doncel
and JET EFDA Contributors

Upgrade of the JET Neutral Beam Heating System

Upgrade of the JET Neutral Beam Heating System

D. Ciric, T.T.C. Jones, D.C. Edwards, D. Martin, A.J. Bickley, D.P.D. Brown, S.J. Cox, A.J. Dines, J.A. Dobbing, J.J. Milnes, S.R. Shaw, D. Stork, E. Surrey, M.J. Watson, D. Young, I.D. Young, P. Bayetti¹, J. Doncel¹
and JET EFDA Contributors*

EURATOM/UKAEA Fusion Association, Culham Science Centre, Abingdon, OX14 3DB, UK

¹*EFDA - JET Close Support Unit, Culham Science Centre, Abingdon, OX14 3DB, UK*

** See annex of J. Pamela et al, "Overview of Recent JET Results and Future Perspectives", Fusion Energy 2000 (Proc. 18th Int. Conf. Sorrento, 2000), IAEA, Vienna (2001).*

Preprint of Paper to be submitted for publication in Proceedings of the
19th IEEE/NPSS Symposium on Fusion Engineering
(Atlantic City, New Jersey, USA 22-25 January 2002)

“This document is intended for publication in the open literature. It is made available on the understanding that it may not be further circulated and extracts or references may not be published prior to publication of the original when applicable, or without the consent of the Publications Officer, EFDA, Culham Science Centre, Abingdon, Oxon, OX14 3DB, UK.”

“Enquiries about Copyright and reproduction should be addressed to the Publications Officer, EFDA, Culham Science Centre, Abingdon, Oxon, OX14 3DB, UK.”

ABSTRACT.

The programme of the JET Octant 8 Neutral Injector Box (NIB) upgrade is the first, and to date the largest, modification of the JET machine approved within the current EFDA-JET framework. When completed in autumn 2002, this programme will result in the total injected deuterium neutral beam power of ~28MW, compared to the present maximum level of ~20.5MW. This paper gives an overview of various engineering activities and experimental trials carried out in support of this ongoing upgrade programme.

1. INTRODUCTION

Neutral beam heating system of the JET tokamak consists of two Neutral Injector Boxes (NIBs) equipped with up to eight Positive Ion Neutral Injectors (PINIs) each [1]. Until recently, the maximum total deuterium neutral beam power from two injectors was 20.5MW, with reliable high power operation achievable at 18-19MW level. This neutral beam power is generated using 8 high current tetrode PINIs operating at 80 kV/54 A (Octant 4 NIB) and delivering ~13 MW, and 8 triode PINIs (Octant 8 NIB) operating at 140 kV/30 A and delivering ~7.5 MW to the JET plasma. Both injectors can be operated using H₂, D₂, T₂, ³He or ⁴He gas.

The increase in the JET neutral beam heating power is required for various tokamak physics studies, e.g. ELMy H-mode scaling for ITER and internal transport barrier studies in optimised shear plasmas. In addition, increase in the installed power will improve reliability of the JET neutral beam heating system at high power level (≥ 20 MW).

Analysis of various means to increase neutral beam power to JET showed that the largest possible cost effective gain would come from the additional High Voltage Power Supplies (HVPS) for Octant 8 NIB, i.e. from the increase in deuterium beam current from 30 to 60A.

The decision to carry out Octant 8 NIB upgrade was made in 1999 with planned completion of the programme in October 2002. This rather large and complex project includes a variety of engineering tasks, physics studies and experimental trials:

- Procurement of the additional HVPS units to give high current capability to the Octant 8 PINIs,
- Design and procurement of the control system for the new HV power supplies,
- Re-gapping of the Octant 8 PINIs and purchase of new extraction grids,
- Re-design and construction of an upgraded Box (exit) Scraper of the Octant 8 NIB to accommodate higher power loading,
- Testing of several PINI prototypes and conditioning and characterisation of 10 upgraded high current triode PINIs, and
- Re-assessment of present neutral beam operating limits (in particular those related to duct re-ionisation and beam shine-through).

Additional engineering tasks include re-configuration of the existing HV power supplies, modification of the HV (36kV) distribution, civil works to house new power supplies, modifications to safety interlock system, control and instrumentation hardware and software.

2. OVERVIEW OF THE PROJECT

2.1. CHOICE OF BEAM ENERGY

The use of the existing HV power supplies implies the limit on the beam current of 60 A. At fixed beam current, neutral beam power is practically constant in the acceleration voltage range of interest (120-140kV). This means that the choice of maximum beam voltage is determined by other factors: power supply configuration and/or cost and power loading on the beam intercepting components, in particular on full energy residual ion dumps. Analysis of these factors led to the choice of 130 kV and 60 A as maximum beam voltage and current, respectively.

2.2 POWER SUPPLIES MODIFICATION

Eight existing 80 kV/60 A power supply units [2] are combined into four groups of two units to power four upgraded PINIs. Two new HVPS units, each delivering 130A at 130kV, are being procured, and will be used to power the remaining four PINIs on Octant 8 NIB (Fig.1).

New HVPS units are based on semiconductor technology. Each of the two units consists of 120 high frequency (2.778kHz) Insulated Gate Bipolar Transistor (IGBT) inverters. IGBT inverters are fed from the bulk DC power supply (650V/28.8kA) and provide both fast switching of 120 series-connected isolation transformers and output rectifiers on the primary (low voltage) side and HV regulation. Some of the features of the new HVPS units are:

- Pulse duration of
- 20s with maximum 255 re-applications,
- Output voltage reproducibility and stability of ± 1 %,
- Controlled linear ramp duration at turn-on 150 μ s,
- HV output decay to zero voltage after PINI breakdown within 50 μ s. PINI

2.3. ACCELERATOR MODIFICATION

The accelerator structure of the upgraded PINIs was produced by relatively simple modification of the JET 140kV/30 A PINI triode accelerator (Fig.2):

- Gap between plasma grid (G1) and deceleration grid (G3) was reduced to adjust the optimum deuterium beam current of ~60A at 130kV acceleration,
- Plasma grid aperture offset was reduced to 63% of the JET 140kV/30A triode accelerator offset in order to maintain horizontal and vertical focal lengths of 10 and 14 metres, respectively.

Electrode gap and aperture offset were determined using Kobra3-INP three-dimensional beam simulation code [3] and verified experimentally by testing several PINIs with various gaps and Since only single grid replacement is required, this modification involves minimum risk and is, at the same time, a cost-effective solution.

2.4. PINI ASSEMBLY PROCEDURE

A new PINI accelerator assembly procedure [4] was developed to minimise the misalignment of the accelerator grids, which can lead to beam transmission losses and increased power loading of

beam intercepting components. PINI accelerators are assembled with the aid of a robotic arm applied to measure accurately ($\pm 25\mu\text{m}$) three-dimensional coordinates of characteristic accelerator apertures for each PINI grid. Measured data are then used to construct a three-dimensional map of the entire accelerator, and to predict the properties of the beam prior to actual PINI testing at the Neutral Beam Test Bed. The new assembly procedure greatly improved the alignment of JET PINI accelerators, which is of particular importance for upgraded triode PINIs due to their high power output.

2.5. PINI CONDITIONING AND CHARACTERISATION

Several upgraded triode PINIs have been conditioned to full power and characterised at JET Neutral Beam Test Bed [5]. The aim of these tests was to

- a) establish the conditioning procedure;
- b) measure various beam parameters (divergence, optimum perveance, focal lengths, beam profiles, etc.); and
- c) Verify whether the increased power loading can be sustained by the ion source, accelerator and various beamline components.

Tests at the JET Neutral Beam Test Bed revealed that the total beam on time required to condition an upgraded triode PINI to full power is $\sim 5000\text{s}$, which is equivalent to ~ 1500 beam pulses or ~ 120 hours of Test Bed operation. Fig.3 illustrates the conditioning history of one upgraded triode PINI.

Optimum deuterium beam perveance is $\sim 1.23 \times 10^{-6} \text{ A/V}^{3/2}$, corresponding to $\sim 57\text{A}$ of beam current at 130kV extraction.

Maximum deuterium beam current of 59.1A was measured at 135 kV extraction, corresponding to 8MW of total extracted beam power, which is probably the highest power output ever produced by a single positive ion injector. This record power was achieved at total deuterium gas flow (source+neutraliser) of 26 mbar l/s and set arc current of 1270 A. Maximum measured deuterium current using tritium compatible gas feed in the inter-grid region [6] was 50A and was achieved at arc current of 1400A and gas flow of 28mbar l/s. This beam current allows operation of tritium beams at optimum perveance at extraction voltages up to 136kV.

Power loading of the ion source body, accelerator grids and the neutraliser, although higher than in previous JET PINI designs, is still well within the components' design limits.

Upgraded triode PINIs showed exceptionally high reliability during conditioning phase on the Neutral Beam Test Bed. At the end of each PINI conditioning, a reliability run was carried out by performing a sequence of 100 beam pulses at 95% of the maximum beam voltage. High reliability is demonstrated by exceptionally high ratio of total achieved to set pulse duration, which exceeded 97% for all PINIs conditioned so far.

2.6. BEAMLINER COMPONENTS

Due to considerably higher beam power, most of the beamline intercepting components will be exposed to higher power load. Detailed analysis of power distribution in the Octant 8 NIB was carried out to assess whether existing and newly installed beamline components can sustain increased

beam power. Full Energy Ion Dumps (FEID) will be the most heavily loaded components. The power density limit of the FEID hypervapotron elements is 10 MW/m^2 . Thermal fatigue test of hypervapotron elements carried out at JAERI electron beam facility [7] and engineering analysis predict additional lifetime of $>10^4$ cycles at even higher power level of 13 MW/m^2 .

Power loading of the Fractional Energy Ion Dumps and Inertial Calorimeter Back Panels will remain within existing design limits.

Inertial Calorimeters, used during commissioning phase of the neutral beam injectors, will be exposed to higher power density beams. This will restrict beam pulse duration during deuterium beam commissioning to 1 s below 90kV and 0.4 above 90kV.

The only beamline component, which was re-designed and installed in the 2001 JET shutdown, is the Box Scraper. This component limits the horizontal size of the beam at the exit of the NIB and protects downstream components. The modification of the Box Scraper geometry is illustrated in Fig.4: one triple cooling channel hypervapotron element is replaced with two double channel hypervapotrons. In addition, the geometry of the hypervapotron was modified by reducing the front wall thickness from 6 to 4mm, hypervapotron fin height from 8 to 4mm, and water channel height from 10 to 8mm.

The new Box Scraper has improved power handling capabilities, while accommodating limitations of the existing cooling water system (flow, pressure drop and temperature rise):

- a) Maximum peak power density normal to the element is increased from 10 to 13 MW/m^2 ,
- b) Total power loading capability of one quadrant (two PINIs) is increased from 0.5 to 1MW.

These operating limits were confirmed by testing one quadrant of the new Box Scraper at the Neutral Beam Test Bed.

The Box Scraper of the Octant 4 NIB was modified in the same manner. Maximum power of the Octant 4 injector was limited by power loading of the Box Scraper and PINIs were rarely operated at maximum beam voltage of 80kV. The new Octant 4 Box Scraper will allow operation of all PINIs at full power.

2.7 DUCT RE-IONISATION AND SHINE-THROUGH OPERATING LIMITS

Neutral beam power from a single NIB is injected into the JET plasma through a 0.23m wide and 0.93m high Beam Duct. The beam pulse duration is limited by the maximum surface temperature of the copper duct liners, which are exposed to the heat flux originating from direct beam interception and re-ionised beam particles. At present, beam pulse is terminated if a) duct liner surface temperature exceeds 500°C or b) the pressure in the duct exceeds 3.1×10^{-5} mbar.

An attempt was made to simulate duct behaviour for the upgraded Octant 8 Injector [8]. The simulation predicts that the 500°C limit will be reached within 6s, which means that Beam Duct may become the major limiting component with respect to the Octant 8 NIB beam pulse length.

The shine-through power and its effect on in-vessel component has also been re-assessed [8]:

- a) Power density beam profiles from the upgraded PINIs were calculated at various points of

- interest (inner and outer walls of the JET vessel).
- b) The shine-through fraction of each beam was derived using PENCIL power deposition code assuming minimum prescribed JET plasma density.
 - c) Attenuated power density profiles were transferred to the Drawing Office CATIA system and overlaid on various in-vessel components (Fig. 5).

Several potential problems have been identified and will be dealt with by the modification of the real-time protection system [8].

2.8. ESTIMATED POWER TO JET

The increase in neutral beam power from a single PINI, which will be achieved by the present upgrade programme, is illustrated on Fig.6. By changing the nominal deuterium operational parameters from 140 kV/30A to 130 kV/60A injected neutral beam power will be increased from 0.95MW per PINI to ~1.9MW. When operated in tritium at 130 kV extraction voltage, the injected power per PINI will be increased to 2.4 MW. Four of the Octant 8 PINIs, which are operated using old power supplies, can run at higher extraction voltage and the maximum tritium neutral beam power for these PINIs will be ~2.6MW when operated at 136 kV/50A.

3. CURRENT STATUS OF THE PROJECT

The upgrade of the JET neutral beam heating system started in 1999 and is well under way. The present status of the project is outlined below:

- new Box Scrapers were installed during the JET 2001 Shutdown;
- PINI accelerator grids (10 sets of two halves) have been delivered to JET;
- five PINIs were conditioned during last year and installed in November 2001 - four were installed on Octant 8 NIB and one was installed on Octant 4 NIB (to enhance the performance of the Motional Stark Effect diagnostic);
- additional five PINIs (one spare) will be conditioned in the first half of 2002 and four will be installed on Octant 8 NIB in May 2002;
- re-configuration of the old HVPS, modifications to the HV distribution, and changes to computer interface and operating software were completed during JET 2001 Shutdown;
- new power supplies are being manufactured (JEMA, San Sebastian, Spain) and will be delivered in May 2002, together with the control system for the new HVPS, which is being manufactured in the UK;
- commissioning of the new HV power supplies and control system should be completed by October 2002.

During the EFDA-JET C5 experimental campaign, which starts in March 2002, total neutral beam power will remain unchanged: 20.5MW (deuterium). After the completion of the neutral beam upgrade, total neutral beam power will be raised to >28MW (C7 experimental campaign at the end of 2002). When operating Octant 4 with deuterium beams and Octant 8 with tritium beams the

maximum neutral beam power to JET will be $13 + 20 = 33$ MW, but the pulse length at this level will probably be restricted [8].

ACKNOWLEDGEMENTS

This work has been conducted under the European Fusion Development Agreement (EFDA) and is partly funded by Euratom and the United Kingdom Department of Trade and Industry.

REFERENCES

- [1]. G. Duesing et al., "Neutral beam injection system", Fusion Technology, vol. 11, pp. 163-202, 1987.
- [2]. R. Claesen and P.L. Mondino, "Neutral beam injection and radio frequency power supplies" Fusion Technology, vol. 11, pp.141-162, 1987.
- [3]. P. Spädtkke, KOBRA3-INP Version 3.35, INP, Wiesbaden, Germany, 1996.
- [4]. D. Ciric, J. Milnes and E. Surrey, "Influence of accelerator grid misalignment on multi-aperture particle beam properties", these Proceedings.
- [5]. E. Surrey, D. Ciric, D. Godden and B. Crowley, "Properties of the JET 130kV/60A positive ion neutral injector", these Proceedings.
- [6]. T.T.C. Jones et al., "Tritium operation of the JET neutral beam systems", Fusion Eng. & Design, vol. 47, pp.205-232, 1999.
- [7]. D. Ciric et al., "Design issues and fatigue lifetime of hypervapotron elements of the JET neutral beam injectors", Proceedings of the 18 th IEEE/NPSS Symposium on Fusion Engineering, Albuquerque, N.M., USA, October 25-29, 1999, pp. 407-410.
- [8]. S.J. Cox, A.J. Bickley, T.T.C. Jones and J.J. Milnes, "Operating limits of the upgraded JET neutral beam injector from duct re-ionisation and beam shine-through", these Proceedings.

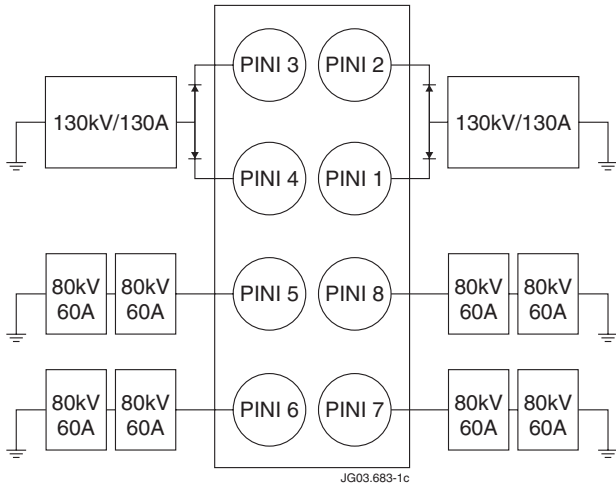

Figure 1. Configuration of the JET Octant 8 Neutral Injector Box HVPS system.

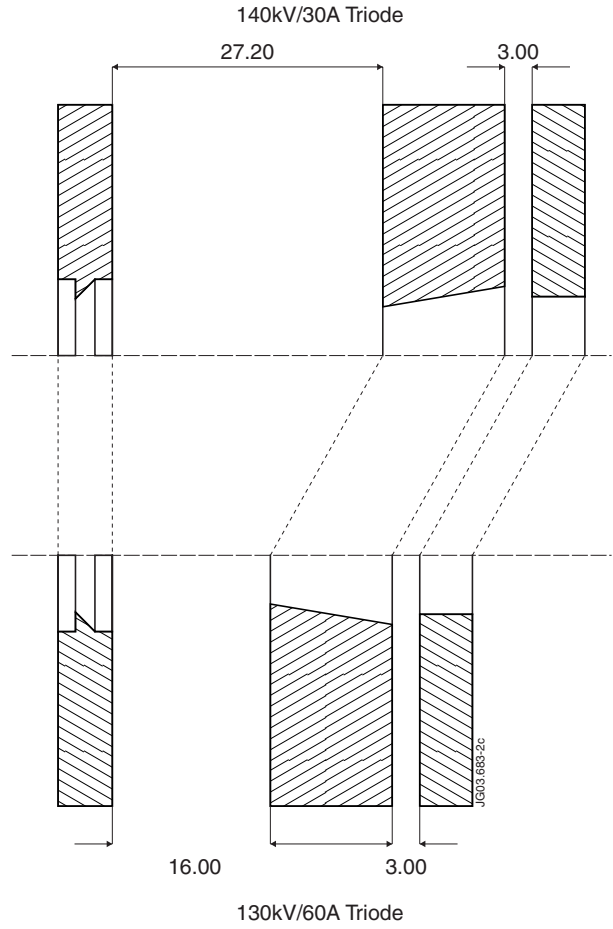

Figure 2. Modification of the JET triode PINI accelerator geometry.

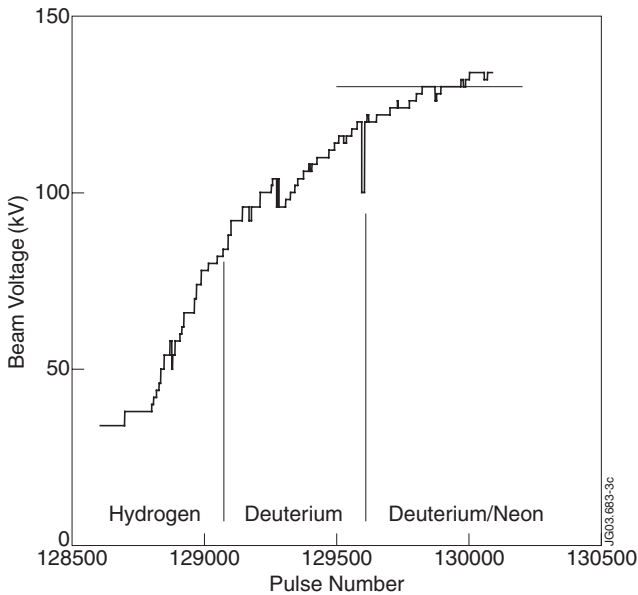

Figure 3: Conditioning history of upgraded triode PINI. Deuterium/neon mix is used to allow conditioning above maximum voltage while maintaining beam current below the power supply limit of 60A.

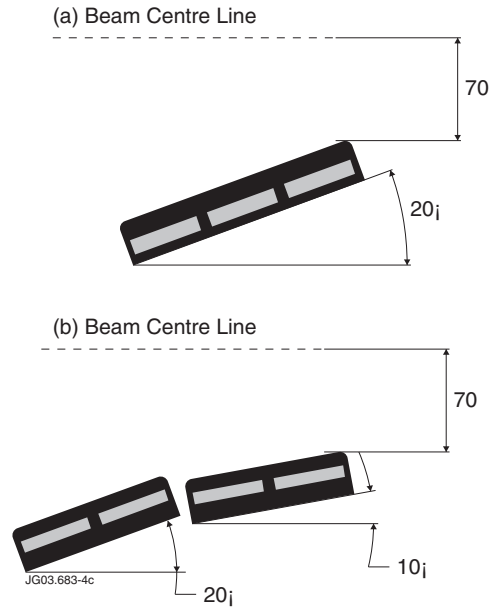

Figure 4: Modification of the Box Scraper geometry: (a) old configuration and (b) new configuration.

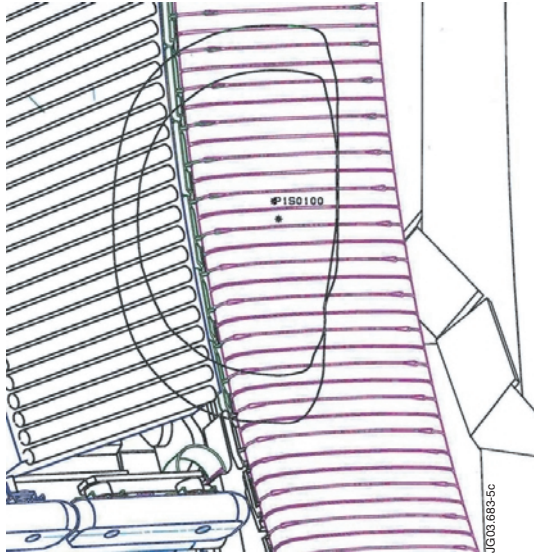

Figure 5. Shine-through power density contours (1 MW/m^2 and 0.5 MW/m^2) under conditions of minimum beam attenuation (i.e. minimum plasma density) overlaid on the outer wall of the JET machine (ICRH antenna.).

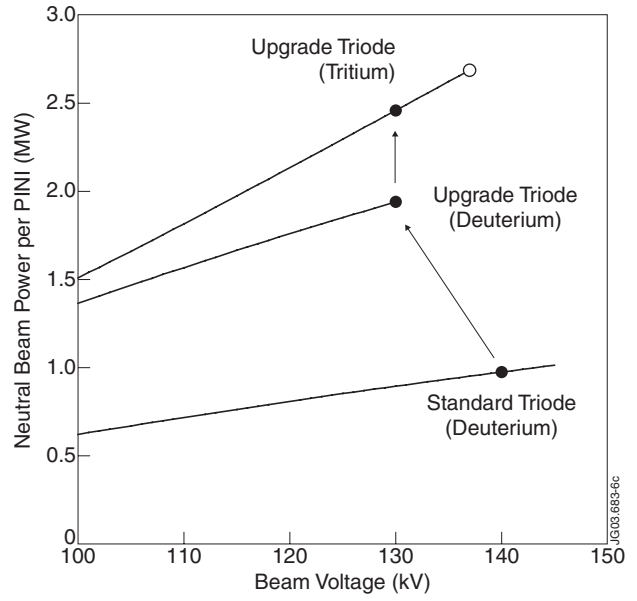

Figure 6. Estimated neutral beam power injected to JET plasma from a single Octant 8 PINI.